

The background of the cover is a painting depicting a telegraph station. A dense, intricate web of black wires crisscrosses the scene, creating a complex geometric pattern. In the foreground, a brass instrument, possibly a telegraph key or a similar device, is visible, featuring a circular lens and a small, ornate finial. The overall color palette is muted, with earthy tones and a sense of historical atmosphere.

# VICTORIANS DECODED

## ART AND TELEGRAPHY

EDITED BY  
CAROLINE ARSCOTT  
CLARE PETTIT

## VICTORIANS DECODED: ART AND TELEGRAPHY

Edited by  
Caroline Arscott and Clare Pettitt

With contributions by:  
Caroline Arscott  
Anne Chapman  
Natalie Hume  
Mark Miodownik  
Cassie Newland  
Clare Pettitt  
Rae Stather

Exhibition Catalogue for the exhibition *Victorians Decoded: Art and Telegraphy* held at The Guildhall Art Gallery, London from 20th September 2016 to 22nd January 2017.

Published by The Courtauld Institute of Art  
Somerset House, Strand, London WC2R 0RN and King's College, London, Strand, London WC2R 2LS.  
© 2016, The Courtauld Institute of Art, London and King's College, London  
ISBN: 987-1-907485-053

All sections of this catalogue are available for free download at the project website for *Scrambled Messages: The Telegraphic Imaginary 1857-1900*  
<http://www.scrambledmessages.ac.uk/>  
This website is hosted by King's College, London

Every effort has been made to contact the copyright holders of images reproduced in this publication.  
This work is licensed under a [Creative Commons Attribution-NonCommercial-NoDerivs 3.0 Unported License](#).  
All rights reserved. No part of this publication may be reproduced, stored in a retrieval system, or transmitted in any way or form or by any means, electronic, mechanical, photocopying, recording or otherwise without the prior permission in writing from the publisher.

Designed by Olivia Alice Clemence

## BACK AND FRONT COVER:

James Tissot, *The Last Evening*, 1873 (details), The Guildhall Art Gallery, Corporation of London.



# FOREWORD

Caroline Arscott and Clare Pettitt

## INTRODUCTORY

*Victorians Decoded* is a vehicle for thinking about science and culture. This research-led exhibition has grown out of a four-year interdisciplinary project, *Scrambled Messages: The Telegraphic Imaginary 1857-1900*.

*Victorians Decoded: Art and Telegraphy* puts pictures on display that have not been seen since the nineteenth century and brings scientific papers and instruments out of the archive into the space of the art gallery. The exhibition mixes academic painting with outlying examples to create an unusually comprehensive picture of high art and visual culture in the mid to late nineteenth century. We deliberately turned away from canonical reputation or modernist characteristics as the index for our show. Following ‘cable themes’ (rather than traditional art-historical trajectories and genealogies) reveals commonalities between works which might previously have been considered to be opposite in tendency, for example Walter Greaves’s avant-gardist *The Pool of London* (1863-1869) and Edwin Landseer’s academic work, *Man Proposes, God Disposes* (1864). These two works are bracketed together to produce a powerful argument concerning passage and impedance. This catalogue has been written by researchers working in a wide variety of different fields and we have streamed and entwined our methodologies through the entries. New lines of argument and startling new interpretations of Victorian works have emerged. The entire sequence of catalogue entries constitutes an intervention in cultural history and the history of science, offering innovative and exciting ways to think about Victorian painting and science.

## SIGNALS

*Scrambled Messages* proposed a reconceptualisation of the way that scientific and technical history can be brought into meaningful contact with the history of art and literary theory. Our interdisciplinary research group includes literary scholars, art historians, historians of science, archaeologists, physicists and engineers. Bringing scientific and artistic objects into conversation with each other can challenge and change accepted notions of the aesthetic or the functional. By taking the idea of the telegraph as the primary object of our investigation we were able to break free of empirical scientific explanation on one hand, and from the non-specificities of literary ‘thing theory’ on the other. We were able to track the mobility of objects and the ideas instantiated in them in ways that avoid the cybernetic bias of network theory and the anthropocentric bias of traditional theories of art or literary criticism. The result is the generation of a materialist paradigm of nineteenth-century realism that pivots on the notions of mediation that fascinated the Victorians themselves.

## DISTANCE

The thematic emphasis on distance has made possible an engagement with Victorian landscape painting, hitherto relatively neglected by cultural historians. Distance was a challenge for the cable engineers and was central among the marvels rehearsed by Victorian enthusiasts for telegraphy. This exhibition shows that in the Victorian period the spaces of landscape, stretches of coast, ocean depths, river scenery, and grassy or wooded zones were reimagined. Spaces that might be unpeopled (or sparsely occupied) and minimal in feature were conceived of as theatres for action. The action that unfolded was nothing less than the play of industrial and cosmic forces. In this age of electrical signalling it was possible to stake claims for the industrial as the channel for the cosmic. Rather than staging the deeds of naval or mythological heroes, the landscapes of late Victorian art staged the agitation of particles. Energy coursed through substances; light, heat, magnetism and electricity could figure as well as other forces. In a dynamic universe nature was not empty. This exhibition has identified the phenomenon of full emptiness or empty fullness in Victorian landscape. Standard responses to grandeur of scenery and the activation of the sublime were no longer the primary means of engaging with landscape. Poetic parallels, for instance the insistent drone-like rhythms of Swinburne's verse, have informed our analysis of late Pre-Raphaelite, Aestheticist and Academic landscape. Project research on distance has made possible a re-examination of the role of minute observation when nature is conceived of as empty plenitude as in John Brett's coastal scene. It alerts us to repetition, multiplication and ornament in marine painting, as in the work of Henry Moore and William Ayerst Ingram. It enables an assessment of the 'poetic' as a term of appreciation in late Victorian art criticism and equips us to interpret the complex orchestration of mood by artists such as James Clarke Hook and Gustave de Breanski. Theoretical physics and mathematics were pushed forward by the requirements of telegraphy, and the urgency of commercial, political and military applications. An awareness of this has encouraged us to develop ideological readings of the works in the exhibition. *Victorians Decoded* registers the exploration of nature and experiments with form in the works displayed. Additionally we posit their importance for the social and political fabric of Victorian society.

## TRANSMISSION

In the 'Transmission' section of the exhibition the emphasis shifts from scenery to figure painting. Allegorical pictures and genre scenes are brought together to demonstrate Victorian art's envisaging of systems of transmission, putting the linkage of (human) units at the heart of the composition. Within the exhibition historic instruments for sending

messages are brought into close proximity to the paintings. Fingerboards and buttons on instruments are evocative of the somatic dimension of message sending and yield the opportunity to investigate ways in which the social agent, or the body itself, can stand as a metaphor for the substance of the cable. A comparison of human nervous systems with the wires of the telegraph was common and the idea of electricity running through the body was not strange to the Victorians. The issue that was important regarding the nervous system was the relationship between voluntary and involuntary action. For Evelyn De Morgan the spirit message that passes through the nerves is ambivalently placed between a willed contact and a message that flows automatically. Transmission could be a communal project, as Hook saw it, or it can be an unwilled and unwanted process.

In telegraphic transmission the clarity of signaling depended on maintaining a rhythm and tempo that kept elements separate. Instruments were devised to register extremely small variations. Frederic Leighton's *The Music Lesson* (1877) is included in the exhibition as a picture that meditates on minimal difference and the borderline between maintenance of identity and the merging of identity. It suggests a teetering between the binary and hybridized. It is an eloquent example of art that thematises the move from analogue to the compression of the digital in the way that it packs information into pattern and ornament.

## CODING

In this section, we see artists responding to ideas of coding visually, thinking through repetitive motifs and testing the limits of communication and category formation.

When the electric telegraph first appeared in the 1830s, a particular and specific series of ideas about codes, coding and decoding was already circulating in the nineteenth-century European imagination. Jean-Francois Champollion had deciphered Egyptian Hieroglyphics in the 1820s and British East India Company army officer, Henry Rawlinson had successfully deciphered Cuneiform and started to publish his translations in 1847. In the mid nineteenth century, the long-running debate over the authorship of Shakespeare's plays rested on efforts to decode the texts. Francis Bacon, who was possibly the inventor of binary code, was believed by many to be the 'true' Shakespeare for some time. So there is a wider nineteenth-century context for codes that must also include the work of Darwin and Galton, and the idea of transmissible inherited information that was developing alongside the emerging science of structural linguistics.

*Victorians Decoded* charts the crucial move from analogue to digital inaugurated by electric

telegraph technology. This has resulted in a focus on the idea of the pattern and structure of binary code, and the kinds of transformations that take place when sending signals. Complex information had to be packed into small enough units to enable it to travel vast distances. The exhibition shows that in the context of coding and decoding, loss was endemic. The physicality of spoken language could not be conveyed and messages could be mangled in transmission through error or technical incapacity. Pictures shot through with melancholy evidence this loss: non-communication and abandoned options are featured in works by Solomon, Tissot and Watts.

## RESISTANCE

In terms of the theoretical framework of the exhibition it was important to us to include the category of resistance which references the phenomenon of electrical impedance which preoccupied the telegraph engineers. The project has deliberately avoided an account of technological innovation as trouble-free and of modern communications systems as producing ever more transparent connectivity in an information world. Certain strands of Post-Modern theory have had a tendency to view history in these terms, recapitulating the triumphalist claims of Victorian journalists who were ready to assert that the telegraph had abolished space and time. Our researchers are historians who view culture in terms of evolving possibilities and shifting material constraints, and investigators of media and materials acutely aware that 'stuff matters', whether words, paint or the atomic structure of copper. As we consider representation we acknowledge that non-transparency goes beyond medium to form and beyond form to the social conventions governing language and social interaction, with historical mutability at every level. This exhibition celebrates the achievement of establishing transatlantic telegraphic communication 150 years after the laying of the robust cable of 1866 and makes forceful claims for the impact of the new communications technology on the cultural imagination. But it mounts the celebration in a non-triumphalist manner, recognizing that time and space were not abolished, that attention was directed more than ever to the non conductors; insulation and impedance were as important to the cultural imagination as conductivity.

## PROJECT RESOURCES

This catalogue has been written by the entire team of the Arts and Humanities Research Council funded four-year project, *Scrambled Messages: The Telegraphic Imaginary 1857-1900*. The team consists of Caroline Arscott, Professor of Art History at The Courtauld Institute of Art, author of *William Morris and Edward Burne-Jones: Interlacings*

(2008) and Chief Curator of this exhibition; Clare Pettitt, Professor of English Literature at King's College London, author of *'Dr. Livingstone, I Presume': Missionaries, Journalists, Explorers and Empire* (2007) and Co-Curator of this exhibition; Professor Mark Miodownik, Materials Scientist and Director of the Institute of Making at University College London and the author of *Stuff Matters: The Strange Stories of the Marvellous Materials that Shape Our Man-Made World* (2013); Cassie Newland, Archaeologist and Post-Doctoral Researcher for the project at King's College London, responsible for the selection of scientific items for the exhibition; Anne Chapman, Literary Scholar, PhD student on the project at King's College London, responsible for the development of teaching materials relating to the project and schools outreach; Natalie Hume, Art Historian and PhD student on the project at The Courtauld Institute of Art, responsible for detailed research on Victorian landscape painting for the exhibition. Additionally Sonia Solicari, Vicky Carroll and Katty Pearce, the curatorial team at the Guildhall Art Gallery, have lent support and valuable advice at every stage of the project. The display of materials in the exhibition gives a small glimpse of the extensive cataloguing, interpretation and conservation undertaken on Wheatstone materials at King's College London as part of the project. Members of the Department of Digital Humanities at King's College London also participate in the project. Our exhibition extends our efforts to encourage free public access to this previously unavailable material. The public-facing nature of the exhibition is paralleled by project-developed schools resources, downloadable from our website.

## LEGACY OF THE SHOW

We hope that the legacy of this exhibition as a major outcome of our research project will be its impact on historical studies. *Victorians Decoded* shows the benefits of basing research around metaphor. The cable became a metaphor for the Victorians as soon as it was laid. The investigation of metaphor offers a way of exploring historical phenomena from multiple disciplinary viewpoints. Approaching historical conjunctures through freshly emergent metaphors is one way to write history.

# ACKNOWLEDGEMENTS

For underpinning support for the Scrambled Messages project and its outputs: the Arts and Humanities Research Council.

For ongoing advice for the Scrambled Messages project: Advisory Board members Graeme Gooday and Roland Wenzlhuemer.

For hosting and realising the exhibition at The Guildhall Art Gallery: the Corporation of London; We are extremely grateful to the Guildhall Art Gallery curatorial team especially Sonia Solicari; Vicky Carroll and Katty Pearce. For exhibition installation and building Tom Scase and Paul Collins, visualisation Domenico Laneve; object-files research Fiona Ratcliffe.

For design work for the exhibition; Matthew Hodges at Matt Hodges Design Limited.

For generously lending a large body of material for the exhibition: King's College London; we are particularly grateful to Catherine Sambrook, Frances Pattman and Brandon High from KCL Foyle Special Collections Library and Patricia Methven and Lianne Smith from KCL Archives.

For loans: Bill Burns, De Morgan Foundation, Royal Academy, London; Royal Borough of Kensington and Chelsea (Leighton House); Royal Holloway, University of London; The National Archives.

For support for Alexandra Bridarolli's *The Great Grammatizor: Marvellous Messaging Machine*: The Institute of Making, University College London, particularly Sarah Wilkes.

For extreme dedication and efficiency in assisting with the making of the catalogue: Rai Stather.

For design and technical expertise in the making of the catalogue: Olivia Clemence.

For website development and technical advice: Department of Digital Humanities, King's College London.

For technical advice and catalogue template: the Sackler Research Forum, The Courtauld Institute of Art, especially Alixe Bovey; Fern Insh, James Cameron, Maria Mileeva and original template designer Jack Hartnell.

We are grateful for financial support for the exhibition and the catalogue from Arts and Humanities Research Council; Department of English, King's College London; The Courtauld Institute of Art.

For assistance with publicity Leanne O'Boyle, David Wilson, Emily Butcher and Michael Sherry.

For creative suggestions Tilly Blyth, Mischa Dohler, Roo Gunzi, Pat Hardy, Ali Hossaini and many other friends and colleagues.

## A NOTE ON ABBREVIATIONS USED IN THE CATALOGUE

Royal Academy/ Royal Academician RA

Associate Royal Academician ARA

Dimensions of artworks are given as height X width

For paintings referenced in the catalogue the medium is oil on canvas, unless indicated otherwise.

Catalogue Contributors -- Caroline Arscott (CA); Anne Chapman (AC); Natalie Hume (NH); Mark Miodownik (MM); Cassie Newland (CN); Clare Pettitt (CP); Rai Stather (RS).



# CONTENTS

Foreword	3
Acknowledgements	8
<b>SECTION 1: SIGNALS</b>	
A Brief Introduction to Electricity MARK MIODOWNIK	12
Catalogue Entries for Signals Section	16
<b>SECTION 2: DISTANCE</b>	
Between the Empirical and the Abstract: Grimshaw's <i>The Thames By Moonlight with Southwark Bridge</i> NATALIE HUME	28
Profound Repetition: Hook's <i>Deep Sea Fishing</i> ANNE CHAPMAN	34
Chatterton's Compound CASSIE NEWMAN	40
Catalogue Entries for Distance Section	45
<b>SECTION 3: TRANSMISSION</b>	
Dispersed Consciousness: Evelyn De Morgan's Moonbeams <i>Dipping Into the Sea</i> CLARE PETTITT	87
Electrifying the Literal: Topham's <i>Rescued from the Plague</i> CAROLINE ARSCOTT	93
Grim Spectres: Logsdail's <i>The Ninth of November, 1888</i> CAROLINE ARSCOTT	98
Engineering and Oratorios: Poynter's <i>Israel in Egypt</i> CAROLINE ARSCOTT	107
Telegraphic Copper CASSIE NEWMAN	114

# CONTENTS

Catalogue Entries for Transmission Section	119
<b>SECTION 4: CODING</b>	
Coded Encounters: Tissot's <i>The Last Evening</i> ANNE CHAPMAN	145
Catalogue Entries for Coding Section	151
<b>SECTION 5: RESISTANCE</b>	
Franklin's Messages: Edwin Landseer's <i>Man Proposes, God Disposes</i> CLARE PETTITT	172
Resistance and Boundaries: Peter Graham's <i>Ribbed and Paled in by Rocks</i> <i>Unscalable and Roaring Waters</i> NATALIE HUME	180
Gutta-percha CASSIE NEWMAN	188
Catalogue Entries for Resistance Section	193

# SIGNALS

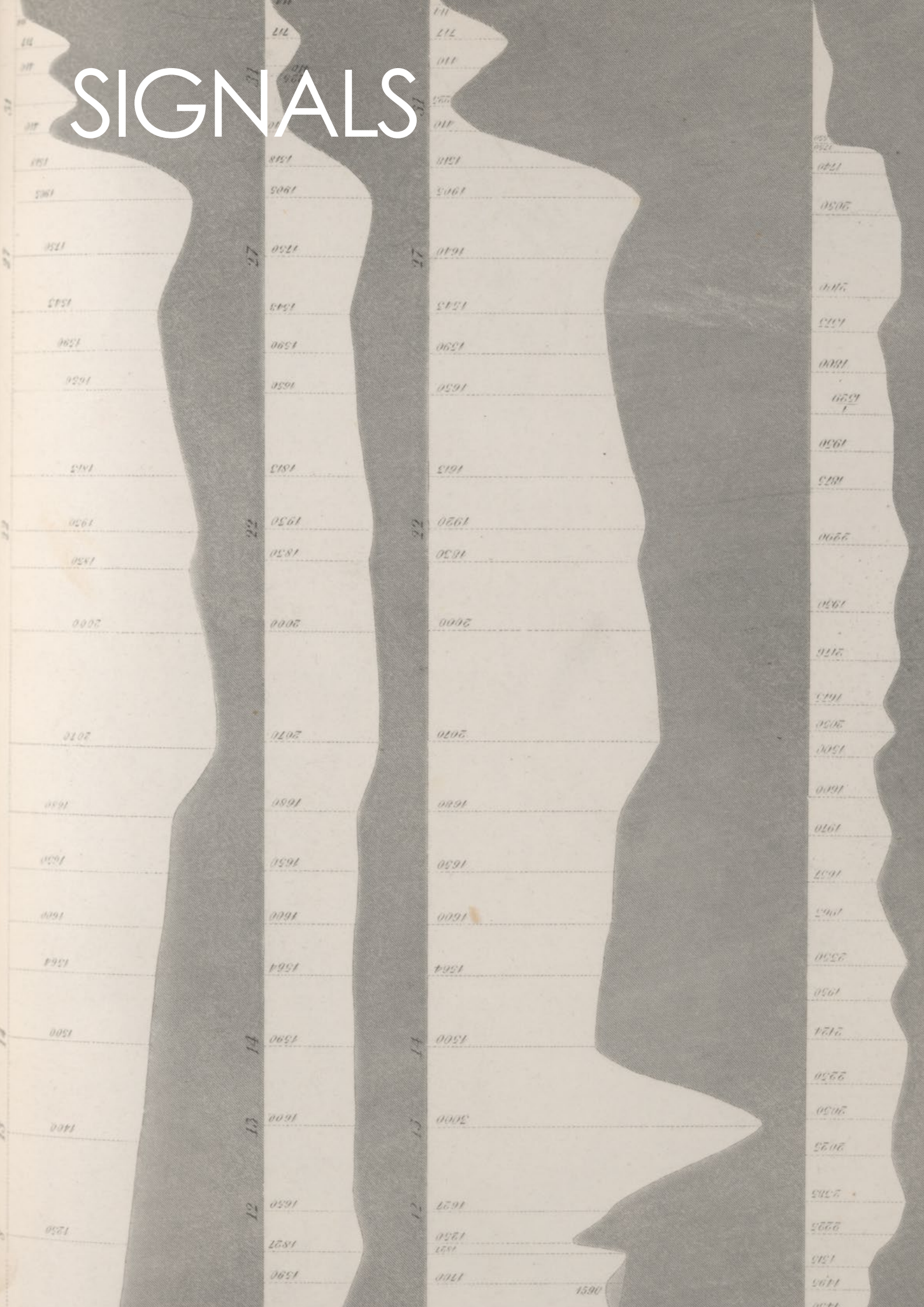

# MARK MIODOWNIK

## A BRIEF INTRODUCTION TO ELECTRICITY

This essay is intended as a primer for anyone unfamiliar with the basics of electricity, specifically: how it works, how it was employed to send messages along transatlantic telegraph cables, and its modern usage for sending information along wires such as from your phone to your headphones. This essay does not contain an historical account of the development of the understanding of electricity, electromagnetic theory as it is called, for an introduction to this a good source is *Electric Universe*.<sup>1</sup>

Every thing is made of atoms. There are 94 types of naturally occurring atoms, but they all share a common structure that comprises of a central nucleus containing positively charged particles called protons surrounded by negatively charged particles called electrons. Occasionally some of the electrons get free and start moving about. This movement of electrons is the basis of electricity. If you have ever rubbed a balloon on a woollen jumper and felt the build-up of charge you have successfully pulled electrons away from the nuclei of their atoms. Once free these electrons repel and want to get as far away from each other as possible. Hence if you hold the balloon up to your head you will feel the electrons jumping off the balloon onto your hair as they try to get away from each other. In an attempt to get further away they make your hair stand on end which is caused by the charge on each follicle repelling the others. Of course the electric charge ultimately wants to be reunited with positive charge and will flow or even jump through the air to do so. This is what happens during a thunder storm. Electric charge that has built up in cumulonimbus cloud as a result of certain climatic conditions, discharges through the air to the ground, and in doing so heats up the air to such high temperatures that it glows white hot, this is what lightning is. The sonic boom of the surrounding air rapidly expanding as it is heated, is the sound of thunder that accompanies lightning.

Storing electricity is difficult, as the balloon example shows; electrons once collected repel each other. They don't like to be compressed into a small space, and may discharge violently as in the case of thunder. The answer is to create a battery. Batteries produce electricity through chemistry by getting one type of atom to pull the electrons off another type of atom, this is called a chemical reaction. When iron rusts, the iron atoms are chemically reacting with oxygen to create iron oxide, thus creating a chemical bond between the oxygen and the iron atoms. This involves electrons moving from the iron atom to the oxygen atom. Chemical reactions like this that involve electron transfer do not require the two atoms to be physically next to each other, they can be separate and the reaction will still occur as long as there is a way that charges can travel between the atoms. This is the essence of a battery. In a battery the chemical reaction provides the energy for the electrons to flow down wires as long as the wire completes a circuit between the two materials. When a battery isn't being used, the two ends of a battery (the + and -) are not connected and cannot react so the energy remains stored. This potential energy of the electrons stored in the battery is called the voltage (Volt). In a simple disposable AA 1.5 Volt battery the chemical reaction

is between zinc and manganese dioxide. In your mobile phone it is chemical reactions based on lithium that provide the electricity. Lithium is expensive but it is hard to beat for batteries because the reversibility of the chemical reactions involved means the battery is rechargeable, as well as being lightweight and with a high energy capacity. This means that it can provide lots of electrons. The flow of electrons, is an important characteristic of electricity and is called the current. You need a big enough current to deliver enough energy to do anything useful with electricity. For instance a light needs a constant flow of electrons to be able to keep giving out light, similarly your phone needs a constant current of electrons to keep transmitting data. If you need a large current you need a big battery, which is why car batteries are so big because the forces needed to turn the engine are large. The Victorians invented many types of batteries but the one used on the Transatlantic Telegraph Cable was called the Daniell cell. It harnesses the chemical reaction between zinc and copper compounds yielding 1 Volt. As you might guess if you want more current you join Daniell cells together to make a bigger battery, which is the origin of the word (as coined by Benjamin Franklin in analogy to a battery of cannon).

Once you have a battery you can reliably control electric signals down a wire to create a telegraph. But you need to be careful what wire you use, since not all materials conduct electricity. Some materials bind electrons very tightly to their atoms through atomic bonds leaving them unable to move through the materials; rocks, ceramics, plastics, woods, textiles are all examples of materials that do this, they are called non-conductors. Metals however, are held together by a type of bonding that allows some of the electrons to be free; it is these free electrons that allow metals to conduct electricity. It comes at a cost though, called resistance, which is due to the electrons bumping into atoms as they flow. This absorbs some of the strength of an electric signal. Iron conducts quite well, copper conducts better, and silver conducts electricity best of all metals. When trying to send a pulse of electric current across the Atlantic through a wire, it is obvious that engineers needed to minimise the resistance of the cable. Hence the ideal metal to use would have been silver. However the expense of this was too great. Copper is the next best conductor and although expensive, this is what was used. These days we still use copper, the wires that take electricity from the power station to your home and into your kettle are copper for the same reason. In fact it is very pure copper because the purity matters. Metals are made of crystals and so their atoms are arranged in a very regular order. Impurities disrupt this order and cause more interference to the current of electrons, hence the desire for purity.

In the Transatlantic Cable this subtlety was not understood by everyone involved, and so the resistance of that cable was not as small as it might have been. This is one of the reasons why the electrical signal quality was poor.

To protect the electricity from leaking out into the water, the cable needed to be coated with a material with a very high electrical resistance. Only a flexible material that was also an insulator would do – since it had to be wound into a cable. The material that was used was gutta-percha which is a plastic made from the latex of palauquium trees. Gutta-percha is an ideal material for undersea cables in many other ways too, it does not corrode in sea water and resists attack by marine animals and plants. However it only required one breach exposing the conducting copper to corrosive sea water to cause failure. To produce a 1600 mile cable and place it at the bottom of the sea without injuring the insulation thus was a considerable achievement, especially because gutta-percha could become brittle. Gutta-percha (unlike modern plastic insulators) reacts with oxygen in air making it brittle, and so leaving the cable in the air for any length of time increased the risks of failure.

The electricity we use every day comes mostly from power stations, these are not giant batteries, but generate electricity on demand, using magnetic fields. This works because magnetism and electricity are connected: they are different aspects of the same phenomenon called electromagnetism. Thus when electricity flows, it generates a magnetic field around it, and likewise if you move a wire through a magnetic field it will generate electricity. This is called induction and is how a power station generates electricity. Induction affords the possibility of creating high voltage signals in a telegraph wire through the use of high magnetic fields. This method was used by Whitehouse to attempt to deal with the problems of the poor signal quality of the 1858 telegraph. The problem with using high voltage signal in wires is that the signals place the insulation under strain, and can break down its molecular structure. The rapid decline of the 1858 cable was blamed on such a breakdown of the gutta-percha due to high voltage signals. Induction also caused the electric signals to interact with the sea water making them weaker and harder to detect.

These days our understanding of electrical signals and how they can be controlled and used to convey information is extensive and underpins every aspect of our lives. When you plug in your earphones and listen to your music on your computer or smart phone, the music is relayed to your earphones through insulated copper wires not too dissimilar from those used on the transatlantic cable. They seem trivial to us now, but oh how the protagonists of the cable would have marveled.

1. David Bodanis, *Electric Universe: How Electricity Switched on the Modern World* (London: Little, Brown 2005).

CATALOGUE ENTRY S1 | SIGNALS

# 1866: THE YEAR COMMUNICATION CHANGED FOREVER

## MARCH: CABLE CONSTRUCTION BEGINS

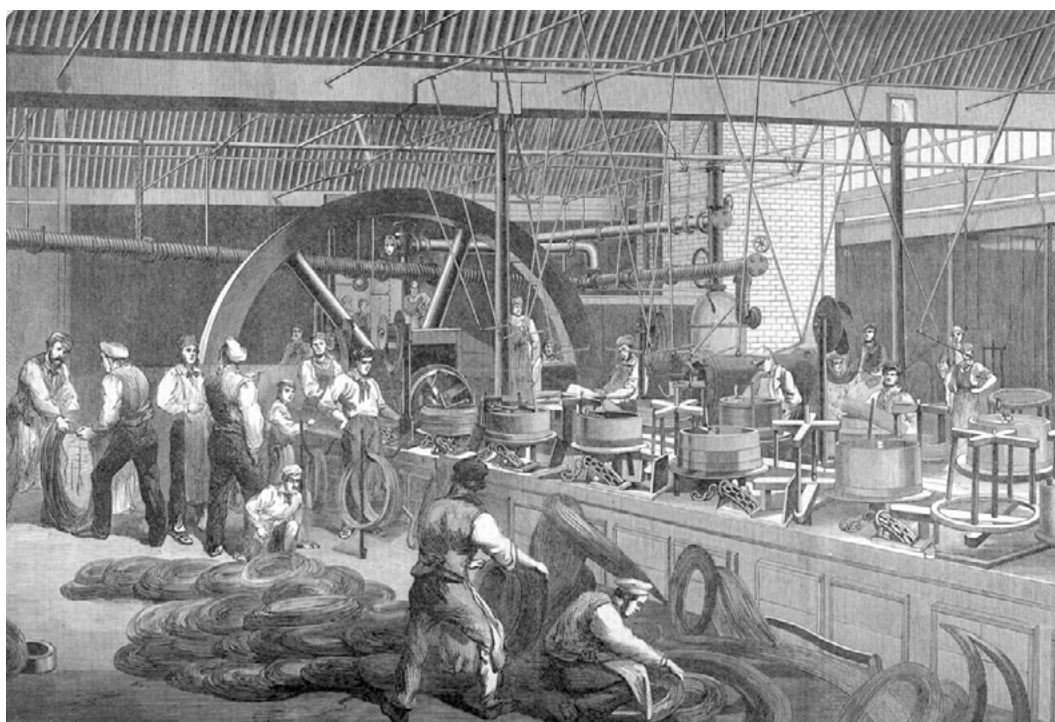

Making steel wire for the cable armouring at Greenwich, *Illustrated London News* (12 Dec, 1874), p.263. Wellcome Library, London.

The 2,300 miles of cable needed for the Atlantic telegraph was constructed in layers. A pure copper wire was coated in gutta-percha (a natural plastic). Seven strands of coated wire were then twisted together to form the core of the cable, which was wrapped in jute (hessian) and sealed with further layers of gutta-percha. The insulated core was armoured with steel wires: heavier ones for the shore end, where the cable could be damaged by anchors, and lighter for the safer deep-sea sections. A single mistake meant the failure of the whole cable, so it was electrically tested at each stage of the process.



# MAY: CABLE LOADED ON BOARD THE SS GREAT EASTERN

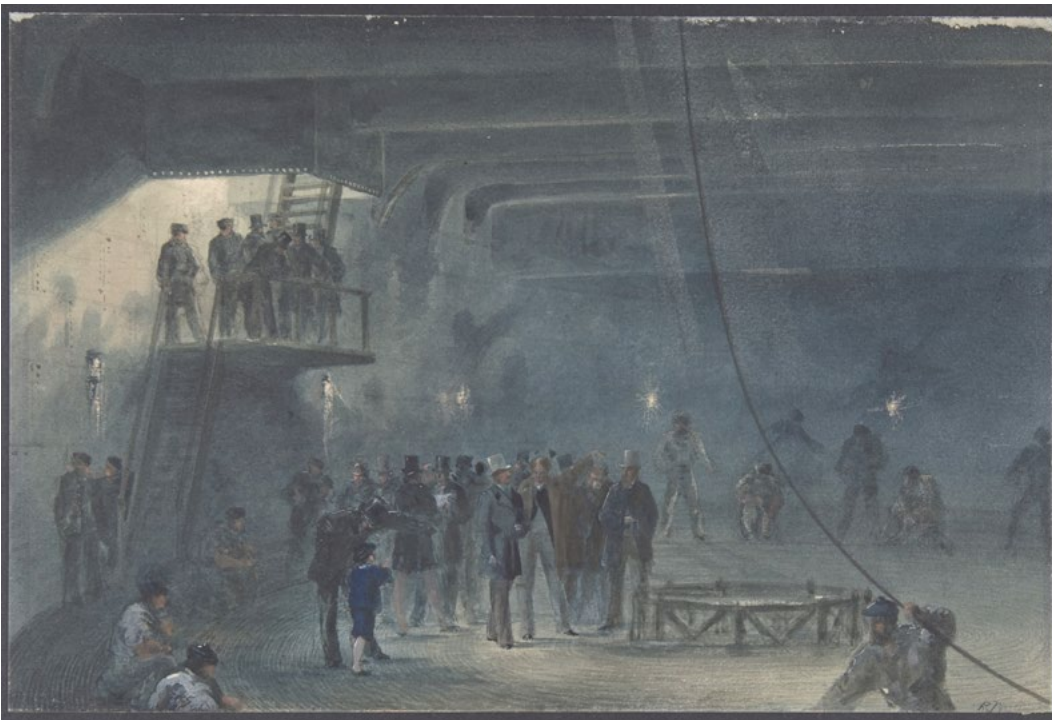

*Robert Charles Dudley, Coiling the Cable in the Large Tanks at the Works of the Telegraph Construction and Maintenance Company of Greenwich, 1865. Watercolour, [www.metmuseum.org](http://www.metmuseum.org)*

The finished cable sections were so heavy that the Atlantic Telegraph Company chartered the largest ship of the day - Isambard Kingdom Brunel's *SS Great Eastern* - to carry them. They planned every move carefully to avoid kinks and breakages. The cable was threaded onto pulleys, passed over the water and carefully coiled into tanks on two decommissioned war ships, which ferried it to the *Great Eastern* anchored at Sheerness. It was fed out of their holds into three huge salt-water tanks on the *Great Eastern* and painstakingly coiled again for the onward journey to Ireland.

## 7<sup>TH</sup> JULY: CABLE LAYING BEGINS



Robert Charles Dudley,  
*The Heights over Foilhummerum Bay, Valentia, the William Corey Heading Seawards, Laying the Shore-end of the Atlantic Telegraph Cable, July 7th, 1866.* Watercolour, [www.metmuseum.org](http://www.metmuseum.org)

The shore end of the cable was laid on 7 July at Valentia Island in Ireland, and SS Great Eastern, anchored off the coast, set sail on 13 July to begin laying it across the Atlantic. Signals were sent from the land end to the testing room on board, where an engineer was on watch 24-hours a day. If the signals faltered the ship could be stopped, and the cable hauled back and repaired. Unlike four previous attempts between 1857 and 1865, this time the weather was good and the expedition passed without incident.

## 27<sup>TH</sup> JULY: THE SHORE-END OF THE CABLE IS LANDED AT NEWFOUNDLAND



Robert Charles  
Dudley, *Landing at  
Newfoundland*, 1866.  
Oil on canvas, [www.  
metmuseum.org](http://www.metmuseum.org)

The *SS Great Eastern* arrived in Heart's Content, Newfoundland on 27 July. The end of the deep-sea section of the cable was carefully spliced to the heavily armoured shore-end of the cable. Waist high in water - and with much cheering - sailors and locals grabbed the cable and hauled it up the beach to the cable shed. Engineers worked through the night to make the link with London in time for the morning news. The project had finally succeeded.

# AUGUST AND SEPTEMBER: RECOVERING THE LOST CABLE OF 1865



Testing the recovered 1865 cable on board the Great Eastern, *Illustrated London News* (13 Oct, 1866), p.365. Wellcome Library, London.

Two weeks later, the Great Eastern went in search of the 1865 cable, lost 600 miles from shore. Four ships grappled the sea bed two-and-a-half miles down for a month. On 1 September, on their 30th attempt, they hooked the lost cable and retrieved it. Signals were sent to Ireland and after a few tense seconds the line jumped into life to wild celebration on board. The last 600 miles of extra cable were then laid back to Newfoundland. SS Great Eastern returned having laid not one but two Atlantic cables.

# A NEW ERA OF GLOBAL COMMUNICATION BEGINS



News from around the world in the Central Telegraph Office Instrument Gallery, *Illustrated London News* (12 Dec 1874), p.568. Wellcome Library, London.

By the 1870s transatlantic telegraphy was well-established. At an astounding eight words per minute the latest news criss-crossed the Atlantic bringing bulletins about reform riots in Hyde Park, war between Prussia and Italy, Napoleon arming his fleet, stocks, shares and bank rates. It brought news of Florence Nightingale, fabric prices in Calcutta, Fenian plots and attempts to assassinate the Czar alongside tips for Goodwood and the Derby. The Atlantic telegraph touched every part of life and brought the 'old world' of Europe into instantaneous contact with the 'new world' of the Americas.

CN

CATALOGUE ENTRY S2 | SIGNALS

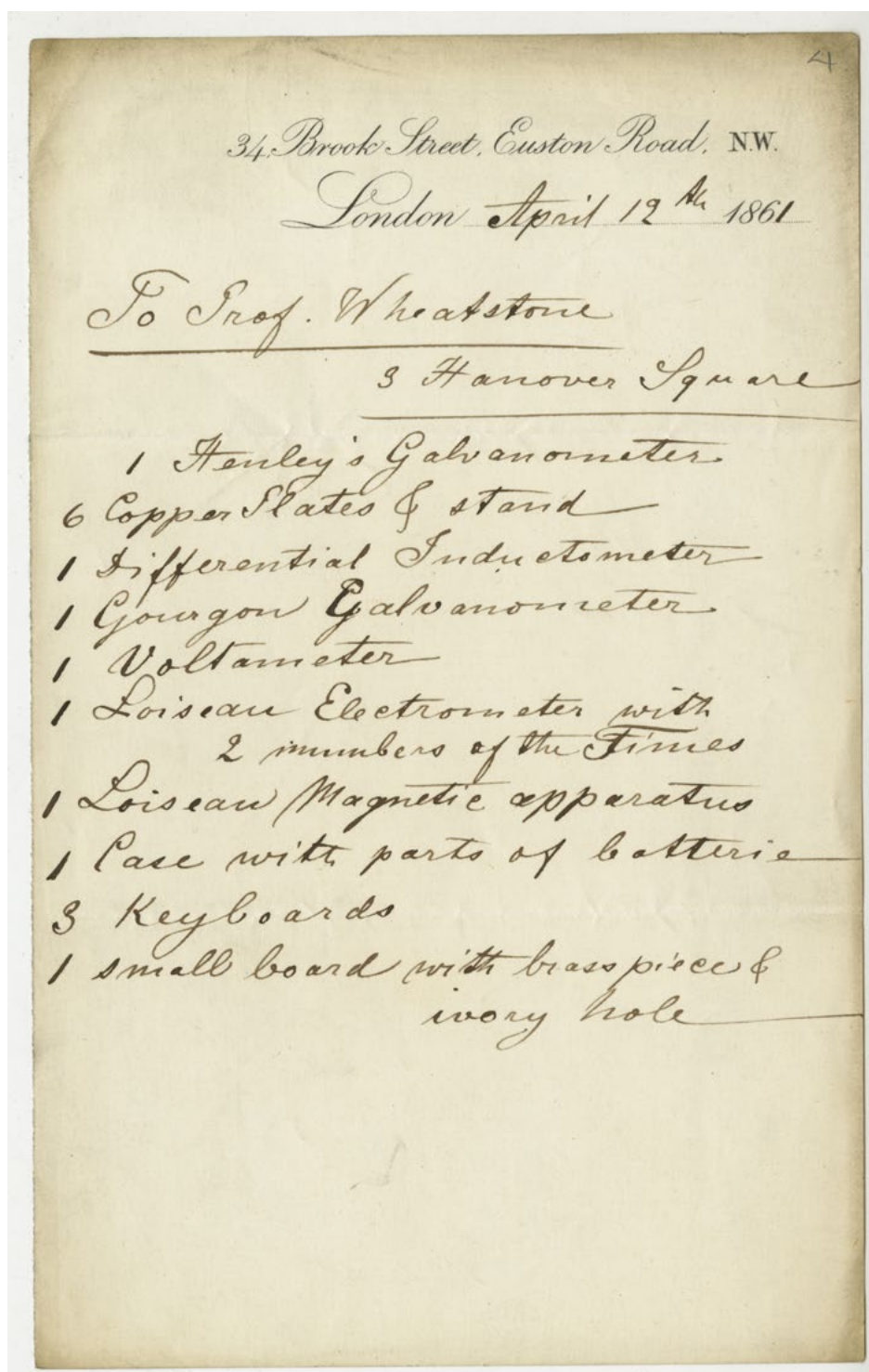
SIR CHARLES WHEATSTONE'S  
NOTES

The handwritten notes, pamphlets and (the majority of) books within this exhibition are taken from the Wheatstone Collection housed at King's College, London. They span the period of Charles Wheatstone's life from 1832, when he was appointed as the first Professor of Natural Philosophy to his death in 1875. The Foyle Special Collection at the Maughan Library houses Professor Wheatstone's personal library; the books, pamphlets and papers he collected, read and wrote over an active research career spanning five decades. There are many interesting specimens, including autographed volumes, personal gifts and several entirely unique items. Many are annotated or contain personal dedications from the author. The library reflects Wheatstone's many and varied interests, just a few of which are represented in the exhibition.

The other items on display are drawn from the half of the collection housed at the King's College, London, Strand-site Archive. These comprise Sir Charles' personal notes collected from his office at the time of his death and curated by the Physics department until the 1970s. The collection is best described as eclectic. There are his lecture notes on electromagnetism and optics (though he was famously shy of public speaking).<sup>1</sup> There are shopping lists of materials to buy to experiment with. There are sketches and diagrams of machines, both built and unbuilt. There are records of experiments, some successful, some of which are so obviously unsuccessful as to have been abandoned half way through. In short, the notes are a treasure trove, a window into the life of a Victorian inventor and academic. From this eclectic collection we selected just a handful of illustrative pieces to feature in the exhibition.

#### Distance

In the Distance case we selected a Letter from physicist James Clerk Maxwell to Sir Charles Wheatstone to represent the communication and collaboration between engineers and physicists which were key to telegraphic projects. We also selected a chart from Wheatstone's reference library and some of his notes on from meteorology, oceanography, mechanical properties of natural materials and battery design to demonstrate how the Atlantic telegraph cut across many different specialisms and brought together diverse research interests.

#### Transmission

For the theme of transmission we selected notes and pamphlets which would complement or illustrate the machines on display. For example, to accompany the galvanometer we chose an 1858 Elliot Brothers' sales pamphlet, released when they were awarded the sole contract to build and distribute Sir William Thomson's Patent Graded galvanometer. We also included some of Wheatstone's sketches for what eventually became the Alphabetical Telegraph to display alongside the exhibition's example of the final, commercially produced machine. Telegraphic engineers were constantly rethinking and redesigning the telegraph

for different uses. Also on display are Wheatstone's sketches for different telegraphic circuits and sending apparatus, including what became his famous Five Needle Telegraph.

### Coding

Charles Wheatstone was fascinated by ciphers and coding. He worked on many cipher systems including the 'Playfair Cipher'. Playfair was a favourite of the military as it encrypted pairs of letters at a time and took a lot longer to crack than existing systems. This small selection of his many notes on the subject shows him constantly experimenting with different ways to code and encipher telegraph messages. These including an interesting piece where he seems to be demonstrating to somebody how the Playfair cipher works, using 'Victoria' as the encryption key. It is often hard to discern the exact purpose of Wheatstone's coding the notes as – unsurprisingly – they are encrypted.

CN

1. B. Bowers, *Sir Charles Wheatstone FRS, 1802-1875*, IEE History of Technology Series, Vol. 29 (London: The Science Museum, 2001).



CATALOGUE ENTRY S3 | SIGNALS

# BATTERY OF TEN DANIELL CELLS

KING'S COLLEGE LONDON ARCHIVES



In 1836 the floodgates to the future opened. It was the year in which John Frederic Daniell invented his Daniell cell. The rapid economic growth and unbridled wealth creation of the Regency had left provincial society chock-full of the well-educated sons of artisans and professionals. They came of age and were drawn to London to take up the professorships in chemistry and natural philosophy being created at the new London universities. Well-financed labs were built, patrons found, scientific societies established. Funding, excitement and a great deal of scientific brain-power were applied to the project of probing the mysteries of the universe. There was one thing limiting the breakthroughs into the unknown: power.

Daniell began his career as the first Professor of Chemistry at King's College, London. His brand-new lab included the best equipment for power generation at the time: Volta's voltaic pile, a stack of alternating zinc and copper discs, separated by discs of cardboard or felt soaked in an electrolyte (brine). Daniell was using it for his experiments in electrolysis (breaking down water into oxygen and hydrogen) and noted that the pile lost voltage because a film of hydrogen bubbles formed on the surface of the copper cathode and reduced its conductivity. It was also impossible to turn off and so ran down when not

in use. Daniell designed his cell to solve these two problems. He added a second electrolyte to consume the troublesome hydrogen bubbles and kept the two electrolyte solutions separate so his cell wouldn't run down between uses.

Daniell took a zinc anode (like the negative terminal in a battery) and suspended it in a porous earthenware jar full of zinc sulphate. He initially used an ox-gullet but the earthenware jar proved nearly as good and a lot less smelly!<sup>1</sup> The earthenware jar was then placed in a copper pot filled with a copper sulphate solution. The copper pot became the positive terminal or cathode. The porous earthenware jar kept the two solutions separate but allowed charged ions to move between them. Like in a modern battery, when the negative anode was connected to the positive cathode (the copper pot) a current flowed. When the connection was broken the porous jar kept the solutions separate so the cell did not lose charge.

The Daniell cell was a massive improvement and the first really practical power source. Several cells could be connected together to form a battery and provide any required voltage. The cells were robust, portable and sufficiently simple to be assembled onsite by engineers. It was an immediate success, not only for lab experiments but also a myriad of industrial applications. Technologies, which had been limited for decades by a lack of power suddenly had access to the reliable, long-lasting, cheap and scalable Daniell cell. The greatest among these new technologies and the most transformative was Charles Wheatstone's telegraph through which - with now ample power - 'dense flocks of ideas... [started] to fly, like starlings, across the globe'.<sup>2</sup>

CN

1. Andrea Sella, 'Daniell's cell', *Chemistry World*, Royal Society of Chemistry (2012), <http://tinyurl.com/zuu67c4> (consulted 5 September 2016).

2. Ibid..

# DISTANCE

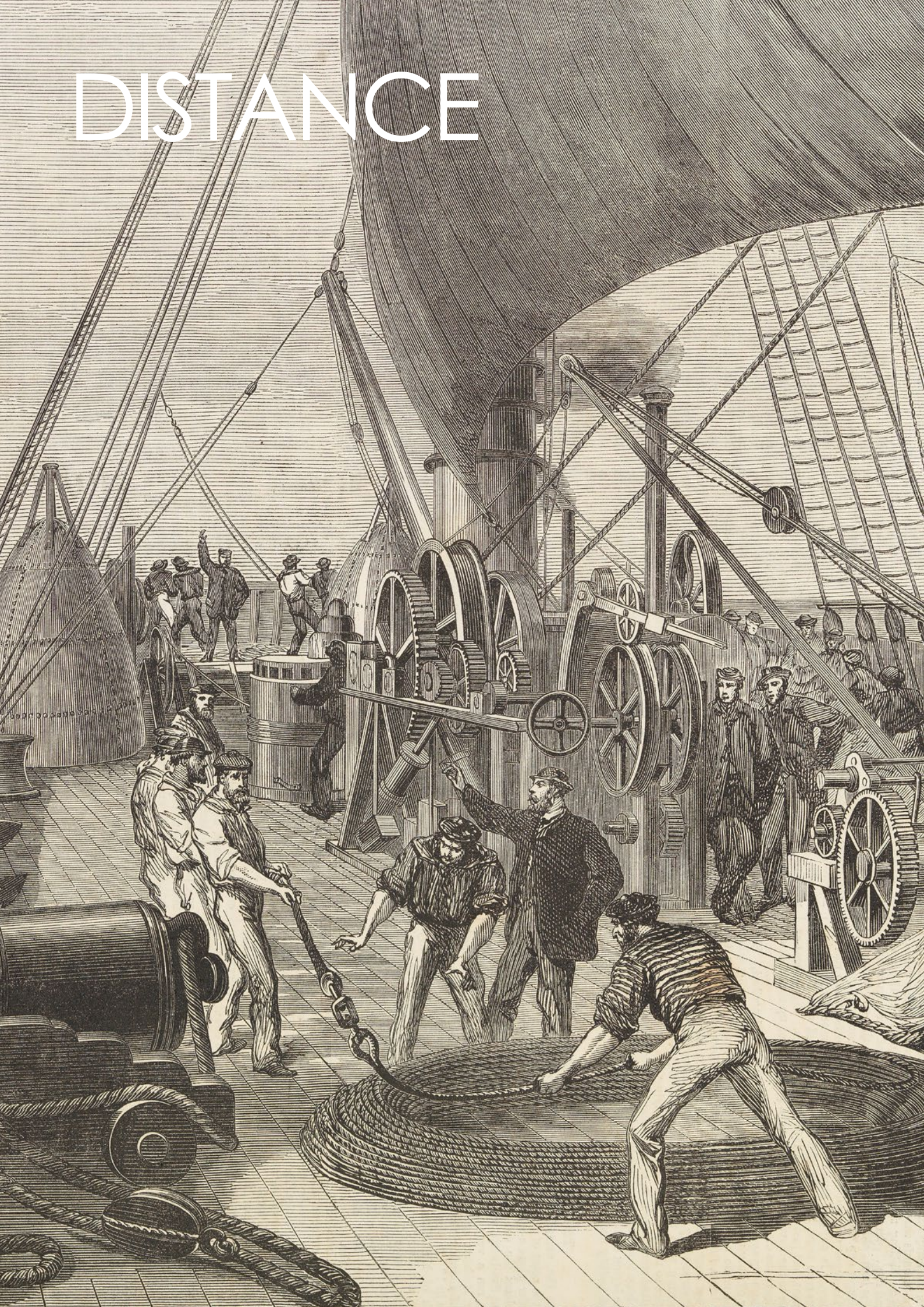

DISTANCE

# NATALIE HUME

BETWEEN THE EMPIRICAL AND THE ABSTRACT: GRIMSHAW'S *THE THAMES BY MOONLIGHT WITH SOUTHWARK BRIDGE*



Fig. 1, John Atkinson Grimshaw, *The Thames by Moonlight with Southwark Bridge*, 1884, Guildhall Art Gallery, City of London Corporation.

The high proportion of paintings in the Distance section of the exhibition testifies to the intrinsic connection between space and painting. Nineteenth-century art is often understood in terms of two broad categories characterised by divergent approaches to the treatment of space: realist and decorative. This binary split, although an oversimplification, corresponds to growing tension through the century between empiricism and abstraction. The Victorian era is often seen through a filter of proliferating ‘things’, epitomised by the Great Exhibition of 1851: material production, whether industrial or artisanal, was key to national identities and international relations.<sup>1</sup> But the century was also increasingly shaped by new intellectual traditions and theories, some of which described a disorienting process of abstraction and detachment from the conditions of materialism. Just before paper money became preeminent, a triumph of symbolic rather than intrinsic value, Karl Marx and Friedrich Engels described capitalism as a system in which ‘all that is solid melts into air’.<sup>2</sup>

It is tempting to see these apparently contrasting inclinations – towards and away from the physical world – echoed in contemporary technology, which appeared to distil this duality, packaging it in new systems and devices. Photography provided the opportunity to ‘paint with light’, potentially freeing artists from the thickness of paint but ghosting the physical world, indexically bound to its corporeal subject. Both the railway and telegraphy were ways to negotiate space and alter the experience of distance, and each required the engineering of heavy infrastructure – great lengths of track and cable – in the pursuit of speed and the instantaneous transmission of messages. The artist, like the photographer,

must confront space: whether by conjuring illusionistic depth or collapsing it in deference to the flatness of the picture plane, painting is a manipulation of space.

John Atkinson Grimshaw (1836–1893) is best known for a particular kind of moonlit landscape, urban, suburban or rural, which demonstrates an approach that was both ‘realist’ and decorative. Born into a lower-middle-class family in the North, Grimshaw lacked formal training and developed an idiosyncratic technique that made extensive use of photography. His engagement with space and treatment of light may also have borrowed from the stage: he had connections to the theatre, and his portrayal of distance, often articulated through light (for example, including silhouettes in the foreground) suggest a series of fields or layers, corresponding to ‘flats’ or painted pieces of scenery.<sup>3</sup>

*The Thames by Moonlight with Southwark Bridge*, one of a series of similar scenes, is recognisably Grimshaw in both style and content, comprising a cloudy moonlit sky, reflections on water, twinkling gaslights, silhouetted boats and a bridge. Night, like distance, diminishes the colour spectrum, eliminates detail and makes it difficult to assess space. Grimshaw seems fascinated by this interplay of darkness and distance, emphasising the blackness of the silhouettes against the uncertain depth of sky and water that cover most of the canvas. The wide-angle view opens out the landscape, accentuating its breadth and further undermining legible depth. The lack of vanishing point is most obvious in the surprisingly steep angle of the roof on the far left, which serves a dual – and perhaps paradoxical – purpose of disrupting spatial logic and providing a sense of massive proximity, lending scale to the miniaturised buildings on the far shore. The double upright posts on the left act as a repoussoir (a foreground feature leading the eye into the scene), echoed in several sets of furled sails across the water, and again far away, in the west towers of St Paul’s. This pattern of repetition pretends to map space, but instead offers a layered sequence of fields, each of which is ambiguous in relation to the others: it is difficult to judge, for example, the distance between the receding barges on the left, or from barges to bridge, or from bridge to the shore behind.

This imprecise rendering of space, along with his predilection for moonlit water, would seem to express Grimshaw’s romantic nostalgia: he loved the Romantic poets and made forays into fantasy, in *Iris* (1886, Leeds Art Gallery), for example.<sup>4</sup> In *The Thames by Moonlight with Southwark Bridge* the city seems a shadowy afterthought, insignificant against the study of light on clouds in the wide-open sky and its reflection. Such effects, cyclical but unchanging, had provided material for artists over centuries. This highlights a link between time and space, as though the night is haunted by the past, masquerading as apparently endless and indistinct space. But some of these temporal associations – particularly the suggestion of straightforward nostalgia – may be misleading. In this context, it is instructive to consider the way in which Grimshaw’s oeuvre intersects with that of a celebrated contemporary

peer. According to Grimshaw's grandson G. R. Phillips, the eminent artist James McNeill Whistler 'declared that he had thought he had invented pictorial "nocturnes" until he saw Grimshaw's moonlight pictures'.<sup>5</sup> It was hardly groundbreaking to paint the city at night (see, for example, Joseph Vernet's *Night: Seaport by Moonlight*, 1771, Louvre), so in bestowing the category of 'nocturne' Whistler was making a specific and nuanced point about Grimshaw's work. A nocturne, with its associations with darkness and water, is ostensibly associated with lyrical detachment from quotidian life, an interpretation that fits with an analysis of both artists' work as both retrograde and romantic. Whistler's innovation in applying the term to paintings, however, involved shrewd negotiation of current debates and issues: it was a commercially astute strategy that simultaneously branded the nocturne as fashionably 'Aesthetic' and issued a provocative statement about the status of visual art.<sup>6</sup> Given the two artists' stylistic divergence, Whistler's comment underlines that their affinity lies in content: both produced series of desolate, moonlit cityscapes that included artificial light and conspicuous references to industry.<sup>7</sup> More subtly, Whistler may well have recognised in Grimshaw's work a kind of detachment and abstraction that could be mistaken for romantic nostalgia but was conversely absolutely of its own time.

In *The Thames by Moonlight with Southwark Bridge*, the string of lights across the dark centre of the city forms an artificial horizon, providing definition to the indistinct topography. This is an environment animated not by life but by light: the boundless radiance of the moon is answered by glowing points of gas streetlighting, a relatively recent development.<sup>8</sup> Further west, the first electric arc lights had just been installed on Thames Embankment near Westminster, in 1878. These cannot be seen in *Thames by Moonlight*, but they do appear in Grimshaw's *Reflections on the Thames: Westminster* (Fig. 2), where they participate in the interaction between natural and artificial light. In that picture the striking white electric discs recede along the water, echoing the silvery moonlight, in contrast to the warm yellow gaslights on the other side of the pavement and the golden clock face of Big Ben, an artificial analogue of the chronometric moon. Despite the amorphous expanse of river and sky, the picture is carefully proportioned and metered, a study in distance and recession. The lines of arc lights and gaslights draw together as the bank curves away into the distance, producing an illusion of orderly depth; the illuminated coping stones and paving slabs emphasise the rhythm, also apparent in the architecture of the bridge and the string of barges. Electricity and gas power, under the auspices of the moon, map time and space and bring order to the city.



Fig. 2, John Atkinson Grimshaw, *Reflections on the Thames: Westminster*, 1880, Leeds Museums and Galleries (Leeds Art Gallery) UK / Bridgeman Images.

The accent on measurement may offer a clue to Grimshaw's interest in cosmic light, particularly in the context of the city. The 'light-year' first appeared as a unit of distance in 1851, with the speed of light being slightly amended in 1862 to within 0.6 per cent of its present-day figure as a result of experiments by Léon Foucault, using Charles Wheatstone's revolving mirror.<sup>9</sup> The discovery that light travels with a constant speed of nearly 300 million metres per second had become an important means for calculating vast distances; the way in which the moon reflects light from the sun evokes the enormity of space and the relationship between space and time. Grimshaw's focus on the illumination of clouds and reflections on water draws attention to these ideas and puts them in dialogue with mechanical time, quantified space and regular streetlighting.

Grimshaw's interest in energy, time and space persists in the picture featured in this exhibition, *The Thames by Moonlight with Southwark Bridge*. This part of the city lacks the blaze of electricity and the metropolitan glow of Big Ben so the mapping of space is far more ambiguous, but the tiny glowing dots of gas signify an expanding city. Cosmic light offered a way to think about unimaginably large distances, bringing a modern perspective to humanity's understanding of the universe (a literal Enlightenment); at the same time, artificial light was essential for the flourishing of modern life, bringing productivity to winter months and opportunities for consumption to the hours of evening leisure. Despite giving an impression of congealed stillness, *The Thames by Moonlight with Southwark Bridge* is nevertheless invisibly driven by flow, with all its significant components – river, moonlight, gaslight, clouds, boats, bridge – defined by movement and energy transfer.

The rigid, stagy look of the picture is likely to be a vestige of the role played by photography (and perhaps of the theatre) in Grimshaw's creative process. A certain nostalgia may be intrinsic to that technology, despite its continuing novelty and transformation in the 1880s, but it is one that is so self-conscious as to be almost ironic: the still photographic image stands explicitly for a lost moment. This may be part of what lies behind Grimshaw's ability to produce an atmosphere of idealised timelessness with an unsettling sense of contemporaneity. The iron bridge, then only sixty-five years old, is a symbol of growing industry and commerce; the characteristic Thames sailing barges are scattered across the water, sails furled, waiting for daylight. Three distinct sets of paired sails are silhouetted emphatically against the water and sky, rhyming with the twin towers of St Paul's in the distance and suggesting a comparison between the old routine based around the call to prayer and the new one, following the call of commerce.

The human presence, though, is indirect, almost disavowed. The scene is visually appealing – even picturesque – but there is something ominous and unfriendly about the sharply pointed, crouching city. The pretty reflections on the water are intrinsically melancholy, partly because they are somewhere else (F. Scott Fitzgerald articulated this yearning desolation years later in the similar image of Gatsby gazing across at the distant green light on Daisy Buchanan’s dock).<sup>10</sup> The scene is arranged as though viewed from somewhere in the water, or among the shoddy boats, but the distortion is disorientating: although conventional devices lead into the attractive, the viewer nevertheless cannot belong there. The heavy black bridge crossing the river repudiates its function in connecting the city; instead, it isolates the viewer in a non-place before the picture, separating the dark, flooded ‘here’ from the illuminated, metropolitan ‘there’.<sup>11</sup> The resulting sense of isolation and dislocation is apposite given the degree to which Grimshaw’s worked has been overlooked in comparison with some of his contemporaries.<sup>12</sup>

The distance in *The Thames by Moonlight with Southwark Bridge* is evoked across a spectrum of contexts: wide space across the canvas, the pictorial depth receding into the scene, city quietly growing as it sleeps. But the distances that are most cleverly evoked are unseen. The water is covered with an all-over pattern of ripples that emphasises its surface; this diminishes its description of distance towards the horizon but acts like a veil, suggesting that the hidden depths might be bottomless. The clouds, their patchy pattern reflected beneath them, similarly hang before the moon, as though masking a space so overwhelming that it cannot be shown. Hubert Damisch has proposed that clouds historically produced a problem and also liberated painters from the requirements of iconography and spatial representation, offering an opportunity for fantasy, mystery and oblique commentary.<sup>13</sup> This function is sustained into wider culture, from the ancient game of visualising images in the sky to the ‘cloud’ as a repository for digital data: constantly changing, amorphous, insubstantial and voluminous, clouds have a special affinity to phenomena that are intangible or indefinable. Grimshaw’s clouds, rendered both realistically and decoratively, offer a literally nebulous rendering of contemporary life, both benighted and enlightened, empirical and abstract. As a cultural medium that explored the boundaries and implications of space, visual art could not fail to respond to new technologies – notably photography, rail travel and telegraphy – that seemed to devour both space and time. The action of natural and artificial light upon clouds and water, despite the image’s apparent stillness and superficiality, offers an oblique manifestation of contemporary preoccupations such as travel, flow, transformation, matter and energy.



1. See, for example, Asa Briggs, *Victorian Things* (1988) (London: Penguin, 1990). I use 'Victorian era' as a geographical as well as a temporal identifier, to mean Britain and its sphere of influence.
2. Karl Marx and Friedrich Engels, *Manifesto of the Communist Party* (1848) in Robert C. Tucker (ed.), *The Marx-Engels Reader*, 2nd edition (New York: Norton, 1978), pp. 475-6. Paper money became much more significant following the circulation of fully printed, unsigned banknotes by the Bank of England from 1855. <http://tinyurl.com/hr5nogr> (consulted 23rd August 2016). The United States experienced a gradual transition to legal tender notes in the early 1860s. <http://tinyurl.com/hsjow52> (consulted 23rd August 2016).
3. Frank Milner argues convincingly that both photography and theatre were important sources for Grimshaw as a developing artist. He also elucidates the connections between photography and the theatre, as, for example, the sophisticated use of 'colour-slide projection ... for special effects in the theatre'. Frank Milner, 'The Mystery of the Self-Taught Pre-Raphaelite', in Jane Sellars (ed.), *Atkinson Grimshaw: Painter of Moonlight* (London: Mercer Art Gallery and Guildhall Art Gallery, 2011), p. 31.
4. Grimshaw shared with many of his contemporaries a fascination with medieval culture, naming his children after characters in poems and legends, collecting armour and renting a house with battlements. Alexander Robertson proposes that Grimshaw imbued his paintings 'with an atmosphere and sense of poetic nostalgia' as 'a way of coping with the changes all around'. Alexander Robertson, 'Atkinson Grimshaw: Life and Work', in Sellars, *Atkinson Grimshaw: Painter of Moonlight* (2011), p. 11.
5. Guy Ragland Phillips, unpublished memoir, quoted in Mark Bills, 'Atkinson Grimshaw in London', in Sellars, *Atkinson Grimshaw: Painter of Moonlight* (2011), p. 76.
6. Whistler's analogy of painting with music was polemical: 'the artist is born to pick, and choose ... as the musician gathers his notes, and forms his chords, until he bring forth from chaos glorious harmony.' This position was associated with Whistler's defence of art from critics, whose influence 'has brought about the most complete misunderstanding as to the aim of the picture. For him a picture is more or less a hieroglyph or symbol of a story.' James Abbott McNeill Whistler, *The Gentle Art of Making Enemies* (1890) (London: William Heinemann Ltd, 1994), pp. 143, 146.
7. A few of Grimshaw's very late paintings do resemble those of Whistler stylistically – see, for example, *Sand, Sea and Sky: A Summer Fantasy* (1892, private collection) and *The Port Light* (1890s, private collection) – but these are a departure from the night-time pictures he was producing in preceding decades.
8. Gas lighting was introduced into the London streets from the early 1800s and spread quickly around the busier parts of the city.
9. [https://en.wikipedia.org/wiki/Light-year#cite\\_note-22](https://en.wikipedia.org/wiki/Light-year#cite_note-22) (consulted 31 August 2016); [www.wikipedia.org/wiki/L%C3%A9on\\_Foucault](http://www.wikipedia.org/wiki/L%C3%A9on_Foucault) (consulted 31 August 2016).
10. The green light, an enduring image of desolate hope, is associated with distance in space and time as well as detachment. 'Gatsby believed in the green light, the orgiastic future that year by year recedes before us. It eluded us then, but that's no matter – tomorrow we will run faster, stretch out our arms farther. ... And one fine morning – So we beat on, boats against the current, borne back ceaselessly into the past'. F. Scott Fitzgerald, *The Great Gatsby* (1925) (Basingstoke and Oxford: Pan Macmillan, 2013), p. 233.
11. Some biographical details might be relevant here. In 1879 Grimshaw suffered a financial disaster that apparently led him to move temporarily away from his wife and children into London. But by the mid-1880s Grimshaw had returned home, and unlike his Chelsea neighbour Whistler, an American who had lived in Paris, Grimshaw seems always to have been an outsider.
12. Of the association between Grimshaw and Whistler, Mark Bills writes that 'it seems ... the closeness of their friendship is exaggerated as books on Whistler fail to mention Grimshaw even in passing'. Bills, 'Atkinson Grimshaw in London', in Sellars, *Atkinson Grimshaw: Painter of Moonlight*, (2011).
13. Hubert Damisch, *A Theory of /Cloud/: Toward a History of Painting*, translated by Janet Lloyd, (Stanford: Stanford University Press, 1972).

DISTANCE

# ANNE CHAPMAN

*PROFOUND REPETITION: HOOK'S DEEP SEA FISHING*



Fig. 1, James Clarke Hook, *Deep Sea Fishing*, 1864, Guildhall Art Gallery, City of London Corporation.

At the time when James Clarke Hook painted a trio of fishermen trailing their lines beneath the waves in *Deep Sea Fishing*, the study of ocean topography was a nascent science and expertise in the seas' depths was developing. For those attempting to realise a transatlantic telegraphic connection, depth presented as much of a problematic distance as the great expanse across the Atlantic Ocean did. Only a decade before the cable laying attempts of 1857 and 1858 these depths were an unknown, an as yet unexplored territory. At first attempts to measure and map this new frontier arose from both the need to traverse the ocean swiftly and safely and from the interests of the whaling industry. This then developed into a scientific quest for understanding exploited by those involved in the transatlantic telegraph project.<sup>1</sup> Just as fishermen benefit from both appropriate technology and experience in order to make their catch where they cannot see, so hydrographers' exploration of the seabed relied on interpretation of information mediated by technology, an interpretation which they could only hone over time. This repeated practice and experience transformed the ocean's depths from a dangerous unknown to a safe bed for the transatlantic cable.<sup>2</sup>

In order to ascertain the topography of the ocean, hydrographers measured depth by sounding, a process in which a leadsman dropped a weight attached to a line over the side until it hit the bottom (although 'echo sounding' has its origins in the nineteenth century, it was not successfully utilised until the twentieth).<sup>3</sup> This method could take up to three hours and even then hindrances of weather and water would produce inaccuracies.<sup>4</sup> Accuracy also depended partly upon a haptic subtlety employed with increasing difficulty as the distance to the ocean floor increased: Rozwadowski explains that 'hydrographers claimed they felt the impact in deep water' yet relied also on the visual signals of the line stopping or slowing.<sup>5</sup> Both of these were, of course, subject to human fallibility.

Comprehension of the seabed required both multiple repetitions and improvements in technology. Different soundings of the same area could produce very different results. The four profiles shown in Fig. 2 appear in the 1858 enlarged edition of *Explanations and sailing directions to accompany the wind and current charts* and with them naval officer and oceanographer Matthew Fontaine Maury illustrates the unreliability of information gathered by this method: each very different profile represents the same section of the Atlantic bed. Mid-century hydrographers could not exhibit the same confidence in the results of their dropping lines into the ocean as that of the fishermen dangling their lines in *Deep Sea Fishing*.

*Deep Sea Fishing* is one of many marine scenes painted by Hook. He was one of a number of Victorian painters who specialized in coastal scenes which 'catered for the hankering of the townsman after the sea'.<sup>6</sup> Much of his work was held in great esteem during his career. Ruskin declared in *Modern Painters* that '[t]he designs of J. C. Hook are, perhaps,

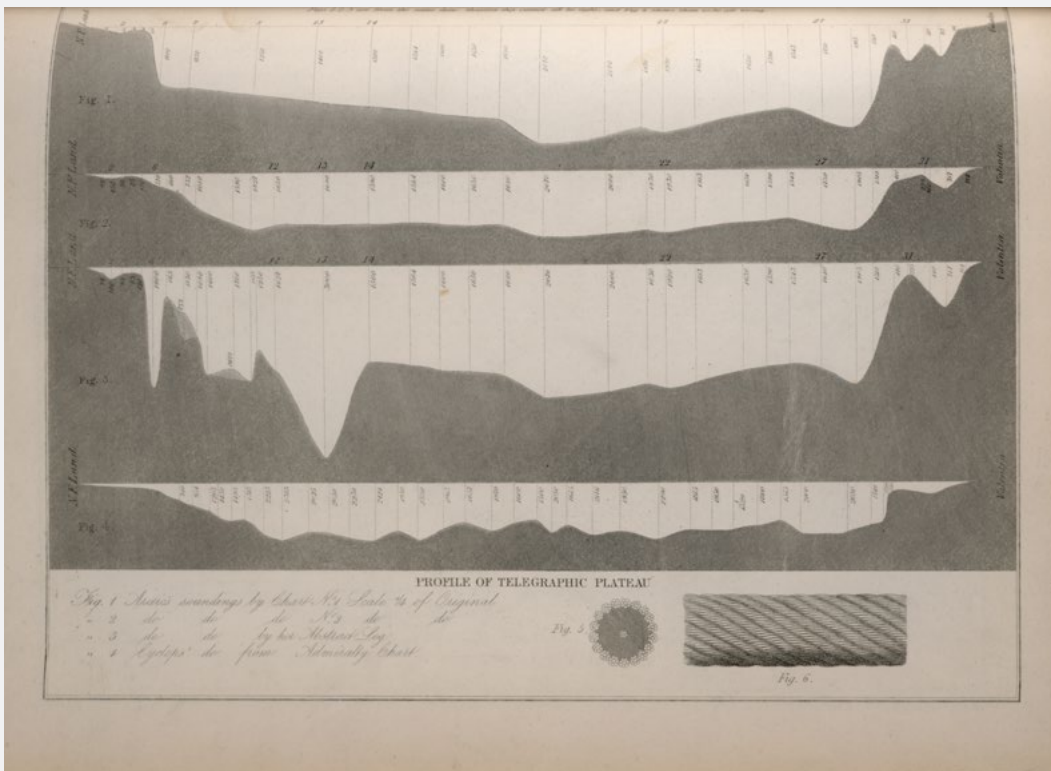

Fig. 2, 'Profile of Telegraphic Plateau', in M. F. Maury, *Explanations and sailing directions to accompany the wind and current charts* (Washington: William A. Harris, 1858 [eighth edition, enlarged]), Plate XII. Image: King's College London, Foyle Special Collections Library.

the only works of the kind in existence which deserve to be mentioned in connection with the pastorals of Wordsworth and Tennyson.<sup>7</sup> When Ruskin reviewed the Royal Academy exhibition of 1859, he much admired another of Hook's marine paintings, *Luff, Boy!*: 'A glorious picture — most glorious'.<sup>8</sup> Hook became an Associate Academician in 1850 and a full Royal Academician in 1860. *Deep Sea Fishing* was not exhibited at the Royal Academy, and Hook's execution of human scale in it is, in places, questionable. Nonetheless, the painting communicates the relationship between knowledgeable human experts and the depths of the sea.

Three fishermen of different ages lean over the stern of their vessel hanging their lines into the water below. They fish at a distance neither we nor they can see. Whilst this is, as the title makes clear, deep sea, and its colour suggests a churning ocean, Hook reminds us of the transparency of the water into which we look: he picks out some of the boat's hull beneath the swell and reddish brown swirls suggest seaweed agitated by the sea's surge. The surface clarity of the water invites us to look in only to have our vision quickly impeded by depth; the distance to which the fishing lines must reach is concealed although flashes of white froth mark their point of entrance into the murk below.

This type of fishing uses a hand-line rather than a rod. The fishing lines depicted by Hook, their twisting strands touched with flashes of light, would have been coarse in order to facilitate a tactile exploitation of depth. With hands unprotected and with the action out of sight, this must have been a trying task. Yet Hook's men display no strain or exertion in their faces and their bodies relax. The man to the right of the picture has perhaps caught something as his line angles away from him, tauter than the perpendicular others. Nonetheless his line runs through his thumb and forefinger with no appearance of the application of pressure and the rest of his fingers loosely bend a little. As John Bickerdyke explains of hand-line fishing in 1895, 'immediately a bite is felt, the fisherman should haul in the line, hand over hand' and '[t]he snooding or portion of the tackle immediately next to the hook must be a good deal stronger than if a rod is used [...] it is impossible to prevent sudden strains and jerks which are certain to break light tackle'.<sup>9</sup> The man with the likely catch displays no evidence of the physical exertion that 'hauling' requires. In portraying this effortless strength Hook suggests the skill that arises out of repeated practice.

The boat, its occupants, and the sea immediately in front of it fills the canvas. As it focuses on oceanic depth, *Deep Sea Fishing* obscures surface distance; it presents only the smallest section of the horizon and we cannot discern how far the boat has sailed from its harbour. The painting does, however attend to the significance of the expanse of time: paint has worn away from the boat's hull, its planks weatherbeaten, and lines age the countenances of the two men who face us. Such wear is the mark of experience, of repetition. The fishermen, in appearing to span three generations, suggest the repetition attendant on inheriting the traditions of a skilled trade. We can see the marks of repetitive toil in the ingrained dirt under and around their fingernails. Moreover, Hook places the eldest, marked by his white whiskers, centrally, intimating his importance; his glance catches our attention as he confidently looks up at us from his task, so experienced he need not focus on his fishing line. As Ben Highmore explains in *Ordinary Lives* '[o]ne person's ordinary is another person's extraordinary [...] ordinariness is a process (like habit) where things (practices, feelings, conditions and so on) pass from unusual to usual, from irregular to regular'.<sup>10</sup> These skilled men are not troubled by the demands of the task they undertake in the depths beneath them. By presenting three generations of fishermen performing their feat without any surface signs of challenge, Hook's genre painting implies that repetition transforms that which could be deemed to be difficult into the quotidian.

Hook makes a contrast which emphasises this as he places the viewer at an unusual and difficult distance from an active boat. Close enough for the boat to obscure most of the horizon, we look up from the water as the waves rise away from us. In making eye contact with the viewer, the central fisherman's glance makes us participants in the scene, not mere onlookers. However, with no indication of another vessel beneath us, we look from a position seemingly impossible to all but a swimmer. *Deep Sea Fishing*, the representation

of a single moment in the complicated work of the fisherman, suggests a challenge in transient attempts at comprehensive understanding of the expertise of the everyday.

Hook's painting implies a closeness between these experts and their ocean. His palette effects a correlation between the fishermen and their environment, in spite of the incomprehensibility of its depths. The browns, greys, and blues of the men's clothing repeat not only in the boat in which they travel but in the sea on which they sail. In their review of the Royal Academy exhibition in June 1863, the *Art Journal* notes this to be typical of Hook in reference to another of his paintings, *Prawn Catchers*: '[t]he colour of this rich composition is compounded after Mr. Hook's wont [...] thus it is that his figures comport so completely with the landscapes in which they are made to blend, nature and humanity meeting as it were each other half way'.<sup>11</sup> The marine name of the boat, *Wave*, clearly visible as the water strikes the vessel, further emphasises the closeness rather than distance between the natural world and the human technologies used to exploit it.

Hook presents a scene of human exploitation of the natural world in which three experts tackle the hidden depths of the ocean to provide food for others, a scene provoking no drama, no strain, no fear. They relax as they employ a simple line and the gentlest of touches. This is a moment in which experience calms the challenge of concealed distance beneath the rolling waves. The Victorian viewers of the picture could not fully share this serenity. Hook was painting at a time of developing knowledge of the underwater world. His composition places the viewers awkwardly in relation to the vessel and reminds viewers of the difficulty of comprehending a deep sea. The picture conveys the stretching of time through successive generations and its subdivision through endless repetition of fishing procedure. This extensiveness of time summons up the immensity of the ocean.

1. For a detailed explanation of this development see Helen M. Rozwadowski, 'Technology and ocean-scape: Defining the deep sea in mid-nineteenth century', *History and Technology*, vol. 17 (2001).
2. Rozwadowski, 'Technology...' (2001), pp. 219-220.
3. Sabine Höhler, 'Depth records and ocean volumes: Ocean profiling by sound technology, 1850-1930', *History and Technology*, vol. 18 (2002), pp. 129-131.
4. *Ibid.*, p. 124.
5. Rozwadowski, 'Technology...' (2001), p. 224.
6. Julian Reuherz, *Victorian Painting* (London: Thames and Hudson, 1997), p. 118. The 2013 exhibition *Amongst Heroes* recently demonstrated the breadth of this popular genre with a focus on Cornish scenes. The exhibition, curated by Roo Gunzi, included *Deep Sea Fishing*. (See the exhibition catalogue: *Amongst Heroes: the Artist in working Cornwall* (London: Two Temple Place, 2013), <http://tinyurl.com/z7o86xc> (consulted 11 September 2016)).
7. John Ruskin, *Modern Painters*, vol. v (1860), in E. T. Cook and Alexander Wedderburn, *The Complete Works of John Ruskin* (London: George Allen, 1903-1912), vol. vii, p. 342, <http://tinyurl.com/kpxtosm> (consulted 11 September 2016).
8. Ruskin, *Academy Notes*, no. v (1859), in Cook and Wedderburn, *The Complete Works...* (1903-1912), vol. xiv, p. 228.
9. John Bickerdyke, *Sea Fishing* (London: Longman's, Green, and Co., 1895), p. 267.
10. Ben Highmore, *Ordinary Lives: Studies in the Everyday* (London: Routledge, 2011), p. 6.
11. 'The Royal Academy', *Art Journal*, vol. 18 (1863), p. 113.

DISTANCE

# CASSIE NEWLAND

CHATTERTON'S COMPOUND

Chatterton's compound was an adhesive invented by John Chatterton of the Gutta-Percha Company. It swiftly became one of the material mainstays of the submarine cable industry.<sup>1</sup> It was developed to address a long-standing problem in the manufacture of submarine cable whereby the layers of gutta-percha insulation would separate from each other and from the copper core.<sup>2</sup> Chatterton's compound was applied to the copper conductor before the application of the first layer of gutta-percha and also between every subsequent layer of gutta-percha. A further and final covering was sometimes applied to the finished core to aid in the adhesion of the hemp or jute wrapping.<sup>3</sup> Ayrton in his *Preliminary catalogue of the apparatus in the Telegraph Museum* gives the recipe for Chatterton's Composition as being by weight:

One part Stockholm tar

One part resin

Three parts gutta-percha.<sup>4</sup>

These ingredients were heated together to form a viscous liquid. The copper conductor or partially formed cable core would then be pulled through a hot bath of the compound immediately prior to the application of the gutta-percha.

Stockholm Tar is a pine tar, the name refers not to tar made or manufactured in Stockholm but to all tar exported by the Norrländska Tjärkompaniet. Known variously as The Swedish Tar Company or The Stockholm Tar Company, the company had been granted an export monopoly in 1648 by the King of Sweden.<sup>5</sup> This gave them exclusive rights over the export, carriage and sale of Swedish tar, ensuring that every barrel of tar produced in Sweden was brokered, shipped and sold exclusively by Swedish traders at whatever price the market would support. The moniker 'Stockholm' stems from the practice of burning the name of the port of export on the side of every barrel. As Stockholm had become the only legal port of export, Stockholm Tar became synonymous with Swedish tar in general. The Swedish Tar Company continued to trade under various names and in various guises for several hundred years. Gamble notes that the monopoly was still in place at the turn of the twentieth century.<sup>6</sup> The monopoly, though despised internationally, ensured that only tar of consistent quality was exported from Sweden. Buyers could be assured that all barrels had been inspected and graded. Stockholm tar consequently earned itself a reputation as not only being of a consistently good quality but as the very finest available. Kaye notes that even the lowest grade of Swedish tar was still considered to far outstrip its rivals from Russia and the United States in terms of quality.<sup>7</sup> Stockholm tar was therefore the product of choice for all naval, military and industrial purposes, indeed, it dominated the naval stores market well into the twentieth century.<sup>8</sup> Prices were (as the saying goes) reassuringly expensive, kept high by the Swedish traders.

Stockholm tar is produced using traditional methods, which appear to differ little either by region or by antiquity. Villstrand argues that the methods of production remained



static from 1600 onward.<sup>9</sup> Tar is produced in a structure known as a *tjärdal*, literally ‘tar valley’ in Swedish, as the method of construction involves the digging of a trench or ditch into the slope of a hillside. A pipe, or a timber trough is laid along the bottom of this trench. A funnel-shaped pit is then created at the high end by the erection of bank separating it from the downhill slope.<sup>10</sup> This creates the distinctive funnel shape earthwork which is to be found archaeologically. The pit is then lined with either birch bark or flat stones to prevent the tar seeping into the ground during burning. The funnel-shaped pit would be carefully stacked with pine timber, covered with peat or white moss and burnt in a controlled manner for several days until the tar runs down the trench and can be caught in barrels at the bottom. The second ingredient in Chatterton’s compound is resin. Other sources substitute the word rosin. These are not necessarily typographic mistakes or contradictory suggestions as rosin is simply a kind of resin. From the mid-nineteenth to the mid-twentieth centuries rosin was by far the most common type of resin in production. Rosin was a staple of the naval stores industry (which also included tar, pitch, turpentine and timber) and may therefore be considered the only likely candidate for the ‘resin’ employed in the manufacture of Chatterton’s compound. Rosin is a product of the pine tree. When wounded, a pine tree produces a gum to seal the site of the injury. This gum can be collected by tapping and distilled to produce two of the staples of the naval stores industry: turpentine and rosin. When the gum from a particular tree had been exhausted it was given over to the lumber industry to provide other naval stores, timber, tar and pitch.<sup>11</sup>

The rosin from the Longleaf pine is particularly plentiful and free-flowing and so the centre of world rosin production was therefore in the Longleaf pine forests of the south-eastern states of the USA. The ‘piny woods’ stretching from North Carolina, through South Carolina, Georgia and Alabama in a coastal band 60 to 80 miles (97 to 129km) wide, some 60 to 90 million acres (24 to 36 million hectares).<sup>12</sup> The largest producer of turpentine and rosin was North Carolina.

Frederick Olmstead, a travel writer in the 1850s, notes that North Carolina’s prominence in the industry was due to several interacting factors both of which had their roots in the slave economy and its ample labour supply. First, land in the south was generally worked for profit rather than subsistence. Whereas the pine forests of South Carolina, Georgia and Alabama could be profitably logged, cleared and turned over to the raising of plantation crops, such as cotton, the soil of North Carolina was generally unsuited to this. The only large-scale industry able to turn a profit in North Carolina (except rice in the squishy bits) was therefore ‘turpentineing’, as the parallel practices of producing both turpentine and rosin were known. A second factor identified by Olmsted (writing in 1856, before the Civil War and the subsequent abolition of slavery) was the vital importance of slave labour at the inception of the industry. He suggested that it was only the low-cost labour provided by an

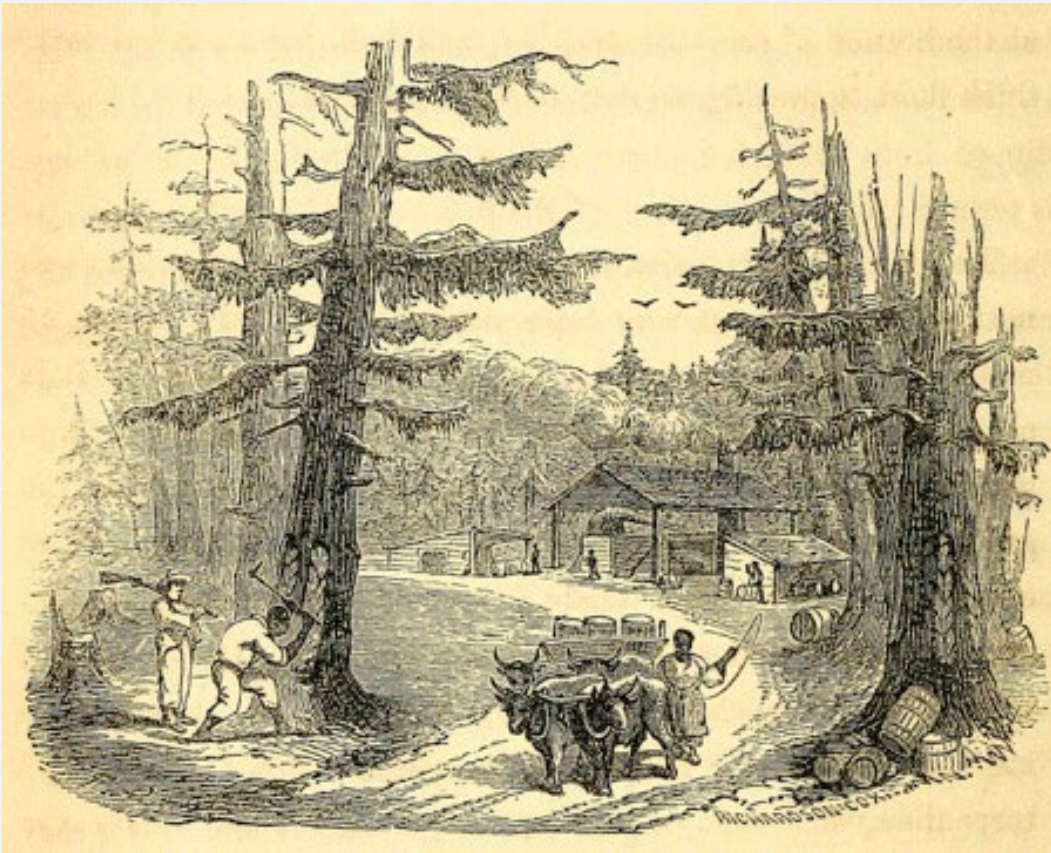

Fig. 1, F. L. Olmsted, A journey in the seaboard slave states: with remarks on their economy (New York: Dix & Edwards, 1856), p. 344. This is a North Carolina scene. Rosin is being collected from a pine tree (bottom left) and a forest distillery is in the background.

inherited slave stock (about 35 per cent of North Carolinian families owned slaves)<sup>13</sup> that allowed the labour-intensive practice of turpentine not only to turn a healthy profit but to develop in the area at all.<sup>14</sup> Indeed, the slump in naval stores production from throughout the slave-holding states after the American Civil War (1861-65) was not reversed until rising international prices for rosin and turpentine allowed the industry to run at full market wages.

The following description of turpentine collection and distillation is largely taken from Olmsted's experiences of travelling through the Old Southern States in the mid 1850s. The descriptions would still appear to be a valid characterisation of the industry in the 1870s because, as Outland notes:

Gum harvesting changed none at all ... The tools and equipment also remained the same. Boxing axes, hacks, pullers, dippers, scrapers, and stills were neither improved nor replaced. This lack of advancement was not an unusual characteristic of southern industry.<sup>15</sup>

Preparing a suitable forest began in November and ended the following March. These

initial months were spent engaged in 'boxing'. Boxing was the cutting of an angled hole at the base of a pine tree approximately 20 to 40cms wide and 7 to 10cms deep. The box sloped inward towards the heart of the tree to create a kind of hollow container within the trunk which could contain one to two litres. The number of boxes cut into any given tree was dependent on size, with a large tree being able to sustain three boxes. A strip of bark about 10cms wide (or the width of a man's palm) was left between each box to sustain the tree. Outland notes that experience was an important factor in judging box placement. Factors, such as the angle of lean, trunk shape, and predominant weather conditions had to be taken into consideration.

Once the boxes were in place they were 'cornered', a process whereby triangles were cut into the top corners of each box to channel the gum. From this moment the gum would begin to flow into the box. To maintain the flow of gum the tree had to be 'chipped' at intervals (depending on the age of the box and the season) which involved cutting away a strip of bark directly above the box to reveal a new patch of undamaged phloem referred to as the 'face'. Repeated chipping led to a slow upward creep of the exposed face, with older trees being chipped to a height of three metres or more. The gum would be collected from the boxes using a 'dipper' (the same shape as the constellation).

The distilling process generally lasted between two and two and a half hours and resulted in two products, rosin and turpentine.<sup>16</sup> On heating to around 300°C the turpentine floated to the top and was run off into the condensing coil where it was cooled and decanted into barrels. The heavier liquid rosin remained in the still. This was then cooled until it had obtained the consistency of molasses at which point it was passed through a series of screens designed to filter out the debris and foreign matter acquired during harvesting. Rosin could be packed into cheap and shoddy barrels as it quickly set to a solid preventing leakage during transport.<sup>17</sup>

The UK was the largest single consumer of rosin, importing hundreds of thousands of barrels annually.<sup>18</sup> The vast majority of those barrels ended up on the wharves of the cable factories in London where they sat alongside the Stockholm tar from Sweden: two materials taken from trees, which though related by species, were separated by several thousand miles of Atlantic ocean. Inside the factories they were blended with the gum of a third tree - the exotic *Palaquium gutta* from the Malay peninsula - to form Chatterton's compound. This truly international product, the first steps toward synthetic plastics, revolutionised the submarine cable industry allowing the tendrils of Empire to snake around globe. When people refer to London as the 'melting pot' of the world, it is easy to imagine that pot to be full of Chatterton's compound.

1. S. Roberts, *Distant Writing: A History of the Telegraph Companies in Britain between 1838 and 1868* (2006), p.128, <http://distantwriting.co.uk> (consulted 3 September 2016).
2. W. E. Ayrton, *Preliminary catalogue of the apparatus in the Telegraph Museum* (Bristol: Bristol Selected Pamphlets, 1877), p. 14.
3. J. Munro, *Nerves of The World*, (unknown publisher, 1895), transcribed by B. Glover, (2008) <http://tinyurl.com/zq25lv4> (consulted 3 September 2016).
4. Ayrton, *Preliminary Catalogue* (1877), p. 14.
5. R. Outland, *Tapping the pines: the naval stores industry in the American South* (Louisiana State Univesity Press, 2004), p. 9.,
6. T. Gamble, 'How The Famous "Stockholm Tar" of Centuries of Renown Is Made' (1914), in T. *Gamble Naval Stores: History, Production, Distribution and Consumption* (Savannah, Georgia: Review Publishing & Printing Company, 1921), pp. 46-7.
7. T. P. Kaye, 'Pine Tar; History And Uses', *Third International Conference on the Technical Aspects of the Preservation of Historic Vessels* (San Francisco: San Francisco Maritime National Park Association, 1997), p. 1.
8. Gamble, *Naval Stores* (1921), p. 46.
9. N. E. Villstrand, 'Skogen, Bonden och Tjran' (2003, updated 2007), <http://tinyurl.com/h4h3ubp> (consulted 3 September 2016).
10. B Hjulstrom, 'Organic Geochemical Analysis for pine tar production in middle Eastern Sweden during the Roman Iron Age', *Journal of Archaeological Science*, vol. 33 (2006), pp. 284-6.
11. Outland, *Tapping the Pines* (2004), p. 267.
12. Ibid., p.14.
13. J. G. Randall & D. Donald, *Civil War and Reconstruction* (Lexington: D C Heath & Co., 1961), p. 68.
14. F. L. Olmsted, *A journey in the seaboard slave states: with remarks on their economy* (New York: Dix & Edwards, 1856), p. 338.
15. Outland, *Tapping the Pines* (2004), p.127.
16. Ibid., p. 75.
17. Ibid., p. 77.
18. T. Gamble, 'The World Wide Consupion of Naval Stores', in Gamble, *Naval Stores* (1921), pp. 91-95.

CATALOGUE ENTRY D1 | DISTANCE

JAMES CLARKE HOOK (1819–1907)

# WORDS FROM THE MISSING, 1877

78 X 130 cm

GUILDHALL ART GALLERY, CITY OF LONDON CORPORATION



In many ways this painting is an analogue to Albert Goodwin's *The Toiler's Return* (Cat. D15); both appeared in the 1877 Royal Academy Summer Exhibition (nos. 126 and 1329). It shows the same generous sweep of beach and cliff on the right, and the grouping of mother, son and daughter is similar; only the baby is missing. But the threat hanging over Goodwin's figures has been visited on this family, and they have given up looking out for the returning boat. Their poverty is conveyed by the woman's stooped pose as she collects driftwood on the beach; the children play barefoot in the surf, they have set aside a toy boat. Seeing a slip of paper in a bottle washed up on the shore, they imagine that it might hold a message from their lost father.

The vivid light on the clouds, the moving waves and the figures' vibrant forms, with careful rendering of details such as hands, all offer a sense of presence and immediacy. The specificity of these insignificant, ephemeral lives is juxtaposed with the steady, impersonal power of the sea and the unyielding rock of the shoreline. The emphasis on environment and observation, blended with a hint of narrative, allows the viewer some freedom of interpretation. At least one contemporary critic read a lighter story into the image: 'A poor fisher-girl has come to the beach to gather drift-wood; and her little brother playing about, and, boy-like, looking for what flotsam and jetsam in his small way the sea may have cast up, has come upon a bottle, which has evidently been some time in the water, for a piece of seaweed has grown to it. He holds his prize up to the wondering eyes of his little sister, who stoops ... that she may more readily catch a proper sight of the paper that is within, and which contains the "word from the missing"'<sup>1</sup>

This fluidity of meaning is doubtless part of the painting's appeal, one that may have been intrinsically modern. Telegraphy, with its requirements for abbreviation and coding, had enhanced the recipient's role in understanding a message. In this painting, the apparently conflicting emotional cues of the children's playfulness and the bright sunlight alongside the woman's stooped form and the portentous title intentionally offer the potential for a range of interpretations. Similarly, the romantic serendipity of a message washed up like treasure among the driftwood is perhaps especially compelling in a technological era where miracles of distance are an issue, paradoxically, of calculation and precise engineering.

Hook's vivid treatment of the various pictorial elements elicited much praise, with the sea judged 'excellently liquid', and the painting offering 'a crispness and a smack of Nature in the rough'.<sup>2</sup> Another reviewer appreciated 'the intentness of the little girl'.<sup>3</sup> Most notable for the purpose of this exhibition though, was a long and lyrical review that builds to a eulogy on distance: 'A lime-kiln, grey-lichened like a rock, is in a niche in the mid-distance, nestled under the cliff; beyond is trembling, greyish colour on the sea, half light, half vapour. *The distance is most exquisite.* A waft of smoke trailing near the horizon tells of a steamer there. Far beyond that is a faint, undefined whitish lustre: cliff or cloud, who can tell? The picture is gloriously full of pure silvery light, dashed with subtle grey tones of shadow'.<sup>4</sup>

Hook had trained at the Royal Academy, becoming an Associate in 1850 and a member in 1860. He worked in a range of genres, but was particularly associated with seaside subjects; in 1877 he submitted two other paintings to the Royal Academy, *The Gull Catcher* (no. 182) and *Friends in Rough Weather* (no. 380).

NH

1. 'The Royal Academy Exhibition', *Art Journal* (July 1877), p. 198.

2. The Royal Academy: III', *Saturday Review of Politics, Science and Art* (19 May 1877), p. 614; W. H. Combes, 'Royal Academy Exhibition of 1877', *Tinsley's Magazine*, vol. 20 (June 1877), p. 588.

3. 'The Royal Academy: III', *Saturday Review*, p. 614.

4. *Athenaeum* (5 May 1877), p. 582, [emphasis added].

CATALOGUE ENTRY D2 | DISTANCE

WILLIAM LIONEL WYLLIE (1851 – 1931)

# COMMERCE AND SEA POWER, 1897

91 X 152 cm

GUILDHALL ART GALLERY, CITY OF LONDON CORPORATION



Vessels with diverse functions share the same waters in William Lionel Wyllie's painting of the busy Thames. On the left sailing barges, sailing ships and steam ships engage in commerce, on the right the freshly-launched battleship *HMS Illustrious* is bound for fitting-out in the dockyards at Chatham. Suggesting the extent of marine technology's influence, Wyllie connects spectators to this bustling activity by placing them within the scene: in the foreground the wake of another, unseen, vessel spreads and disrupts the surface, a vessel from which we seem to observe the other ships. *Commerce and Sea Power* further suggests this extensive influence in that the horizon is lost in the indistinguishable blurring of what could be either masts at sea or industrial buildings on land; smoke and steam rise from and disguise both. Wyllie's picture alerts us to the close relationship between imperial trade and naval power in the late Victorian period. In Britain the telegraph first commenced and then grew as a commercial, potentially profit-making enterprise, but in the 1840s it was the construction of a line for the Admiralty that signaled its acceptance as a reliable means of communication.<sup>1</sup> Telegraphic messaging systems provided vital support for trade and for military prowess.

*Commerce and Sea Power* is one of many depictions of the Thames by Wyllie amongst a career focused on the sea. The *Art Journal's* review of the painting looks back to Wyllie's popular work on a similar theme, *Toil, Glitter, Grime, and Wealth*, which had been exhibited fifteen years earlier to great acclaim, described in the same magazine as 'remarkable'.<sup>2</sup> In the earlier work, Wyllie draws the viewer's attention to the human labour involved in the working life of London's great river; here in *Commerce and Sea Power* he focuses

on the vessels themselves, the technological machinery of empire, rather than the people operating it.

As well as painting marine scenes extensively, Wyllie also worked for many years as an illustrator of those subjects for the weekly periodical *The Graphic*. Wyllie himself had both naval and commercial interests in the sea; he worked for the White Star shipping line and he became increasingly involved with the Royal Navy in later life, sailing with the fleet during the First World War in order to make drawings. He was also a founder member of the Society for Nautical Research, campaigning for *HMS Victory's* restoration at Portsmouth.

Wyllie began exhibiting at the Royal Academy in 1868 and this picture was shown there thirty years later (no. 210). At the same exhibition he showed four other pictures including *The harbour bar* (no. 883) and *Entrance to Barry Dock* (no. 886). Wyllie was elected to be ARA in 1889, RA in 1907, and RSA in 1927. The Corporation of the City of London holds a number of Wyllie's works. London Metropolitan Archives have some of his etchings of the Thames, and the Guildhall Art Gallery's collection includes two other of his paintings: *Scene on the Lower Thames* (1884) (which can be viewed in the Resistance section of *Victorians Decoded*), and *The Opening of Tower Bridge* (1894-5).

AC

1. For a more detailed discussion of this and the further commercial development of the telegraph in Britain see section 7.2 of Robert Wenzlhuemer, *Connecting the Nineteenth-Century World: The Telegraph and Globalization* (Cambridge: Cambridge University Press, 2013), pp. 168-176.

2. 'The Royal Academy, 1898', *Art Journal* (1898), p. 177; J. Penderel-Brodhurst, 'The Newest Associate of the Royal Academy', *Art Journal* (1889), p. 223.



CATALOGUE ENTRY D3 | DISTANCE

JOHN ATKINSON GRIMSHAW (1836–1893)

# THAMES BY MOONLIGHT WITH SOUTHWARK BRIDGE, LONDON, 1884

75 X 127 cm

GUILDHALL ART GALLERY, CITY OF LONDON CORPORATION



This painting depicts the Thames from the South Bank just east of Southwark Bridge, looking west towards St Paul's Cathedral. A line of gaslights illuminates the city, which is otherwise shadowy and dark, but the river and sky are radiant with moonlight. The river is scattered with Thames sailing barges, which were important for goods transport; their sails are furled for the night creating a characteristic profile against the night sky. There are no distinct human figures, despite the sophisticated built environment and the street lighting.

The sky and river recede into the pictorial space, shining, rippling and paved with clouds, like a superhighway. The light of the moon is compared with the glowing points of gaslight, making a connection between cosmic energy and industrial lighting. The use of electricity was growing rapidly during this period, not least for lighting, as arc street-lighting spread through London and other industrial towns. Electric lights are not shown here, but they appear in other Grimshaw paintings, such as *Reflections on the Thames: Westminster* (1880, Leeds Museums and Galleries).

Telegraphy was by now well established throughout the British Empire: the way the moonlight pours down the river provides an image for the vast tracts of land and sea that were laid with telegraph cables, making the globe a vast, interconnected network. The distant moon, bringing light into this setting, is a reminder that electricity was a natural phenomenon. Furthermore it evokes the planetary scale of the imperial telegraphic project. There is an extensive rhythm of uprights across the painting, formed by the dark

posts in the foreground and reiterated by the furled sails, the towers and dome of St Paul's and the vertical stripes of light reflected on the water. This is counterbalanced by patterns of cloud and ripples in the sky and river suggesting pictorial depth and recession. Despite the overwhelming stillness of the picture, there is an implicit sense of flow in each individual element, from the bridge and the river to the clouds and the gaslights.

Grimshaw, who grew up in the north of England, was largely self-taught. His early landscapes are often considered to show Pre-Raphaelite influence, and it is thought that both theatre and photography had an impact on his aesthetic.<sup>1</sup> J. A. M. Whistler, a neighbour during the period when Grimshaw lived in Chelsea when this painting was made, is rumoured to have 'declared that he had thought he had invented pictorial "nocturnes" until he saw Grimshaw's moonlight pictures'.<sup>2</sup> Grimshaw worked prolifically, particularly during the 1880s while he was living in London. The majority of his work depicts moonlit landscapes but he also painted mythic or fantasy subjects (such as *Iris, Goddess of the Rainbow*, 1886, Peter Nahum) and brightly pigmented domestic scenes reminiscent of the work of James Tissot (such as *Dulce Domum*, exhibited at the Royal Academy Summer Exhibition of 1885, private collection).

Despite representation by the prominent gallery Arthur Tooth and Sons and respectable commercial success, Grimshaw only ever exhibited five pictures at the Royal Academy, and received little press attention: an *Athenaeum* article written in the prime of the artist's career and entitled 'The Private Collections of England' notes that 'A picture by Mr. Grimshaw, whose name is unknown to us, renders with acceptable tact tree shadows in moonlight, barring the long vista of a level road'.<sup>3</sup> Much of Grimshaw's work remains in private collections.

NH

1. See Frank Milner, 'The Mystery of the Self-Taught Pre-Raphaelite', in Jane Sellars (ed.), *Atkinson Grimshaw: Painter of Moonlight* (London: Mercer Art Gallery and Guildhall Art Gallery, 2011).

2. Guy Ragland Phillips, unpublished memoir, quoted in Mark Bills, 'Atkinson Grimshaw in London', in Sellars, *Atkinson Grimshaw* (2011), p. 76.

3. 'The Private Collections of England', *Athenaeum* (13 September 1884), p. 341.

CATALOGUE ENTRY D4 | DISTANCE

WALTER GREAVES (1846–1930)

# THE POOL OF LONDON, C.1863–1869

61 X 102 cm

GUILDHALL ART GALLERY, CITY OF LONDON CORPORATION



Walter Greaves, whose father was a boat-builder, painted many pictures of the Thames at night. This one depicts the stretch just east of London Bridge, where the river opens out. The foreground expanse of flat open water is juxtaposed with the dense city arrayed along the opposite bank, forming a thick, straight, high horizon. This effect, combined with the powerful horizontal emphasis of the picture, produces an unusual, unsettling perspective, and the water seems to shift and tilt, producing a queasy floating sense of disorientation. Dark boats are silhouetted against the soupy water.

The limited, greenish palette suggests a murky underwater world: the same tonal effect is used for sky, river and glowing lamps, so that air, water and light all share the same opaque luminescence. The closely packed, straight line of buildings is soft and smudgy: details are indistinct but the roofline is composed of protuberances, such as chimneys and gables. The masts of the boats participate and punctuate this uneven rhythm, producing a skyline that resembles a ticker tape read-out. This effect is reproduced in the pattern created by the grids of black windows on the row of buildings. The first telegraphic stock price ticker systems were being developed during the years this painting was made, with Thomas Edison patenting the Universal Stock Ticker, which could print about a character per second, in 1869.<sup>1</sup> The trading of stocks is a metaphor for the correspondence between the passage of material things and the transmission of messages and signals.

The river was essential as a conduit for the transport of goods through industrial London. A strong lateral pull seems to stretch the image, emphasised by the continuation of all

elements across the right and left edges of the picture. The river itself is described by layered lateral brushstrokes, underlining the flow across the pictorial plane. The boats, in particular, are cut off at each side; the one on the left, which contains a human figure, has just been moored but the current is pulling it away from the centre of the picture. The diagonal of the mooring rope is answered by the one created by the little fleet of boats on the right, which both recede into the depth of the picture and stretch across it, creating a sense of space in both directions.

Walter Greaves was knowledgeable about boats and spent his life on the Thames; his father was a boat-builder who had taken J. W. M. Turner out on the river. Walter had received no formal training but he and his brother Henry had both worked as assistants to J. A. M. Whistler; their own work received very little attention during their mentor's lifetime. When a painting by Henry was included in a Dudley Gallery exhibition alongside one of Whistler's, much of the commentary was negative, with one reviewer labelling him 'the ghost of a ghost and a shadow of a shadow'.<sup>2</sup> The controversy was more intense when Walter Greaves received his own exhibition at the Goupil Gallery in 1911, some years after Whistler's death. Some critics hailed him as 'a newly discovered master' or wondered 'that Whistler never did anything to bring to him the fame which he must have known was his due'; others were dismissive.<sup>3</sup> One particularly cruel attack judged him 'artistically speaking, deaf and dumb and blind', going on to end with the hypothesis that 'if Whistler were to come to life again I am sure he would kill Greaves. Any sensible jury would acquit him if he did'.<sup>4</sup> Walter Greaves remains very much in the shadow of Whistler's reputation.

NH

1. Edison's patent had a range of less commercial predecessors going back to the 1850s. See [https://en.wikipedia.org/wiki/Ticker\\_tape](https://en.wikipedia.org/wiki/Ticker_tape) (consulted 2 September 2016).

2. 'Dudley Gallery', *Illustrated Review: A Fortnightly Journal of Literature, Science and Art*, vol. 6, no. 98 (November 1873), p. 380.

3. 'By the Newly Discovered Master: Works by Walter Greaves', *Illustrated London News* (13 May 1911), p. 691. 'Pictures by Walter Greaves Reveal the Tragedy of Art', *Chicago Tribune* (7 May 1911), p. 6.

4. R. Strong, 'The Greaves Humbug', *Saturday Review of Politics, Literature, Science and Art* (3 June 1911), pp. 675–676.

CATALOGUE ENTRY D5 | DISTANCE

JOHN BRETT (1831 – 1902)

# *ECHOES OF A FAR-OFF STORM, 1890*

107 X 213 cm

GUILDHALL ART GALLERY, CITY OF LONDON CORPORATION



This painting, suffused with atmospheric golden light, depicts unsettled weather on the Cornish coast. The turbulence, denoted by dark clouds and a rough sea, is in the distance; the foreground is tranquil in comparison, but the pooled water ripples gently in response to remote currents. The canvas is divided vertically into three layers, with the middle section, of sea and low cloud, showing the direct effects of the storm; the lower and upper layers, comprising a sandy beach with pooled water and a blue sky with sparse, high cloud, show a faint response to the energy evident in the middle section.

Each section merges with the others, in material and colour as well as form: water pools into hollows in the foreground and crashes against the distant rocks, splashing into the sky. The golden sand corresponds to the yellow light in the sky, and the sea reflects purplish storm clouds, also picked up in the dark rocks. In form, the picture is composed of a series of echoes: ripples in the pooling water are answered by the impressions they have made in the sand; the scalloped edges of the pool echo the creviced edges of the rocky outcrops; and the persistent waves on the sea rhyme with the low-hanging cloud in the sky. A flock of birds on the sand reprises the small group of gulls on the left of the picture.

The result of these slippages and repetitions is a disorientating pictorial space, a landscape that is as abstract as it is representational. The palette is unexpected for a British landscape, its heat and saturation echoing colours that were often used to depict the Middle East, although such unorthodox colours were typical of Brett.<sup>1</sup> As with so many of the paintings in the Distance room, there are no human figures, but the painting's title suggests the scene is being witnessed. There is a distinct sense of temporality: an echo is ephemeral, a sound that passes through time as well as space. Ripples, waves and clouds are equally

transient; even the rocks and sand are manifestations of years of weather.

In portraying rhythmic and repetitive forms of light, sound and motion in nature, Brett explores phenomena that had made enormous impacts upon post-industrial society. The telegraph, though still in constant use, was no longer cutting-edge technology when this painting was made; modern society was fully acclimatised to the significance of energy waves, pulses and patterns. By 1890, when the first ‘phonograph parlor’ opened in San Francisco, the potential of technologies that reproduced electrical signals as sound had become apparent; the telephone was already widespread, and the Gramophone had been patented in 1887. Pictorially, a distant storm, in which a series of electrical discharges are experienced first through sight and then through sound, was a perfect representation of these technological and commercial trends.

This picture was exhibited at the Royal Academy in the 1890 Summer Exhibition, along with three others. Their avant-garde approach was not particularly successful among commentators. One wrote that the ‘three “Cornish Sketches” (430-2), ... reveal much of [Brett’s] power in seizing optical effects of light on sea and rocks, but ... are not the more attractive because, as the artist assures us, they are “one-sitting sketches not retouched”’.<sup>2</sup> Brett’s emphasis on pattern, repetition and persistence – elucidated by the title – seems lost on the *Illustrated London News* critic, who complained, apparently without irony, that *Echoes* was ‘too suggestive of shore scenes already painted by him’.<sup>3</sup> Such comments suggest that Brett, along with two colleagues, were justified in being ‘chief ... Academic inveighers against the art-critic’.<sup>4</sup>

As a young painter, Brett had been associated with the Pre-Raphaelite movement; he focused on landscapes throughout his career, and was a keen astronomer. In 1890, Brett was elected Master of the Art Workers’ Guild, a society of which he had been a founding member.

NH

1. The combination of orange and purple is particularly reminiscent of William Holman Hunt’s very famous mid-century picture *The Scapegoat*, of which significant portions were painted in plain air at the Dead Sea (two versions, 1854–6, Lady Lever Art Gallery, Port Sunlight and Manchester Art Gallery).

2. ‘Art Exhibitions’, *Illustrated London News* (5 July 1890), p. 24.

3. ‘The Royal Academy’ *Illustrated London News* (17 May 1890), p.619.

4. The other ‘inveighers’ were Professor Richmond and Mr. Frith. M. H. Spielmann, ‘Glimpses of Artist-Life: VIII’, *Magazine of Art* (January 1890), p. 120.

CATALOGUE ENTRY D6 | DISTANCE

HENRY MOORE (1831–1895)

# THE WRECK, 1875

43 X 66 cm

GUILDHALL ART GALLERY, CITY OF LONDON CORPORATION



This painting shows a wide sea under a stormy sky, all suffused with a strange, atmospheric light. The location must be coastal, as signified by the breaking waves, but no land is in sight. A skeletal wreck lies in the middle distance near the horizon; sea spray is showering through its punctured form. Sea and sky mirror one another, appearing to stretch away in all directions; the wideness of these expanses is enhanced by their formation of uninterrupted borders at the top and bottom of the canvas. The wreck interrupts this all-over pattern, answered by a break in the clouds above to create a kind of diagonal symmetry, the dark form of the wreck balanced by the bright blue of the sky. The result is a composition that appears wild and natural, but relies on an underlying mathematical structure.

The boat and its environment embody interactions between knowledge and the natural world, visualised here as pattern and disorder. Such relationships resonated with recent developments in science and technology, particularly in a marine context. Electricity was a natural phenomenon that had been harnessed and was being put to a rapidly expanding range of uses, and the waveform was central to electricity, particularly since the development of alternating-current systems. Telegraphic signals were transmitted as shaped pulses of current which syphon machines recorded as waveforms, enhancing the knowledge that a varying series of waves could encode complex information. The perforated form of the boat, through which the water washes, manifests the permeability and perhaps predicts the obsolescence of matter in a world where long-distance communication was becoming liberated from paper and ink, to emerge as energy pulses conducted through telegraph

or telephone. The waves break rhythmically but not evenly, as though beating out a message, while rolling clouds answer the pattern.

Physicists were also investigating thermodynamic entropy, a principle that was based on the idea that energy was subject to transformation and was not an indestructible particle that had mass. Entropy considers the dissipation of energy as it transforms from one type to another in any physical process.<sup>1</sup> The sea offers an interesting illustration of the subject: it derives its energy directly from the sun and the weather, creating a continuous, cyclical pattern of energy transfer (the tide goes in and out and one wave is followed by another, despite variations in magnitude). The motion of the sea, in turn, enacts a particularly destructive and uncontrollable form of entropy, as exemplified by the wrecked boat.

The sea also symbolised the British imperial project, driven by naval technology and, by the 1870s, reliant on submarine telegraphy. Given the associations between naval power and British expansion, the choice of a wrecked vessel as the subject of this painting seems significant. There was considerable dissension about Britain's commitment to an aggressive foreign policy, not only because of the brutality it involved but also because of the resources it consumed. Moore's wreck is so dark and broken by the motion of the sea that its original form has been obliterated. But the spray of seawater emerging from the old hull and cascading through the air resembles the spout of a whale, a sign of respiration, suggesting an oblique return to associations with nature, rhythm and renewal, as well as scale.

In terms of subject matter and its coastal location, this is a slightly more conventional painting than Moore's later work *Summer Breeze on the Channel* (1893), also in this section of the exhibition. Its limited palette and close attention to the effects of cloud and water are striking indications of the direction Moore would take with his work over the coming decades, as he became ever more immersed in the abstractions of rhythm and light in a marine context.

NH

1. A good and straightforward description can be found here: <http://tinyurl.com/j7dfam1> (consulted 17 September 2016).



CATALOGUE ENTRY D7 | DISTANCE

JAMES CLARKE HOOK (1819 – 1907)

# *DEEP SEA FISHING, 1864*

84 X 61 cm

GUILDHALL ART GALLERY, CITY OF LONDON CORPORATION



Alongside all the portrayals of space and distance in this section of the exhibition, this painting evokes a startling sense of proximity. It depicts three fishermen trailing lines from their moving boat. The weather-beaten faces on the right resemble one another, implying that this is a family enterprise: the central fisherman might be the father of the others. Despite the collaborative nature of their work, each man seems lost in his thoughts as he gazes along his line, held with a steady, practised hand.

The unusual portrait format and composition has the viewer occupy the water, peering upwards, like a fish, along the trailing lines into the men's faces. The boat's painted wooden boards are dramatically foreshortened and vividly tactile; the vessel fills and overlaps the canvas on the upper three sides, emphasising the sense of distance below. The swirling green water is rendered with a textured build-up of paint that shifts between transparency and opacity, conveying both depth and movement. In contrast, the sky above the boat is soft and even, a heavy curtain of diffuse cloud.

The harmonious palette suggests that these figures are familiar with their environment: the boat's hull is painted in a watery blue, but the tanned sail picks up the warmth of the men's faces. The boat's robust solidity is in contrast with the wild, insubstantial water. This maps a relationship between the accurate measurement of physical distance, marked by solid increments, and the abstract notion of distance, watery with slippage and relativity. Distance is also conveyed in potential terms, introducing tension and drama: the splashing water and dragging lines show that the boat is moving quite rapidly away from the picture plane, so the distance between the viewer and the subject is always on the verge of increasing.

The trailing of lines from the boat mimics on a diminutive scale the industrial operation of laying submarine cables. By 1864 this had been achieved across the English Channel and attempted four times over the much wider expanse of the Atlantic, where the stable connection would be made in 1866. The painting emphasises the transition between air and sea: both submarine telegraph cables and fishing lines passed through an underwater world, alien and inaccessible from the air. Similarly, telegraphic signals passed from text to code (transmitted in the form of electrical pulses), then back again. For the consumer, the raw electrical pulses are alien and unintelligible; they must be transformed or tamed before receipt. For the fishermen, the lines perform a primitive form of contact signalling, as they wait to feel a bite from below the water. Telegraphic signalling also relied on dexterity, with operators becoming highly skilled and deft in tapping out codes using a telegraph key (experienced operators could recognise one another from their distinctive tapping styles).

This was a prolific period for Hook; although he did not submit this painting to the Royal Academy he showed five others there that year, including *From Under the Sea*, which received positive attention. Deep-Sea Fishing was included, however, in a posthumous show at the Winter Exhibition of the Royal Academy in 1908. An admiring reviewer comments, ‘As the inscription on the sturdy, picturesque boat makes clear, “Deep Sea Fishing” is one of many vigorous reminiscences of life on the Cornish coast’. Since Hook travelled frequently to coastal locations during the 1860s, ‘reminiscences’ presumably refers to the technique of working up *plein-air* sketches in the studio, or perhaps to the age of the painting. The reviewer goes on to establish the late artist’s status as a longstanding Royal Academician: ‘Until he retired a year ago, Mr. Hook was the Father of the Academy, inasmuch as he had been one of the “Faultless Forty” since 1860, nine years longer than Mr. Sant, sixteen than Mr. Leslie’.<sup>1</sup>

NH

1. ‘Passing Events’, *Art Journal* (February 1908), p. 58.

CATALOGUE ENTRY D8 | DISTANCE

HENRY MOORE (1831–1895)

# *SUMMER BREEZE IN THE CHANNEL, 1893*

61 X 101.5 cm

ROYAL ACADEMY OF ARTS



This astonishing, strikingly modern painting was Moore's diploma submission on becoming a member of the Royal Academy, where it has remained ever since. It shows two ships far away on an otherwise uninterrupted ocean. Moore's assured technique encompasses a range of brushwork, from dense, tossing waves to the loose impressionism of the clouds to the finely blended hazy line of the horizon. The effects of aerial perspective, which make far-away objects appear blue, are both explored and undermined by the pervasive blueness of the whole scene. The patterns of waveforms echo the rolling clouds in the sky, but the weight of the water on each crest is viscerally described, so that the behaviour of each element – water and air – is quite distinct.

Moore refined his subject matter to produce full-scale paintings that were effectively studies of sky and waves, an approach contemporaries recognised as new and progressive. The way the distant ships harmonise and merge with powerfully atmospheric surroundings emphasises that phenomenology and the environment – not the vessels – comprise the subject of the picture. In 'A Modern Marine Painter' of 1890, critic P. G. Hamerton elaborates on the artist's revolutionary style, declaring him thoroughly modern 'in his separation from all marine painters who have preceded our own times', 'distinctly severed from the past'.<sup>1</sup>

Despite the overwhelming predominance of blue, the palette is warm and varied. Many new artificial pigments became available during the late nineteenth century, including a wide range of intense blues, which were paradoxically often used to depict the natural world (in

Pre-Raphaelite and Impressionist work, for example). The modern look of Moore's work suggests that he may have made use of this expanded tonal range. Critics dubbed his style '*note bleue*', a term that described his prevailing palette, connected him with Whistler's fashionable musical references and also signified Moore's popularity on the Continent, particularly among French painters and critics.<sup>2</sup>

Hamerton notices 'that he ventures upon the true blue reflected from the sky'.<sup>3</sup> There had been considerable scientific interest in optical blueness during recent decades, exemplified by John Tyndall's famous 1869 investigations. This work was developed by James Clerk Maxwell, whose 'Tyndallic Ode' offered a humorous, lyrical commentary:

What gleams are these of heavenly blue?  
 What air-drawn form appearing,  
 What mystic fish, that, ghostlike, through  
 The empty space is steering?<sup>4</sup>

This poem, and John Ruskin's uneasy description of Tyndall's experiment as 'putting the sky in a bottle', not only made oblique reference both to vastness and miniaturisation, but also indicated the way that such research went to the very heart of questions about religion, nature and humanity's place in the world.<sup>5</sup> Towards the end of the century, such preoccupations intensified as the apparently ghostly and spectacular technology of early cinema emerged alongside the rise of spiritualism as belief, practice and entertainment.<sup>6</sup>

There is something otherworldly about *Summer Breeze*, with its perfect, unpeopled ships – ghostlike or illusory, like *The Flying Dutchman* – in the distance. It was its ethos of spectacular detachment, as much as the palette and the subject matter, which was so absolutely of its time. An exchange between Moore and Hamerton demonstrates tension around the pervasiveness of technology, with the artist responding defensively to the critic's suggestion that instantaneous photography must have aided his study of waveform, insisting 'all his pictures ... are either direct from nature or painted from his own studies made at sea'. Hamerton would not fully accept Moore's position, reiterating that 'It seems impossible that any artist who observes transient phenomena can have failed in these days to gain some knowledge from instantaneous photographs'.<sup>7</sup>

Distance was evidently a persistent subject. An 1887 review of Moore's *Clearness After the Rain* could equally be applied to *Summer Breeze*. It describes 'an ever-shifting wilderness of blues, clear, opaque, and semi-transparent as the light allows... The vastness and loneliness of the "waste of waters wide and deep" are emphasized by the few sails which, separated from each other by leagues of sea, pass on the horizon'.<sup>8</sup>

1. P. G. Hamerton, 'A Modern Marine Painter', *The Portfolio: An Artistic Periodical*, vol. 21 (January 1890), p. 88.
2. 'Mr. Henry Moore ... contributes three magnificent examples of his finest work – all of them in his favourite note bleue ... one ... is almost too blue for nature ... as studies of sea and sky they probably equal anything the English school can show'. Editor, 'The Royal Academy Exhibition: II', *Magazine of Art* (January 1893), p. 256. Another critic notes that 'his reputation is European ... and has been greatly honoured at Paris and other Art centres.' 'The Royal Academy Elections', *Art Journal* (June 1893), p. 192. During his career, Moore received a Médaille d'honneur and was made a Chevalier of the Légion d'honneur.
3. Hamerton, 'A Modern Marine Painter' (1880), p. 88.
4. Tyndall presented his experiment at the Royal Institution, 15 January 1869, to accompany his lecture 'On Chemical Rays of the Light of the Sky'. James Clerk Maxwell wrote his 'Ode' in 1871. For more on this, see D. Brown, *The Poetry of Victorian Scientists: Style, Science and Nonsense* (Cambridge: Cambridge University Press, 2015).
5. '... I'll thank them the men of science – and so will a wiser future world – if they'll return to old magic – and – let the sky out of the bottle again, and cork the devil, in'. J. Ruskin, letter to Charles Eliot Norton, 1 May 1869, J. L. Bradley and I. Ousby (eds.), *Correspondence of John Ruskin and Charles Eliot Norton, (1987)* (Cambridge: Cambridge University Press, 2011), p. 135.
6. See, for example, S. Natale, *Supernatural Entertainments: Victorian Spiritualism and Media Culture* (University Park, PA: Penn State University Press, 2006).
7. P. G. Hamerton, 'Mr. Henry Moore's Marine Pictures', *The Portfolio: An Artistic Periodical*, vol. 21 (January 1890), p. 110.
8. 'The Royal Academy', *Athenaeum* (11 June 1887), p. 773.

CATALOGUE ENTRY D9 | DISTANCE

WILLIAM AYERST INGRAM (1855 – 1913)

## *EVENING*, 1898

104 X 182 cm

GUILDHALL ART GALLERY, CITY OF LONDON CORPORATION



The pink-tinged clouds are lit from below as sunset occurs, giving them sculptural form. Golden-hued sky stretches across the broad horizon. The clear atmosphere allows the viewer to see for miles. The water heaves and shifts, throwing up mountainous forms, heavily shadowed on our side. Ingram uses one far-off sail to indicate the immense scale of the scene. The soothing warm light from the distant horizon is countered by the chilly, gloomy bulk of intervening waves.

This picture was exhibited at the RA in 1898 (no. 30). At the same exhibition Ingram showed two other pictures: *Derelict* (no. 536) and *A breezy day* (no. 562). The *Athenaeum* reviewed the picture, finding the treatment of the water better than the clouds: “Evening” (30); where the surface of an opaque sea is excellently treated, is fresh, and if the clouds were less painty it would be thoroughly welcome.<sup>1</sup> The work was also shown to an East End public at the South Londondon Art Gallery in 1899.<sup>2</sup> Some critics found his colour and light effects to be overdone on occasion. He could produce work that was ‘luminous in tone’ or else ‘rather lurid and opaque’.<sup>3</sup> The composition of *Evening* can be compared to *Schooner On the High Seas* (Falmouth Art Gallery, n. d.).<sup>4</sup>

Ingram, an artist with a base in Newlyn, and later Falmouth, and a studio in Chelsea, was known as a traveller to distant spots of the globe through his exhibition of marine landscapes, oils, watercolours and sketches relating to his travels particularly to Australia. He was often bracketed with Henry Moore as a specialist in painting the sea. Two pictures by Moore are included in this section of the exhibition. Indeed the *Saturday Review*

speculated that ‘Mr. Ingram must be tired of hearing that some of his work resembles Mr. Moore’, going on to emphasise their shared merits. In both cases their work was said to be based on careful observation: ‘both have been so lucky, or so observant, as to perceive some peculiarities in the forms of waves, billows or rollers which, while they are eminently difficult to draw, are well worth the attempt’.<sup>5</sup> Observation, or ‘fidelity’, was often the keynote of critics’ responses to his work; a lack of exaggeration and broad treatment avoiding finicky detail were appreciated.<sup>6</sup>

Ingram was elected to be a member of the Society of British Artists in 1883. He was also founder of the Anglo-Australian Society of Artists, and its President in 1888. The society was instrumental in bringing the work of British artists to Australia.<sup>7</sup> A journal item of 1889 about the Anglo-Australian Artists exhibition (superintended by Ingram) at the National Gallery in Sydney (also travelling to Melbourne and Adelaide) mentioned the inclusion of twenty etchings by Ingram’s friend J. A. M. Whistler as well as works by a number of artists featured in *Victorians Decoded: Art and Telegraphy*: G. F. Watts, F. Leighton, W. L. Wyllie and S. J. Solomon.<sup>8</sup> It is interesting to think that the waves, billows and rollers in his pictures represent the distance across which (at his instigation) artworks were physically transported.

CA

1. *Athenaeum* (18 June 1898), p. 797.

2. Information from object file, Guildhall Art Gallery.

3. *Graphic* (18 Dec 1886), p. 651.

4. See Falmouth Art Gallery website for detailed biography and reproduction of this work, <http://tinyurl.com/h7vfd6z> (consulted 11 Sep 2016).

5. *Saturday Review* (4 Feb 1893), p. 124.

6. ‘Mr. Ingram, it is evident, has long been a close observant of waves’, *The Field* (21 Feb 1885), p. 217; ‘“Cloud” represents with rare fidelity, a cloudy but luminous sky vividly reflected in the calm sea’, *Graphic* (18 Dec 1886), p. 651; ‘His methods are broad and straightforward’; ‘Mr. Ingram’s work is spontaneous and inevitable’, *Academy* (30 May 1914), p. 694 and p. 695.

7. ‘Art in October’ [re Oct 1889] p. iii, in ‘The Chronicle of Art’, *Magazine of Art* (January 1890).

8. *Academy* (26 Jan 1889), p. 64.



CATALOGUE ENTRY D10 | DISTANCE

JAMES HENRY NIXON (1802 – 1857)

# QUEEN VICTORIA'S PROCESSION TO THE GUILDHALL, 9 NOVEMBER 1837, 1838

142 X 173 cm

GUILDHALL ART GALLERY, CITY OF LONDON CORPORATION



This painting depicts the procession of Victoria's visit to lunch with the Mayor at the Guildhall. It was the young Queen's first public appearance since her accession on 20 June; she was only eighteen years old. The procession is passing the south side of St Paul's. The Guildhall Archive identifies key members of the procession: 'the Common Cryer carrying the City Mace and the Swordbearer wearing the fur cap. Behind them rides the Lord Mayor in his Coronation robes and bearing the Pearl Sword point upwards. Alongside the Lord Mayor walks a Beadle followed by the footmen in state liveries'.<sup>1</sup>

Nixon has chosen a viewpoint that looks back along the route, showing off the eight grey horses and the Queen herself, sitting inside the carriage, tiny amid the opulent surroundings. The palette makes a clear distinction between the scarlet flags and livery of the guardsmen, which stands out against the coats of the horses and the gold of the carriage, and the more modest browns and greys worn by the onlookers. The scene is dramatically lit, with sun bursting through grey clouds to fall upon the procession like a natural or divine blessing.

Victoria described the scene vividly in her journal, recounting her morning routine before continuing: 'Dressed for the Lord Mayor's dinner, in all my finery. At 2 I went in the state carriage and 8 horses ... Throughout my progress to the City, I met with the most gratifying, affectionate, hearty and brilliant reception from the greatest concourse of people I ever witnessed; the streets being immensely crowded as were also the windows, houses, churches, balconies, every where'.<sup>2</sup>

In distinction from many of the works in the Distance section of this exhibition, where distance is conveyed through a sense of disorientation and emptiness, the Nixon painting is anchored by specific landmarks and crowded with human figures. The rank of each member of the procession can be identified: the costumes act as a code to make the personnel legible. The members of the crowd are also differentiated, with a range of types and responses to the event. A matron stands earnestly in the foreground, gazing straight ahead, while a tall, dashing man at the front of the crowd plants his feet wide and stoops far over to get a better view of the spectacle. Many of the men have removed their hats as a sign of respect. On the far left a man holds a little girl up in the air, but she looks away from the procession, innocently indifferent, straight out of the painting.

The fluttering pennants lining the street animate the scene and suggest that there is a brisk breeze. This emphasises the idea of flow, implying that traffic, goods and information, just like the procession, will find a natural steady passage through the city's streets. At the same time, the picture is congested and busy: the orderly formation of the procession is compared to the almost anarchic multiplicity of the crowd, waving from every window and perching precariously on every ledge. The little dog in the foreground offers light diversion from the solemnity of the subject matter, but it also embodies a potential threat of chaos and congestion: it is positioned playfully, perpendicular to the direction of flow, its face irritatingly obscured by a large hat. This is one of the earliest paintings in this exhibition, produced in the early days of electrical telegraphy.

This painting was exhibited at the Royal Academy exhibition of 1838, where the catalogue announced that 'You would have thought the very windows spoke'. F. H. Nixon, the artist's son, sold the picture to the Guildhall in 1880.

NH

1. Object file, Guildhall Art Gallery Archive.

2. 'Journal Entry: Thursday 9 November 1837', Queen Victoria's Journals, vol. 4, p. 9. Available at <http://tinyurl.com/hw7d85p> (consulted 2 September 2016).

CATALOGUE ENTRY D11 | DISTANCE

JAMES BAKER PYNE (1800–1870)

# LAYING MONSTER TUBES FROM THE NEW RIVER, 1855

43 X 60 cm

GUILDHALL ART GALLERY, CITY OF LONDON CORPORATION



This is an unusual painting showing an improvement to London's infrastructure as it grew rapidly in the mid-nineteenth century. The scene, 'almost certainly in north London, most probably around Islington or Stoke Newington, or near the artist's home', which was in Camden Road.<sup>1</sup> Large cast-iron underground pipes (those in the foreground are probably terracotta) were used to modify the path of the New River, a seventeenth-century artificial waterway, and divert more water to the city. The lengths of pipework are scattered on the ground, alongside a deep trench that has been dug for them. Figures work along the route, leading away from the picture plane into the distance. A triangular structure holding a winch is shown in the middle distance; far beyond is a faint suggestion of the city's outline. The artist's signature is playfully foreshortened along the ground, stretching away alongside the trench, as though to establish the artist's work in dialogue with the labour represented in the picture.

The magnitude of the pipes is demonstrated by their position, allowing the viewer to see through them, and by their proximity to the human figures and horse. The figures' poses reveal the stress of hard labour: the man in red leans heavily on the harness, while the boy balances precariously on the edge of the trench. A resting figure on the right – a foreman or a worker on his break – offers a counterpoint to their discomfort. A large building

on the left, probably a public house, signifies the expansion of the built environment into the suburbs; a tree on the right stands for the natural landscape that was being edged out.<sup>2</sup>

The trench splitting the canvas illustrates a dichotomy at the heart of the subject matter. The progressive modernity that called for ambitious engineering projects was conceived in terms of efficient, frictionless flow: underground channels provided a conduit for water, sewage, gas and telegraphic messages; a year before this painting was made the Metropolitan Railway had been granted permission to build an underground train line. But the picture shows that this industrial revolution was powered by horses and, to a large extent, by human labour. The hard stones in the foreground are a reminder of this struggle, and the titular reference to ‘monster tubes’ hints at the grotesque scale of the project; it is easy to imagine the labourers referring to the great rounds of pipework in this way.

Distance is presented as work in this painting: each precisely cut section of cable embodies a certain amount of effort. The industrialised economy relied on efficient flow of goods and information over long distances; and the potential difference that sends current around a circuit – or electronic pulses through a telegraph cable – is rather like the pressure ensuring that water will flow through a plumbing system. In each case the magnitude of the signal or quantity of water has a relationship with the length and diameter of pipe or cable. The triangular structure holding the winch focuses the viewer’s eye on the distance the system had to traverse; but in contrast to the clear lengths of tube, this extent is uncertain in the milky light. Pyne was famous for his aerial perspective, a chromatic device that conveys a sense of distance and recession. One obituary reads, ‘His works were specially distinguished by pearly atmospheric colouring; his effects of light and air ... were founded on an ingenious theory of chromatic harmonies’.<sup>3</sup>

Pyne exhibited regularly at the Royal Academy, but this painting was shown at the British Society of Artists, where he had been a member since 1839 (and eventually became vice-president). One favourable review appreciates that ‘the geometrical forms are treated so cleverly, with the help of a little misty effect of light, as to render it a pleasing subject’.<sup>4</sup> There is a kind of ironic disingenuousness to the way this scene of industrial labour has been ‘rendered pleasing’ while losing none of its bite. Pyne’s interest in social matters is also in evidence in his dramatic 1830s series depicting the Bristol Riots.<sup>5</sup> Pyne travelled widely through Europe, and provided the pictures for a series of Lake District lithographs published by Agnew’s in 1853.

1. National Art Collections Fund Annual Review (1994). The Guildhall Art Gallery Archive notes state that 'in 1855 Pyne was living at 43 Camden Road'.
2. 'The building to the left is such a significant size and style that I have checked through our archives for possible identification. From its design I am inclined to say that it is a public house.' Letter, Mr D. Witney of Finsbury Library to Ms Knight, Corporation of London (10 May 1994).
3. 'The Late Mr. J. B. Pyne', Illustrated London News (20 August 1870), p. 193.
4. 'Fine Arts', The Lady's Newspaper (29 March 1856), p. 201.
5. Pyne was a native of Bristol and had studied under Francis Danby, an early member of the Bristol School. The Queen Square Riots of 1831 were a response to the Lords' rejection of the second Reform Bill, which would have given growing industrial towns including Bristol greater representation in the House of Commons.

CATALOGUE ENTRY D12 | DISTANCE

W. J. BAKER (1800–1870)

# POOL OF LONDON, 1892

50 X 69 cm

GUILDHALL ART GALLERY, CITY OF LONDON CORPORATION



This painting offers a highly congested depiction of the Pool of London, east of London Bridge, by day. A central thoroughfare leads into the depth of the picture, where the familiar profile of St Paul's can be seen in the distance. Crowds of ocean-going vessels throng the edges of the river, obscuring the shore, and the air is filled with smoke and steam, drifting up to blend with the thick grey banks of cloud. In the foreground, blackened men are working on barges loaded with coal.

A progressive tonal lightening leads into the picture, from the coal barges to the white stones of St Paul's, exaggerating the aerial perspective that helps to give a sense of depth. The palette reinforces the industrial subject matter: the blacks, greys and rusty reds are redolent of naval engineering and London skies, but also evoke the fiery furnaces that power the steam engines. Older vessels are arrayed alongside more modern boats, an anarchic accumulation of technology building up from both sides of the canvas.

This picture contrasts dramatically with the same subject painted by Walter Greaves. Abstract and dreamlike in comparison, Greaves's painting looks across the river rather than down it, and depicts shadowy, indistinct buildings and boats that seem to replicate one another. Baker's Pool of London is a jostling bustle in comparison: the proliferation

of unique vessels, with their rigging and sails, describes a crowded, cacophonous milieu negotiable only to the initiated.

The river provides an important thoroughfare through the city, a role that is demonstrated by the diffuse light falling on the water, creating a shining path leading into the picture. This promise is diluted though, by the two coal barges, each towing further vessels, which both try to proceed along the river, making the way ahead seem narrow, almost inadequate. The river's edges are undefined and overburdened with information: manned craft, their active participation signified by figures on deck or funnels pumping out exhaust, emit signals liable to travel in all directions at once, across the river as well as down it. The layers of rigging resemble clogged telegraph wires, in which messages sometimes seemed to get lost or garbled. The boatmen hard at work, arms raised, outstretched or akimbo, perform a kind of unconscious semaphore, their roles, actions and intentions apparently legible to one another but opaque to the uninitiated.

The painting offers a somewhat ambivalent portrayal of industry, commerce, and imperial power, all of which depended both upon the Thames as a shipping route and on efficient distribution – and sometimes containment – of information. Although this busy working stretch of river is illustrated with confidence and energy, the composition lacks order. The river is open in the foreground, but a bridge with the city gathered behind it obstructs the distance, and plumes of exhaust veil the way ahead. The combination of areas that have been effaced by clouds of smoke or sails and the intricacy of detail produce an impression of clutter, confusion and uncertainty. Baker's Thames appears to be a metaphor for a system running at maximal capacity after years of unchecked growth and development.

NH

CATALOGUE ENTRY D13 | DISTANCE

CLARKSON STANFIELD (1793–1867)

# MEN-OF-WAR OFF PORTSMOUTH, HAMPSHIRE, 1855

47 X 77 cm

GUILDHALL ART GALLERY, CITY OF LONDON CORPORATION



This painting depicts a fleet of warships in the English Channel on a choppy sea, under a large cloudy sky. A dinghy full of sailors is travelling either towards the central ship or away from it. Although there is a buoy in the foreground and some distant vessels are shown far away on the horizon, most of the subject matter appears in the middle distance, and around the line of the horizon. This gives a sense of shallowness to the picture, but this is undermined by the cloud formation, which produces a telescopic effect, as though the clouds form a tunnel leading into an endless void. John Ruskin, who admired Stanfield and called him ‘the leader of the English Realists’, complained about his treatment of ‘the sky, which is apt to be cold and uninventive ... with a kind of hesitation in the clouds whether it is to be fair or foul weather’.<sup>1</sup>

The double impression of shallow flatness and illusory depth is probably a result of Stanfield’s early training as a scene decorator in the theatre. He later progressed to easel painting, specialising in marine subjects; having spent a short time in the Navy, he had a sophisticated understanding of rigging and other naval technology. Ruskin had another complaint with regard to Stanfield’s boats, which he considered to be accurate but also idealised: they ‘always look newly painted and clean’.<sup>2</sup> In his 1836 book *Stanfield’s Coast Scenery: A Series of Views in the British Channel*, the artist notes the strategic importance of Portsmouth Harbour, which was both protected by the Isle of Wight and ‘unrivalled for capaciousness’. The Spit, a hidden sandbank ‘marked out by buoys at regular intervals’, was ‘often the spot for the assembling of the English fleet’.<sup>3</sup>



In this painting, the presence of the Spit can be inferred from the rough foamy waves in the foreground. Marked by a connected string of buoys, its submerged bulk can be seen as a referent for the Anglo-French cable that was laid under the Channel in 1850. The carefully rendered rigging on the line of vessels, meanwhile, holds pennants as well as sails, providing infrastructure for a primitive optical signalling; rigging is also reminiscent of aerial telegraphic cables.

The calm, deep waters where the ships are gathered seem to rise behind the foamy shallows, an odd optical effect that gives the painting a theatrical and slightly mysterious atmosphere. The choppy waves in the foreground, meanwhile, establish a rhythm that is picked up by the distribution of vessels and splashes of red across the canvas. The brightly coloured British flag, standing out against a muted palette, heralds an era of increasingly aggressive colonial expansion facilitated by the Navy. The telegraph was considered an important military tool, particularly early on, before its enormous commercial potential had emerged.

Stanfield became a full member of the Royal Academy in 1835, and although this painting was not shown there he did exhibit three other works at the Summer Exhibition in 1855, including *Ilfracombe, North Devon* (no. 87) and *Dutch boats entering harbour* (no. 142). His European travels provided rich subject matter in addition to his British coastal scenes; he produced two series of Venetian views and a collection of European river lithographs. He also illustrated editions of works by Lord Byron and Samuel Johnson.

NH

1. John Ruskin, *Modern Painters*, vol. 1 (1843), in E. T. Cook and Alexander Wedderburn, *The Complete Works of John Ruskin*, vol. 3 (London: George Allen, 1903-1912), p. 226, 227. Online at <http://www.lancaster.ac.uk/users/ruskinlib/Pages/Works.html> (consulted 2 September 2016).

2. *Ibid.*, p. 228.

3. C. Stanfield, *Stanfield's Coast Scenery: A Series of Views in the British Channel* (London: Smith, Elder and Co., 1836), p. 30.

CATALOGUE ENTRY D14 | DISTANCE

GUSTAVE DE BREANSKI (1859 – 1899)

# HASTINGS, EAST SUSSEX, 1884

76 X 127 cm

GUILDHALL ART GALLERY, CITY OF LONDON CORPORATION



Ferocious winds batter the south-east coastal town of Hastings, huddled beneath a dark and stormy sky. The foreground shows waves crashing onto the beach at low tide; further along men struggle to pull a large object from the surf. The idea that they are recovering a wrecked boat, partially obscured by rushing water, is further evoked by a pile of dark seaweed tendrils resembling shattered timber, which lies prominently in the foreground. A smack, with distinctive reddish sails, lies out at sea beyond the breakers, while above the seawall a crowd gathers beneath a tall, skeletal structure, which could be a flagstaff, crane or possibly an electric ‘moonlight tower’, a high lamp for illuminating large areas (here serving traffic on the water as well as onshore, and presumably offering valuable signalling opportunities).<sup>1</sup>

Hastings had traditionally relied on its fishing industry, but after becoming connected by rail in 1851 the town became a popular tourist destination, leading to rapid westward growth and the opening of a pier in 1872. Despite the town’s dependence on fishing, historical attempts to build an artificial harbour had failed; even today boats still have to be launched from the beach, making them vulnerable to bad weather. One commentator complained that ‘[s]ome of the most picturesque boat-houses were literally carried into the sea during one of the recent gales off this coast’;<sup>2</sup> while a letter published in the *Morning Post* suggests that town’s development was a direct threat to the safety of the fishermen and the survival of the fishing community.<sup>3</sup>

De Breanski makes a strong visual distinction between the modern pier far in the distance, crouching grey and reptilian grey in the stormy sea, and the earthy palette of the Old Town with its residential buildings and ant-like population. This was the domain of the fishermen and their families; its colours harmonise with the vibrant, reddish sand and forest of timber masts on the beach. The low viewpoint further suggests an earthbound perspective, but also enhances the enormity of the steely sea and sky that occupy most of the canvas; the figures and town are crowded into one corner, threatened by the advance of the sea. The smack stands out against the grey waters, picking up the warm palette of the shore as though drawn inland, although the prospect of landing is fraught with danger.

The open stretches of sea and sky with their grey, abstract patterns of cloud and wave suggest spaces that are still unmapped and unknowable, in juxtaposition with the more legible recession of the land. On shore, familiar representational forms give shape and metre to the pictorial space, from the nearby stones and seaweed to the groups of men scattered along the beach and the boats stored above the tide line. In the distance the land rises above the Old Town, offering a vertical mapping of space, with the castle on the hill as a landmark. This depiction of hubris portrays humanity as locked in a struggle with the elements, with modern advances and ingenious technology destined to be dwarfed by Nature's power: erosion and violent weather had damaged the castle over centuries, while the closely packed boats on the shore have a temporary air that infects the town above them.

Gustave de Breanski's sister Julie and brother Alfred, who was the most famous of the three, were also painters. Gustave specialised in coastal and marine subjects and was drawn to the depiction of weather. In 1885 he exhibited two paintings at the Royal Academy exhibition: *Seaton Bay and Peel Harbour*. He also showed work extensively at less established London venues, including the Dudley Gallery Art Society where he received favourable attention for another 1884 marine painting, *Return of the Brixham Fleet*, in the *Illustrated London News*.<sup>4</sup>

NH

1. The red sails of the smack were the result of tanning. Moonlight towers were very tall arc lamps, for locations where street lighting would have been impractical or expensive: here such lighting would have illuminated the beach and water as well as the old town.

2. 'The Hastings Fisheries', *Graphic* (6 December 1884), p. 603.

3. 'The town authorities have for years been squeezing the fishing craft from their ancient quarters nearer and nearer to a point bearing the appropriate name of "Foul ness," and the danger to the fishing craft has been increased. ... The old town is very dependent upon the fishery ... but the west end of the town has grown too strong for the old part ... and these poor fellows' lives are endangered more than formerly.' 'The Wreck of the Fishing Lugger at Hastings', *Morning Post* (16 December 1884), p. 6.

4. 'M. Gustave De Breanski's "Return of the Brixham Fleet" (206), a group of fishing boats beating round the point into harbour, is full of life, and well renders the cold grey sky and water which even the Devonshire coast can at times show'. 'The Dudley Gallery Art Society', *Illustrated London News* (1 November 1884), p. 419.

CATALOGUE ENTRY D15 | DISTANCE

ALBERT GOODWIN (1845–1932)

## THE TOILER'S RETURN, 1877

97 X 142 cm

GUILDHALL ART GALLERY, CITY OF LONDON CORPORATION



This painting shows a village on the north Devon coast, from a high inland viewpoint. A mother in simple working clothes and apron rushes with her children to the edge of the cliff to gaze at a fleet of approaching boats, still only specks in the distant water. Beneath them lies a bright, busy village, smoke pluming from a chimney and laundry hanging on a line; at the water's edge tiny foreshortened figures are dispersed along the beach. Several devices, including the curve of the shoreline, the jetty and the upright posts holding nets and laundry, all draw the eye to a distant point of deep blue in the sky, just above the horizon, where the clouds have parted.

The work was exhibited at the Royal Academy summer exhibition of 1877 (no. 1329 as *The Returning of the Toilers*), along with *A Baptism of Flowers* (no. 509), which elicited more critical attention. Of that painting, Tom Taylor commented that its effect depends 'on the combination of figures and landscape, the former telling the story to which the latter is attuned. This is always likely to be the form in which landscape will be most impressive to a mixed public such as that which fills the rooms of Burlington House'.<sup>1</sup>

Taylor's comment is equally applicable to *The Toiler's Return*, which has a strong narrative component. The bright colours of the diminutive village, arrayed below like children's toys, emphasise the built human environment, as distinct from the vast scale of the sky, open sea and wild, far-away cliffs across the water. The poses of the figures are emotive and

characterful, with each responding in a distinct way to the impending arrival: the mother twists her body to gaze wistfully out; the little boy grips the fence and peers through it; another boy leans over the fence close to his mother; the girl runs with arms outstretched, a pose echoed by the baby raised aloft. Their averted faces make them universal, while their vulnerability, conveyed by their simple clothes and the children's bare feet, further arouses empathy.

The painting is suffused with a golden light that evokes the nostalgia of childhood memories and enhances the emotional quality of the landscape. The laundry catches the breeze like the sails on the distant boats, the snowy whiteness standing out, along with the waving baby, as a form of semaphore signalling to the returning fishermen. The baby holds up its arms in excitement, as though embodying this message. The dark, perforated nets also resemble sails, a shadowy counterpoint to the hopeful whiteness and a reminder of the dangers facing the fishermen, the insecurity of their livelihood and the uncertainty that this particular husband and father is among those returning. This threat is underscored by the broken fencing barely protecting the family from a precipitous drop down to the shore.

Such details contrast with the wide, flat, indifferent blue of the sea and the pale sky, exhilarating and vast. The immensity is driven home by the great shadow visible in the bay, a reflection of the sky or of the seabed. These effects were noticed by a critic who described the painting as a 'fine, expansive, and noble view in cloudy light, and almost stereoscopic in treatment'.<sup>2</sup> This three-dimensional effect derives partly from the high viewpoint and the treatment of colour, but the comparison with a stereoscopic view is appropriate given that the painting is as much about travel as it is about distance, comparing the relative stability of village life with life at sea.

Goodwin travelled extensively during his lifetime, in Britain, Europe and beyond, to India, America, the West Indies and Antipodes. John Ruskin had been impressed by Goodwin's precocious talent (he made his first successful Royal Academy submission at fifteen) and sponsored some of the early European travel. Goodwin was best known for his watercolour landscapes and was widely considered 'the legitimate successor of Turner', an artist whose work he admired enormously.<sup>3</sup> An 1876 review of two landscapes describes Goodwin as 'a true artist, who is looking at nature for himself, free from recipes and conventions... Like some of the French impressionists, he prefers to deal with exceptional effects and aspects'.<sup>4</sup>

NH

1. 'Royal Academy Exhibition: IV', *Graphic* (9 June 1877), p. 543.
2. 'The Royal Academy', *Athenaeum* (26 May 1877), pp. 675–678.
3. 'Mr. Albert Goodwin's Drawings at the Fine Art Society's', *Standard* (30 October 1893), p. 2.
4. 'Fine Arts. Exhibition of the Society of British Artists', *Illustrated London News* (8 April 1876), p. 354.

CATALOGUE ENTRY D16 | DISTANCE

# NICKEL SILVER MICROMETER, ELLIOTT BROTHERS, LONDON

KING'S COLLEGE LONDON ARCHIVES K/PP107/11/2/4

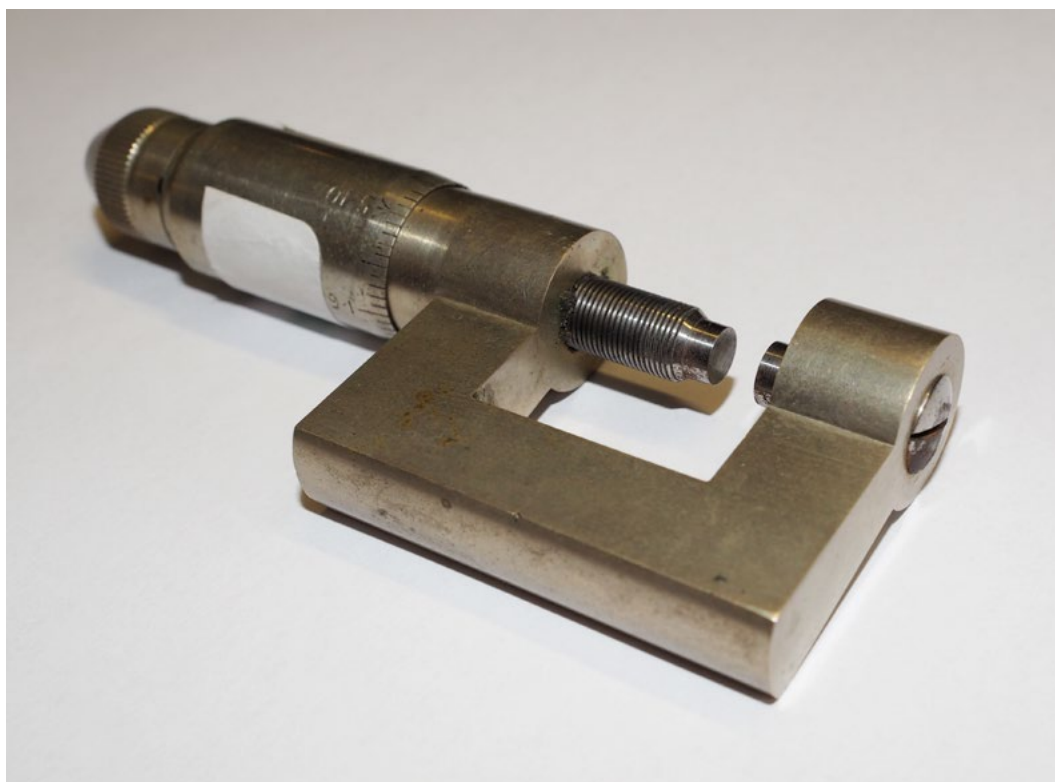

What separates Victorian engineering from that which had gone before is scale. Big projects, such as the Atlantic Telegraph, needed not just big ideas but new kinds of engineering. The micrometer brought the precision and attention to detail which made large, ambitious projects possible.

The micrometer began its life as a seventeenth-century tool for astronomers to measure the distance between stars. Its popularity increased through the eighteenth century in other precision industries such as machine tool making, screw-thread cutting and die making. Up until the mid-nineteenth century micrometers were large bespoke specimens only to be found mounted on the chief engineer's bench in specialist workshops. The best of these bench-mounted units, such as Henry Maudslay's 'Lord Chancellor' could measure accurately to one ten thousandth of an inch (0.00254mm).<sup>1</sup> The first hand-held micrometer was patented in 1848 by Jean Laurent Palmer of Paris and was capable of measuring to 0.05mm. The micrometer is still referred to as a 'Palmer' in France.

The micrometer in the exhibition is made by Elliott Brothers, a long-established London instrument makers.<sup>2</sup> Elliott Brothers offered a wide range of surveying, navigational, and philosophical instruments and produced a large proportion of the standard instruments



sold to both home and overseas customers. Elliott Brothers worked closely with academics and engineers to remain at the forefront of instrument making. Their customers included James Clerk Maxwell, Charles Wheatstone, Lord Rayleigh and other leading scientists. The micrometer from Wheatstone's collection is engraved Elliott Bros London, a mark used between 1873 and 1916. As Wheatstone died in October 1875 it serves to illustrate how Wheatstone remained research-active; purchasing cutting-edge engineering tools right up to his unexpected death on a work trip to Paris.

Perhaps more than any other instrument, the micrometer underpinned the nineteenth-century doctrine of Interchangeability; the idea that each component could be replaced by an exact copy without it having to be specially made. Previously, if a part broke or wore out, a new, bespoke part would be machined to replace it. A standard component, however, could be quickly swapped for a new one, 'out of the box'. Objects taken for granted today, such as the humble nut and bolt, became possible for the first time.

This trend was reflected across science and engineering and driven for a large part by the telegraphic industry. Landline engineers demanded - and received in 1883 - an agreed Wire Gauge as a measure of cable and wire diameter.<sup>3</sup> Atlantic cable engineer William Thomson lobbied parliaments for the standardisation of purity in metals, making telegraphic conductors reliable over long distances.<sup>4</sup> And, from 1862, telegraphic engineers and physicists strived to find ways to measure and define electrical engineering units; the volt, amp, ohm and farad. Interchangeability was not simply about standardisation, it was also about mass manufacture; bringing the costs of engineering down and allowing previously uneconomic projects – such as the Atlantic cable – to be undertaken.

The success of the telegraph rested upon the idea that every cable house, everywhere in the world had access to the same screws, the same clamps, and the same instruments, all manufactured to the same, micrometer-exact specifications. If any part failed a new one could be taken from the store or sent from any other nearby cable house. Interchangeability underlies all large, networked technologies, which rely on each individual node being able to operate independently and at arms' reach.

CN

1. R. H. Maudslay, 'Henry Maudslay, Engineer: Paper prepared from a lecture given to the Newcomen Society, Manchester Assoc. of Engineers and Museum of Science and Industry, 29 Jan, 2008', <http://www.mae.uk.com/Maudsley.PDF> (consulted 4 September 2016).

2. Grace's Guide, 'Elliott Brothers', *Grace's Guide to Industrial History*, (8 August 2016), [http://www.gracesguide.co.uk/Elliott\\_Brothers](http://www.gracesguide.co.uk/Elliott_Brothers) (consulted 4 September 2016).

3. Aashish Velkar, 'Accurate Measurements and Design Standards', *Working Papers on the Nature of Evidence: How Well do 'Facts' Travel?*, *London School of Economics*, Vol. 18, No. 07, (2007), <http://www.lse.ac.uk/economicHistory/pdf/FACTSPDF/FACTs18AV.pdf> (consulted 4 September 2016).

4. Bernard Crossland, 'Kelvin and Engineering', in Raymond Flood, Mark McCartney, Andrew Whitaker (eds.) *Kelvin: Life, Labours and Legacy* (Oxford and New York: Oxford University Press, 2008).

CATALOGUE ENTRY D17 | DISTANCE

# THREE SAMPLES OF SIEMENS' ATLANTIC TELEGRAPH CABLES

KING'S COLLEGE LONDON ARCHIVES. K/PP107/11/1/18



The completion of the 1866 and recovery of the 1865 cables was inspiring. It showed that the great spanning of the Atlantic was possible. It gave governments and engineers confidence. It also gave them a test-bed on which ideas could be worked out, proved and disproved. Bandwidth – initially restricted to 8 words per minute – was in high demand and the market was ripe for expansion.

Siemens brothers had begun experimenting with submarine cables back in the early days of telegraphy. Indeed, in 1846, Werner von Siemens was already experimenting with gutta-percha (a natural sap, a bit like latex) sent to him by his brother William. Impressed with its insulative properties, Werner sought the support of the Prussian Telegraph Commission and trials took place, which were a resounding success.<sup>1</sup> His design for gutta-percha insulated cables formed the basis for most subsequent submarine cables.<sup>2</sup>

The successful Atlantic cables of 1865 and 1866 featured several innovations which were rapidly adopted throughout the industry. These included a double layer of armouring on the 1865 shore-ends and the introduction of stranded wires to provide a more flexible armouring. The Siemens brothers improved upon this successful design for their Direct United States and Compagnie Française Paris-to-New-York Atlantic cables.

The 1874 Direct United States Cable was the first to feature a larger diameter central wire surrounded by a number of smaller wires. More copper could in this way be fitted into a smaller volume which made for lower resistance, lower capacitance and better signalling speeds.<sup>3</sup> More words per minute meant better profits and at 50 words per minute in both directions (known as duplex working) the first of the new Siemens cables brought about a sea-change in telegraphy speeds.

Also built for the 1874 Direct United States cable was the CS (Cable Ship) Faraday, the first purpose built cable ship. Her design was highly innovative featuring a sharp, bow-like stern giving her distinctive lines. She was fitted with twin-screw propulsion for manoeuvrability and swinging sheaves at both the bow and stern to reduce strain on the cable during laying. The Faraday would go on to complete 50 years of cable work.<sup>4</sup>

The 'Direct', as it became known, was sold to the Anglo-American cable company in 1877 and bought again by the General Post Office in 1920. In 1943 the cable failed and engineers were not able to repair it until 1952 when it was finally put back into working order.<sup>5</sup> The cable continued in use well into the 1950s and is the only cable known to have had the shore end landed through a petrified forest.

CN

1. W. Feldenkirchen, *Werner von Siemens: Erfinder und internationaler Unternehmer* (Berlin: Piper, 1996).

2. G. Preece, 'On Underground Telegraphs', *Journal of the Society of Telegraph Engineers*, vol. 2, no. 6 (1873).

3. B. Glover, *Direct United States Cable Company* (2015), <http://tinyurl.com/hb2pgu6> (consulted 4 September 2016).

4. W. Siemens, 'The Steamship 'Faraday' and her Appliances for Cable-laying', *Journal of the Royal Institution of Great Britain*, vol. 7 (1874).

5. Glover, *Direct* (2015).

## CATALOGUE ENTRY D18 | DISTANCE

CHART SHOWING THE INTENDED TELEGRAPHIC COMMUNICATION BETWEEN NEWFOUNDLAND AND IRELAND, TRACKS OF STEAMERS BETWEEN EUROPE AND AMERICA AND THE ICE FIELDS IN THE NORTH ATLANTIC OCEAN (WITH SECTION OF THE BOTTOM AND OF THE CABLE TO BE USED). SCALE: 1 INCH TO ABOUT 150 MILES. SURVEYED BY CYRUS W FIELD. ENGRAVED BY DAY AND SON, ENGRAVERS AND PUBLISHERS. MADE FOR THE NEW YORK, NEWFOUNDLAND AND LONDON TELEGRAPH COMPANY, 1856

THE NATIONAL ARCHIVES, UK, MPG 1/392.

Maps are not neutral devices. Maps have power. They shape our understanding of places and of the relationships between those places. They tell us what is important and what may be disregarded. They determine our world view. Harley speaks of maps as ‘a collection of codes’ and urges us to deconstruct the map in search of the social forces that have structured cartography;<sup>1</sup> to read between the lines of latitude and longitude for the implicit politics, economics and cosmologies there printed.<sup>2</sup>

The two charts juxtaposed in this exhibition (D18 and D19) were chosen because they capture beautifully how the Atlantic Ocean was envisioned by people in Britain and America both before and after the laying of the Atlantic cable. In this, the first chart, Atlantic cable power-house Cyrus Field shows the intended telegraphic communication between Newfoundland and Ireland. His map depicts an Atlantic full of ice-flows, shoals, currents and wrecks. It is scrawled over by the wavering trails of ships, whose wind-driven paths meander, overlap each other and diverge. Superimposed over these comings and goings (for the benefit of potential investors), is the hard line of the proposed telegraph. It curves smoothly between Newfoundland and Ireland, slicing through, under and over the petty and frantic travellings of ships, currents and people; cutting edge and unstoppable. On land the telegraphs snake across Europe and the Americas, temptingly projecting the onward journeys for trans-Atlantic messages. The chart tellingly dates from 1856, the beginning of the Atlantic cable project and before the three expensive and high profile failures. It naively imagines the Atlantic telegraph cable as a serene triumph of Victorian engineering rather than the pitched and improvised battle against the elements it became. The message Cyrus Field intended this chart to convey was ‘we understand this’, ‘we can do this’ and, importantly ‘give me all your money’.

CN

1. J. B. Harley, ‘Deconstructing the Map’, in T. J. Barnes and J. S. Duncan (eds.), *Writing Worlds: Discourse, Text and Metaphor* (London: Routledge, 1992), p. 238.

2. J. B. Harley, ‘Deconstructing the Map’, *Cartographica*, vol. 26, no. 2 (Spring 1989), p. 3.

## CATALOGUE ENTRY D19 | DISTANCE

COAL AND TELEGRAPH CHART': SHOWING TELEGRAPHS AND COALING STATIONS. ADMIRALTY CHART 1188: ENGRAVED BY EDWARD WELLER; PUBLISHED, 8 AUGUST 1889.

THE NATIONAL ARCHIVES, UK, MPH 1/454.

This chart, engraved for the Admiralty in 1889 shows overland telegraphs, submarine cables, steamer routes and coaling depots; an Atlantic criss-crossed by communications technologies. It was made twenty three years after the successful laying of the 1866 cable, which at this date figures as just one of several threads almost casually spanning the Atlantic Ocean. The world has been changed. Known infrastructure now takes the place of wild waves. Unpredictable ocean currents are replaced by calm electrical ones. Messages cast out into the sea are now tethered safely by the cable. The impossibly ambitious Atlantic cable project is now just one link in a near-global network; simultaneously indispensable and ubiquitous. In this chart, the novelty has worn off. The slim, pioneering thread now finds itself integrated into a wider-reaching network of landlines, direct steamship routes, forts, train-lines, ports and harbours. The telegraph has morphed from pioneer species to networked object; jig-sawed into an increasingly anthropocentric landscape. The chart speaks of the expansion of minds, the permeation of Admiralty views to land-lubbers; that oceans are traversable and vast distances communicable. These ideas now belong to everyone. We know that for the price of a telegram that infrastructure can be mobilised. For pounds, shillings and pence oceans can be shrunk and the least of our thoughts sent out to conquer icebergs, tides and storms.

CN

# TRANSMISSION



TRANSMISSION

# CLARE PETTITT

DISPERSED CONSCIOUSNESS: EVELYN DE MORGAN'S *MOONBEAMS  
DIPPING INTO THE SEA*



Fig. 1, Evelyn De Morgan, *Moonbeams Dipping into the Sea* (1900), Courtesy of the De Morgan Foundation.

Painted at the very end of the nineteenth century, Evelyn De Morgan's *Moonbeams Dipping into the Sea* shows three linked female nudes reaching down from one source of energy, the moon, to another, the sea. Like others of her paintings of linked bodies (*The Sea Maidens* [1885-1886] and *The Captives* [1900-1919]) all the women in *Moonbeams* look very similar to one another, their features barely differentiated, and their eyes downcast. The nude forms are gigantic but graceful, the series unspooling in a luminous, almost iridescent space. The flat surface of the sea into which the third maiden dips her legs and trails her fingertips is shimmering with accents of purple and green like spilt petroleum. The dominant blues and purples of the sky above are contrasted with the copper colour of the girls' flowing hair. Elise Lawton Smith has noticed the way that the 'diaphanous drapery...coils around the figure of the moon and flows along the bodies of the two other women who are also connected to her by the gentle linking touch of their hands'.<sup>1</sup> The painting asks us to think about transmission, about energy, about connectivity, and about the force created by the positionality of bodies.

Like her husband, the ceramic artist, William De Morgan, and her mother-in-law Sophia De Morgan, Evelyn De Morgan was a committed Spiritualist.<sup>2</sup> The London weekly spiritualist journal *Light* defined spiritualism at this time as, 'a belief in the existence and life of the spirit apart from and independent of the material organism, and in the reality and value of intelligent intercourse between spirits embodied and spirits discarnate'.<sup>3</sup> De Morgan's work is always intensely interested in the relationship between the 'embodied' and 'discarnate'. In her painting, her intense sculptural interest in the flesh and solidity of the human form is always in tension with movement, fluidity and connective forces that move through and beyond the limits of the body.

From their early married days Evelyn and William De Morgan always set aside a little time every evening to experiment with automatic spirit writing. One would hold a pen, the other would lay their hand gently over their partner's and they would await the messages from the spirits. The spirits were not always communicative, and the connection was fragile: '[there] followed long intervals of highly unsatisfactory writing; sometimes accounted for as "the wires having got wrong", or else by the physical condition of the "mediums" making it impossible'.<sup>4</sup> 'The wires having got wrong' is an important metaphor and one that reappears often in the writing about spiritualism in this period. The connections and transmissions between the spirit world and this 'embodied' world were often described with electrical and telegraphic imagery. The American medium, John Murray Spear, for example, described the 'spirit-telegraph' as 'a connection, a telegraphic communication, by means of what may be termed an Electric chain'.<sup>5</sup>

The linked figures in *Moonbeams* create a kind of 'electric chain' or telegraphic cable, their bodies forming the cable core: and the metallic gleam of the paint surface suggesting the



conductivity of metals – the copper of their hair, the silver of the sky and the salt water of the sea all replete with possibilities for electrical transmission. The components are in fact close to those of a Leyden Jar, or a battery, and the legs and arms of the figures create a circuit from sea to moon and back again. The greenish coppery coloured drapery is coiled around the bodily core but it seems to flow like a liquid or a gas rather than hang and fold like a fabric. It answers to the description of ectoplasm, the ‘semi-luminous thick vapour’ which sometimes appeared from the orifices (often the mouths) of mediums at spiritualist séances, and which was also known as ideoplasm or teleplasm.<sup>6</sup> Indeed, if we read this substance as ectoplasmic in De Morgan’s painting it seems less a conventionally Victorian veil of modesty covering the genital areas of the women and appears instead as a substance which flows through and out of their bodies and threads them together through their bodily openings. Marina Warner has written that ‘[a] medium’s body became a porous vehicle as the phenomena exuded from mouth, nose, breast and even vagina: she acted as a transmitter, in an analogous fashion to the wireless receiver, catching cosmic rays whose vibrations produced phantoms and presences’.<sup>7</sup> In William De Morgan’s first novel, *Joseph Vance* (1906), the Swedenborgian character, Dr. Thorpe, realizes that, ‘there are two distinct classes of people in the world; those that feel that they themselves are in a body; and those that feel that they themselves are a body, with something working in it. I feel like the contents of a bottle, and am very curious to know what will happen when the bottle is uncorked’.<sup>8</sup> Evelyn De Morgan seems to have shared this curiosity and her late work uncorks and opens up the body in order to plug it into the larger energy flows around it. Much later, in the twentieth century, the media theorist, Marshall McLuhan would describe a ‘media sensorium’, where the ‘central nervous system’ is ‘outered’ to become a technological field.<sup>9</sup> De Morgan seems to be visualising such a possibility in paintings in which the ‘inside’ of the body becomes outered and forms a sensory circuit with its environment.

Physicists, chemists and biologists in search of ‘protoplasm’ or the ‘strange, elusive, protean, all-pervading substance’ which would unlock the composition of the material world took the idea of ectoplasm seriously.<sup>10</sup> Warner notes that it was thought that, ‘[d]arkness was essential for the phenomena to appear...William Crookes, the great Victorian experimental chemist, preferred moonlight, and reported excellent results by this pale illumination’.<sup>11</sup> While De Morgan was creating the impression of ‘pale illumination’ in paint in *Moonbeams*, physicists were beginning to shift towards a new quantum view of the universe. In the 1890s, scientist Oliver Lodge had moved towards radiotelegraphy with his experiments in wavelengths, while remaining a wholly committed member of the Society for Psychical Research.<sup>12</sup> His theory was that ectoplasm was identical to the substance he called ‘Ether’ which he defined as ‘the *tertium* quid, the essential intermediary’ and ‘the vehicle of both matter and spirit’. The Ether was ‘the seat of all electric forces, and indeed the sole transmitter of force’, and it could ‘transmit vibrations from one piece

of matter to another'.<sup>13</sup> Lodge was not alone. Many scientists maintained an idea of the ether as 'a transparent universal medium that permeated the spaces between particles, thus acting as a transmitting device (for electromagnetic waves, as one nineteenth-century theory proposed, or, on another level, for messages from the spirit world)'.<sup>14</sup> And at the turn of the century Guglielmo Marconi's breakthrough work on wireless technology showed that the air itself could carry signals, without the need of cabling or wiring. Wireless was hailed as 'a new sense' which could provide 'not the ghostland of the heated imagination cultivated by the Psychical Society, but a real communication from distance based on true physical laws'.<sup>15</sup> Jeffrey Sconce claims that wireless 'heralded a radically different vision of electronic presence, one that presented an entirely new metaphor of liquidity in telecommunications by replacing the concept of the individuated "stream" with that of the vast etheric "ocean"'.<sup>16</sup>

Evelyn De Morgan's later work offers a visualisation of dispersed media, or what Joe Milutis calls the 'electric sensorium' of the ether in an attempt to define 'a space of collective sensation'.<sup>17</sup> In the De Morgans' automatic writing, the ideal of a collective dispersed consciousness returns again and again: '[s]tretch out a hand and grasp the wealth that is lavished on all who will have it, and listen to the music that sounds through creation, till personal aches and miseries are drowned in the great chorus of rejoicing'.<sup>18</sup> In her painting De Morgan dissolves the individual into a series and, by this replication of the body, she fantasises the perfect telepathic transmission. Michel Serres points out that '[e]very system is a set of messages; in order to hear the message alone, one would have to be identical to the sender...As soon as we are two, there is a medium between us, the light ray is lost in the air, the message is lost in the interceptions, there is only a space of transformation'.<sup>19</sup> But the beams of moonlight are not lost in the air in De Morgan's image. Because the figures are perfect copies of one another, the message is reproduced without distortion. Her late work tries to eliminate the noise and interference of the media in order to restore transparent transmission. There is a gendered purpose here too, as the ethereal environment she creates for the naked female bodies in her paintings removes them from the social and political force-fields that constrained women in late nineteenth-century society. The disjunction from the social which is common to all of her late work perhaps also explains the much-noticed lack of erotic charge to her nude female figures. Without the mediation of an eroticised context these women's bodies become affectless solid matter.<sup>20</sup> The affect in De Morgan's work is transmitted elsewhere, into the atmosphere, into the ether.

As the full electromagnetic spectrum was slowly being discovered and described in the late nineteenth century, it was already becoming clear that we might be able to locate ourselves electromagnetically: 'a time would come when if a person wanted to call to a friend he knew not where, he would call in a small electro-magnetic voice ... "Where are you?" ...

A small reply would come, “I am at the bottom of a coal mine, or crossing the Andes, or in the middle of the Pacific”.<sup>21</sup> This new-wave ‘ether’ was understood as both a medium and an environment, so that we could locate ourselves in it and use it to communicate. As Marshall McLuhan pointed out, electricity is, importantly, not about containment, but rather about relation and positionality between bodies: ‘[a]gain, as more is known about electrical “discharges” and energy, there is less and less tendency to think of electricity as a thing that “flows” like water through a wire, or is “contained” in a battery. Rather, the tendency is to speak of electricity as painters speak of space; namely, that it is a variable condition that involves the special positions of two or more bodies’.<sup>22</sup> Evelyn De Morgan expresses space in her painting by the positioning of bodies to create atmospheric energy. Her aesthetics are the aesthetics of an emerging teleworld in which human subjects become networked objects in a complex field of energies.

1. Elise Lawton Smith, *Evelyn Pickering De Morgan and the Allegorical Body* (London: Fairleigh Dickinson University Press, 2002), p.132.
2. Sophia De Morgan, Evelyn De Morgan's mother-in-law, was enthusiastic about the beliefs of Emanuel Swedenborg (1688-1772) and she wrote and published Swedenborgian treatise: Sophia De Morgan, *From Matter to Spirit: The Result of Ten Years' Experience in Spirit Manifestations* (London: Longmans and Green, 1867).
3. Arthur Conan Doyle, *The History of Spiritualism*, vol. 2, ch.10. Quoted Lawton Smith, Evelyn Pickering De Morgan (2002), p.41.
4. Evelyn De Morgan and William De Morgan, *The Result of an Experiment* (London: Simpkin, Marshall, Hamilton, Kent, 1909), 'Preface' by the editor, pp. xii-xiii.
5. Alonzo E. Newton, ed., *The Educator, Being Suggestions Theoretical and Practical, designed to Promote Man-Culture and Integral Reform, with a View to the Ultimate Establishment of a Divine Social State on Earth, Comprised in a Series of Revelments from Organized Associations in the Spirit-Life, Through John Murray Spear* (Boston, MA: Office of Practical Spiritualists, Fountain House, 1857). Quoted in Bret E. Carroll, *Spiritualism in Antebellum America* (Bloomington and Indianapolis: Indiana University Press, 1997), p.69.
6. Arthur Conan Doyle, *History of Spiritualism*, Volume Two (1926) (Great Britain: Psychic Press Ltd., 1989), p. 89. Conan Doyle describes ectoplasm as 'ooz[ing] from the side or the mouth of a medium', p. 89.
7. Marina Warner, 'Ethereal Body: The Quest for Ectoplasm', *Cabinet Magazine*, Issue 12 (Fall/Winter 2003), <http://tinyurl.com/3ygc09l> (consulted 27 August 2016).
8. William De Morgan, *Joseph Vance: An Ill-Written Autobiography* (London: William Heinemann, 1908), p.372. Quoted in Elise Lawson Smith, Evelyn De Morgan (2002), p.45. Emphasis original.
9. Marshall McLuhan, 'Automation: Learning a living', in *Understanding Media: The extensions of man* (Cambridge: MIT Press, 1994), p.347.
10. Arthur Conan Doyle, *History of Spiritualism* (1989), p. 121.
11. Marina Warner, 'Ethereal Body', (2003).
12. The Society for Psychical Research (SPR), founded in 1882 by a group of prominent intellectuals, was the first learned society with the purpose of scientifically investigating psychic phenomena. For a recent collaborative research project on Oliver Lodge based at Birmingham University, see <http://www.oliverlodge.org/> (consulted 27 August 2016).
13. Oliver Lodge, *Ether and Reality: A Series of Discourses on the Many Functions of the Ether of Space* (1925) (Cambridge: Cambridge University Press, 2012), p.20, p.174, p.154.
14. Lawson Smith, *Evelyn Pickering De Morgan* (2002), p.164.
15. Professor William R. Ayrton, quoted during a discussion after a paper given by Marconi at the Royal Society, in Guglielmo Marconi, 'Syntonic Wireless Telegraphy', *Journal of the Society of Arts*, vol. 49 (17 May 1901), p.516 and pp. 516-517.
16. Jeffrey Sconce, *Haunted Media: Electronic Presence from Telegraphy to Television* (Durham and London: Duke University Press, 2000), p.14.
17. Joe Milutis, *Ether: The Nothing that Connects Everything* (Minneapolis: University of Minnesota Press, 2006), p.78 and Jennifer Gabrys, 'Atmospheres of Communication' in *The Wireless Spectrum: The Politics, Practices, and Poetics of Mobile Media*, ed. by Barbara Crow, Michael Longford, Kim Sawchuk (Toronto: University of Toronto Press, 2010), p. 57.
18. Evelyn and William De Morgan, *The Result of an Experiment* (1909), p.19.
19. Michel Serres, *The Parasite* (1980) (Minneapolis: University of Minnesota Press, 2007), pp. 69-70.
20. Jeffrey Sconce makes this point: '[f]or many women of the period, telegraphic presence was an important electrical space that dissociated the gendered body from the patriarchal realm of thoughts and ideas, thereby making possible new forms of political expression'. Jeffrey Sconce, *Haunted Media* (2000), p.14.
21. Professor William R. Ayrton, in Guglielmo Marconi, 'Syntonic Wireless Telegraphy' (1901), p.516.
22. Marshall McLuhan *Understanding Media: The Extensions of Man* (1994), p.347.

TRANSMISSION

# CAROLINE ARSCOTT

ELECTRIFYING THE LITERAL: TOPHAM'S *RESCUED FROM THE PLAGUE*

Fig. 1, Frank William Warwick Topham, *Rescued from the Plague, London, 1665*, 1898, Guildhall Art Gallery, City of London Corporation.

Frank William Warwick Topham's *Rescued from the Plague*, shows an incident described in the seventeenth-century text, Pepys *Diary*, in which a couple have lost all their children but one to the plague. They are confined to the house and their door is barred in accordance with the regulations in place to control the disease. In order to save their last child they arrange for a friend to come and take the little girl, stripped naked so that there is no chance of disease being passed on by contaminated clothing. The little girl is handed down from an upstairs window into the receiving arms of the friend; his little companion stands by with fresh clothes. The painting was described in the *Art Journal* as 'a picture with a strong human motive animating its inception'.<sup>1</sup> A motive force (human interest) is indicated as being there at the inception; this leaves it moot as to whether the animation follows through into execution of the work and its reception. Did the viewer feel the urgent emotional charge?<sup>2</sup> Could Topham's picture effectively transmit that human motive force? The reviewer has selected his or her terms with care because expectations were low where Topham was concerned.

The parallel indicated above between the delivery of the picture to the art world and the transfer of the child within the picture is carefully worked through. The story sees the force of parental love impelling the child outwards, to be received by the friend, but whether for future life or for death is not known. The strange, near-horizontal position of the child aligns her with recumbent nudes from the academic tradition of western art from Titian's *Venus of Urbino* to Cabanel's *The Birth of Venus*.<sup>2</sup> There are also echoes of renaissance scriptural subjects prompting meditations on life, death and immortality: the vertical format recalls Rubens's *Descent from the Cross*, the cradled figure Raphael's figure of Christ in *The Deposition*.<sup>3</sup> All this is at the core of a scene that is strongly reminiscent of seventeenth-century Dutch genre painting both in the spatial arrangement and the details of dress and buildings.<sup>4</sup> The most revered and elevated elements of high art are wrapped around by the neutral, truth-telling capabilities of the Dutch genre tradition.

The child is attached to the mother by their shared fond gaze, by the mother's cradling hands that have not yet released her, and also by the grasp of this child on the neck-ribbon of the mother. The friend on the street reaches up to cradle her in turn; his hand overlapping that of the mother. The burden (the message) passes between the mother and the friend. The precious child, scion of an apparently doomed family is the sole chance for the transmission of the family name and family line. Her curved body hanging on to the vertical neck tie exactly echoes the shape of the carved anchor set over the doorway of the house. This makes her an emblem of hope like the anchor. The slumped female figure in the doorway to the right shows that the outcome is not certain. In place of the pearly nakedness of the child we see a rusty-red shawl and bodice, red flowers appear in her headdress like wounds. The pale stone of the anchor has its sinister echo in the smeared, downwards-drifting cross daubed in red paint on the door. It has been put

there to indicate the presence of the plague. It hangs over the seated female figure who is an image of despair and perhaps of vice. The element transmitted in this case is disease rather than life and lineage.

Topham worked in both oil painting and watercolour. He exhibited regularly at the Royal Academy from 1876 and at the New Water Colour Society (NWS) from 1879.<sup>5</sup> He was elected as a member of the successor to the NWS, the Royal Institute in Water Colours, in November 1896. W. W. Topham's work was generally discussed in fairly scathing terms in art criticism of the 1890s. His emulation of 'a sumptuous Venetian manner' in 1891 was botched, it was thought.<sup>6</sup> His *Jack Ashore*, RA 1896 (no. 638) was summed up in the *Athenaeum* as lacking 'freshness or strength ... eminently respectable without being sincere or solid'.<sup>7</sup> In 1895 the same publication had half-heartedly praised work that was 'neat, pretty as a whole, and more deftly as well as correctly drawn, and more crisply touched than most of the artist's rather amateurish works'.<sup>8</sup> An article on modern religious art in 1898 emphasised the strong religious feeling and emotional strength of a number of artists including William Holman Hunt and Ford Madox Brown. When it came to Topham however the religious subjects were said to be illustrative rather than imbued with devotion and religious feeling; 'they contain no lessons in themselves: they fulfil their intention in turning our minds to the original stories'. Topham was said to paint 'illustrations of facts and incidents recorded in Scripture, and only intended as such. In saying this there is no detraction of their merits suggested'.<sup>9</sup> The example given is his *Naaman's Wife* (RA 1888): 'it is an illustration of an incident made as true to facts as the artist could arrive at them'.<sup>10</sup> Baldly literal, at best carefully composed and crisply executed, the anecdotal paintings were liable to deaden rather than to intensify emotion.

In the case of *Rescued From the Plague* Topham's anecdotal or illustrative method is recognised. The *Art Journal* critic who had commented on the powerful initiating human motive also commented on the rather out-of-date mode 'it is interesting to reflect on the change of fashion in art, and to recall how prolific was the output in historical and anecdotal genre twenty years ago'.<sup>11</sup> However Topham has selected a new source for his anecdote here. He is venturing, in this picture on tapping in to the power that came from the unique document that is Pepys's *Diary*. Pepys's *Diary* was well-known, but until the 1890s it had not been fully translated from shorthand and published. Until the appearance of the 1890s edition readers had 'been defrauded of nearly one-fifth of his delightful prattle' said *The Bookman*.<sup>12</sup> Once published in its entirety (barring some passages omitted for the sake of decency) commentators were astounded afresh by its directness and human qualities.<sup>13</sup> No rhetoric was apparent because it was evidently written for himself. The record was unique, it was said, because it contained no generalisations or reflections on destiny or the implications of deeds. In this respect he was considered as an opposite to Shakespeare

To Shakespeare the world was “full of strange noises; “ men and women were on a journey from eternity to eternity, and their loves and hates, ambitions and failures were imbued with the enchantment of destiny, so that, while all they do or say seems proper to them as individuals, it is but the manifestation of a power or process of which they are the unwitting mediums. To Pepys they are comprehensible men and women, with no other matter of destiny about them than birth and death. These mysteries he makes no pretence to solve, or dilate upon; they are mere memoranda for him, like the pickled herrings he dines off at Greenwich. The world for Pepys is most effectually real.

Topham attempts to refresh his art by selecting a source that transmits humanity and the real in the purest possible way. Encrypted in the Pepys manuscript diary (in shorthand and in Pepys’s own private code), or fully deciphered in the 1890s edition, was to be found, it seemed, the real. Topham believed the motive source of human experience was intact and available. In *Rescued From the Plague* he attempts to use Pepys like a battery or power source to electrify the literal and deliver his art to the public.

In the context of this exhibition the gambit is akin to the technique of increasing the voltage when sending a message down a long cable. The telegraph message was animated at its inception by an electrical charge. If transmission was successful the charge passed down the cable and was discernible at the far end as a distinct element of a message. Some telegraph engineers believed that the best way to ensure a clear signal was to maximise the voltage. Eventually this method was discredited on the basis that it damaged the line and reliance was placed instead on instruments that were responsive to faint signals.<sup>14</sup> Topham’s selection of Pepys’s Diary for his anecdotal painting was not necessarily going to ensure the favourable reception of his work by the critics and public of the 1890s.



1. *Art Journal* (June 1898), p. 174.
2. Titian, *Venus of Urbino*, Florence, Uffizi, 1538; Cabanel, *The Birth of Venus*, 1863, Paris, Musée d'Orsay.
3. Peter Paul Rubens, *The Descent from the Cross*, 1612-14, Antwerp, Cathedral of Our Lady; Raphael, *The Deposition*, also known as *The Entombment*, 1507, Rome, Galleria Borghese.
4. For instance Johannes Vermeer, *The Little Street*, c. 1657-58, Amsterdam, Rijksmuseum.
5. He was the son of genre painter and illustrator Francis William Topham (1808-1877).
6. *Saturday Review* (9 May 1891), p. 559.
7. *Athenaeum* (6 June 1896), p. 753.
8. *Athenaeum* (2 Nov 1895), p. 612.
9. The Author of "A Pictorial Life of Christ", 'Religion In Modern Art', *The Quiver* (Jan 1898), p. 394.
10. F. W. W. Topham's work was sometimes engraved for the religious press; engravings of his RA pictures appeared in 1888 and 1889 in *Sunday at Home*. For this purpose his illustrative approach prompting recall of the original story may have been advantageous. *Sunday At Home* (Nov 1888), p. 697; *Sunday At Home* (Nov 1889), p.15.
11. *Art Journal* (June 1898), p. 174.
12. *The Bookman*, vol. 5, no. 25 (October 1893), p. 24.
13. The Henry B. Wheatley edition appeared in 8 volumes plus 9<sup>th</sup> and 10<sup>th</sup> volumes containing index and addenda. The final portion of the diary was in vol. 8 published in 1896. Henry B. Wheatley, *The diary of Samuel Pepys, transcribed from the shorthand manuscript in the Pepysian library Magdalene college, Cambridge, by The Rev. Mynors Bright, with Lord Braybrooke's notes; edited with additions by Henry B. Wheatley*, 10 vols. (London: G. Bell & sons; Cambridge: Deighton Bell & co., 1893-1899).
14. For a critical assessment of the role of elevated voltage in the damage to the 1858 transatlantic cable see D. de Cogan, 'Dr E. O. W. Whitehouse and the 1858 trans-Atlantic Cable', *History of Technology*, Vol. 10 (1985), pp. 1-15.

TRANSMISSION

# CAROLINE ARSCOTT

GRIM SPECTRES: LOGSDAIL'S *THE NINTH OF NOVEMBER*, 1888

Fig. 1, William Logsdail, *The Ninth of November*, 1888, 1890, Guildhall Art Gallery, City of London Corporation.

The Lord Mayor's Show passes in front of the Royal Exchange. Puny footmen in elaborate livery are striding forward on the damp roadway, ahead of the Lord Mayor's coach. This was the shortest Lord Mayor's procession of the century; as an economy measure it had been scaled down. The show of traditional pomp in modern times is shown as awkward. The picture's theme is on one hand the effort to maintain transmission and on the other the forces that thwart transmission.

William Logsdail's *The Ninth of November*, 1888 was exhibited at the RA in 1890 (no. 1028) and was the only picture Logsdail showed in that exhibition.

This painting of the annual Lord Mayor's Parade gave Logsdail the opportunity to depict a central London location in a topographically accurate way, to indicate a representative crowd of modern city types, gathered as onlookers, and to elaborate a series of figures and vehicles representing the make-up of the parade. It sets up a striking contrast between the brilliant colours and shiny gold trimmings of the parade and the dull, largely monochrome appearance of crowd and street. The architecture is somewhat misted over in the cloudy atmosphere of a raw November day but the eight Corinthian capitals and the portico sculpture of the Royal Exchange are carefully depicted as the main backdrop for the procession.<sup>1</sup> The picture shows the view from the junction of Threadneedle Street

and Cornhill. Looking past the Royal Exchange to the left, along Threadneedle Street, Logsdail shows the buildings of the Bank of England. One roofline is punctuated by a regular row of ornamental urns, but the roof nearest to the picture's foreground is topped by figures of ladies and gentlemen, silhouetted against the sky, human equivalents to the stone vases.



Fig. 2, Portico sculpture (detail) The Royal Exchange, <http://tinyurl.com/gur5rq8> photograph by Robert Freidus.

The allegorical figure of commerce is shown in its position at the centre of the Royal Exchange portico. The portico sculpture was made by Richard Westmacott the younger; the group to the left of Commerce shows city officials including a Lord Mayor in his robes. By centring the picture on this building Logsdail is invoking the city as a nexus of regulated trading: prosperity and authority may be expected to support each other in the rational spaces of modernity. The building, designed by architect William Tite, was opened with great ceremony on 28th October 1844.

It is interesting to compare the format of a lithograph made of that ceremony with the composition of Logsdail's painting. The equestrian sculpture of the politician and military hero Wellington can be made out in Logsdail's picture as a shadowy horseman behind the horses drawing the Lord Mayor's coach. By contrast, in 1844, it was shown as a towering presence in amongst an ornamental display of parading horses and marching troops and lines of ceremonial carriages. In that image shadows are crisp and the ground is clear and bright between the lines of participants. The onlookers in 1844 are shown as minute,



Fig. 3, Newcombe after G. R. Smith, *The Opening of the Royal Exchange by Her Gracious Majesty, on the 28th October 1844*, lithograph, published by Ackermann & Co., 1844, City of London Corporation.

gathered in their thousands like ants on the street and in the stands constructed for the day. In the 1844 view confidence in the grand city as a bright, clean, secure and comprehensible locus for an upbeat demonstration of power and prosperity is intact. This gives way in

Logsdail's picture, nearly fifty years later, to a more ambivalent view.

Logsdail shows us prosperous citizens but poverty is evident, mingled in among the array of smart bonnets, neat jackets and silk hats. On the right an urchin retrieves a top hat that has been knocked into the wet street, either intending to purloin it or to return it. To the side of him an elderly woman with sunken cheeks, sharp features and rough shawl holds something white that has been drawn out of her cloth bag. Could it be bread? The plaintive look of the youngster at her side is directed at the viewer of the picture as if in appeal. This figure has his/her hand gripping the body close to the waist, deep shadows under the eyes and downturned sensitive mouth. These three figures are grouped together

thematically as 'poor and needy', yet their looks and actions do not work in concert. They are the most prominent of the 'onlookers' but they give no more indication of delight and admiration in relation to the occasion than the dog who has strayed onto the route of the procession. That dog sways and shivers in an open space where reflections of the gilded coach shimmer confusingly on the road surface.

On the other side of the road well-dressed young women are shoulder to shoulder with working families. One gentleman (to be seen between the second and third groom at the front of the procession) has his top hat ignominiously crushed by the hand of a ruffian behind him. An urchin steals oranges from the basket of a street vendor right under the elbow of a policeman in the left foreground while the policeman is spreading his arms, trying to hold the crowd back.

The markers of authority in Logsdail's picture are not aggrandised and indisputable like the figure of Wellington in Ackerman & Co.'s lithograph. For all the gold-thread embroidery, braid and fringing, the footmen and groom at the forefront of the procession are anti-heroic types, short in their stature. Receding chins, puffy eyes and callow faces make their grandiose gestures ridiculous. Logsdail even goes so far as to rhyme their movements with the most degraded and absurd components of the scene. The dog's hind legs match the footman's attempt at contrapposto. The outstretched banjo of a black-face musician on the far pavement, and his scruffy white get-up, echo the outstretched ceremonial staffs and white knee-breech liveries of the Lord Mayor's entourage. The police whether mounted on right or on foot on left do not fully control the scene, as we have seen. As for the mayor, he is just visible, rather pale and shrunken inside the bulbous, gold encrusted carriage.

It may be that we should read his presence as benign, however, given the special circumstances of the Lord Mayor's procession that Logsdail has chosen to portray.

The ceremony of 1888 was not like every other Lord Mayor's parade that had been held annually on 9<sup>th</sup> November since the sixteenth century. This is due to the fact that the incoming Mayor in 1888, Sir James Whitehead, had chosen to reduce the scale of the event drastically, enabling him to divert funds to the poor and needy in the East End. Instead of one centralised spectacle in the form of the annual parade, Whitehouse wanted to remove what he termed 'the circus element' and serve nourishing beef soup to thousands of impoverished east enders. He was a Liberal merchant who had operated in Yorkshire, and was associated closely with the democratising effects of the Penny Post, erecting a statue to Rowland Hill, and in 1879 founding a charity, the Rowland Hill Fund, for postal workers and their dependents in need. Such a link with a networked communications technology is relevant for a discussion of the pictured parade in terms of this exhibition's



Fig. 4, Walery, *The Rt Hon The Lord Mayor* (Sir James Whitehead, 1st Bt), carbon print (London: Sampson Low & Co., October 1889), NPG Ax38303 © National Portrait Gallery, London

themes. The exhibition 'Victorians Decoded' has a focus on telegraphy and this particular section of the exhibition highlights 'Transmission'. Whitehead undertook a whole range of democratising activities. He founded the 'penny-a-week' collections in factories as part of the Hospital Saturday Fund to enable the poor to access metropolitan hospitals; he encouraged education in fruit and orchid growing for cottage gardens. He served on the boards of asylums and hospitals.

We can envisage the procession itself as a transmission system for tradition. Evidence of mercantile splendour (prosperity linked to authority) is at its core, to be carefully insulated from the surrounding urban fabric and folk by a doughty police cordon. We can recognise that Whitehead was trying to puncture the insulation. He wanted the gold to seep out. To express this in terms of a telegraphic metaphor, the traditional message may not have been conveyed so effectively, but the charge could accumulate in the wider environment of the city. Whitehead's experiment was not repeated. The press reports were mainly critical of the slimmed-down parade. 'Opinions differ as to the advisability of the step the new Lord Mayor has taken in curtailing the annual November Show of so much of its attractiveness' said one rather starchily.<sup>2</sup> Logsdail's picture shows the leakage and arguably endorses it. That black-face minstrel is surely a reference to the 'circus' that Whitehead was seeking to displace. The minstrel's inclusion is a critique of the trappings of the traditional parade and a demonstration that the barriers between show and audience were permeable. The piece of bread held by the old woman perhaps alludes to the charitable dole offered by Whitehead.

The prominent presence of the poor and the depiction of active police alongside the City of London participants in the parade keys us into another aspect of this historical moment. In the period from late 1887 to late 1888 the police, particularly the commissioner of the Metropolitan Police Charles Warren, and the Home Office were under extreme pressure due to high visibility of the unemployed and the fallout following violent action against socialist demonstrators in Trafalgar Square where orchestrated attacks on demonstrators by 2000 police and 400 troops resulted in two demonstrators receiving mortal injuries on November 13<sup>th</sup> 1887, the day that came to be called Bloody Sunday, and the slaughter in a follow-up demonstration of protestor Alfred Linnell.<sup>3</sup>

The newspaper *The Star*, in November 1888 spoke bitterly of the incompetence of Sir Charles Warren and Home Secretary Henry Matthews, saying 'We remember Trafalgar-square, and the danger of fresh assaults on the unemployed this winter'. What really stoked up anger against the police in 1888 was that during 1888 as many as five murders had been carried out in the East End and the police had failed to catch the murderer known as Jack the Ripper. Whitehead went ahead and offered a reward for the capture of the Ripper whereas the police and Home Office were criticised for



Fig. 5, Herbert Rose Barraud, *Sir Charles Warren*, carbon print (London: Richard Bentley & Son, 1888), NPG Ax5432. © National Portrait Gallery, London



refusing to offer a reward. Sir Charles Warren, reportedly excessively proud of his gold-embroidered dress uniform and preoccupied with providing military-style clothing and equipment for the police, was accused of failing to search the crime scenes promptly and failing to deploy bloodhounds, reportedly losing the hounds at one point. The stray dog in Logsdail's picture is not a bloodhound but may tangentially allude to the question of police competence or incompetence. According to *The Star*, at the Lord Mayor's parade of 1888 there was a general condemnation of the police: 'there is but one cry from Tory and Liberal - "WARREN must go." At the Show yesterday his name was execrated from Aldgate to Pall Mall. He has become impossible. He is doomed'.<sup>4</sup>

The particular reason that his name resonated in this way on the day of the parade was that the Whitechapel murders were ongoing and unsolved. One mounted official in elaborate red uniform was wrongly taken to be Charles Warren and was mobbed for the length of the parade. Indeed a fifth victim of Jack the Ripper had been found in her home in Spitalfields on the morning of 9<sup>th</sup> November 1888. Long-term frustration with the lack of progress in the investigation bubbled over. Warren did in fact resign just prior to the murder but the fact had not been reported. Poignantly Mary Kelly, the victim, had said that she hoped the weather would be good the following day because she aimed to go to the Lord Mayor's parade.<sup>5</sup> *The Star*, having invoked Bloody Sunday and railed at police incompetence offered a chilling suggestion. Perhaps the murderer staged this Mary Kelly murder as a deliberate counter-demonstration to the pomp of the Lord Mayor's Show.

So he decided to get up a counter-demonstration to the LORD MAYOR'S Show. If that was his intention he succeeded beyond all expectation. He got his sensation. While the well-stuffed calves of the City footmen were being paraded for the laughter of London, his victim was lying cold in a foul, dimly-lighted court in Whitechapel. Whitechapel is once more to the fore - a grim spectre at our shows and banquets.<sup>6</sup>

We can look at Logsdail's picture and see the group to the right as just such a spectral presence, 'Whitechapel to the fore'. On the opposite side of the road the minstrel's applied black face-paint and frilled costume is the object correlative of the respectable but false glitter and pomp. Just to the left of the minstrel is another painted face that reinforces the idea that Logsdail's picture, despite offering a contrast between ceremonial and quotidian aspects, subversively allows for leakage between these categories. This painted face is that of a young woman with too much rouge. On the 9th November 1888 such a figure might well suggest the presence of a prostitute, indeed it can be taken as the spectral presence of Mary Kelly who sadly never had the chance to attend the Lord Mayor's Show.

1. It had rained overnight, was overcast by 11.00 am and maximum temperature was 46.3 degrees F. Casebook: *Jack the Ripper*, <http://tinyurl.com/2escw6> (consulted 8 September 2016).
2. *St. Stephen's Review* (10 Nov 1888), p. 15.
3. Bloody Sunday reported on by William Morris 'London In A State of Siege', *Commonweal*, volume 3, no. 97 (19 November 1887), pp. 369-70, reprinted in William Morris, *Political Writings: Contributions to Justice and Commonweal 1883-1890*, ed. and intr. by Nicholas Salmon (Bristol: Thoemmes Press, 1994), pp. 302-6. See also John Charlton, 'London, 13th November 1887' *Socialist Review*, Issue 224 (November 1997), <http://tinyurl.com/jqv174v> (consulted 8 September 2016).
4. 'Another awful tragedy in the East-End', *The Star* (10th November 1888), n.p. [p. 2].
5. 'Mrs. Prater, who occupies a room in 26 Dorset street, above that of the deceased stated that she had a chat with Kelly on Thursday morning. Kelly, who was doing some crochet work at the time, said, "I hope it will be a fine day tomorrow, as I want to go to the Lord Mayor's Show." "She was a very pleasant girl," added Mrs. Prater, "and seemed to be on good terms with everybody. She dressed poorly, as she was, of course, badly off". *Daily News* (10 Nov 1888), <http://tinyurl.com/jjca4rg> (consulted 8 September 2016).
6. *The Star* (10 Nov 1888), n. p. <http://tinyurl.com/hpeczun> (consulted 8 September 2016), also referenced in L. Curtis, *Jack the Ripper and the London Press* (London and New Haven: Yale University Press, 2008), p. 192.

TRANSMISSION

# CAROLINE ARSCOTT

ENGINEERING AND ORATORIOS: POYNTER'S ISRAEL IN EGYPT



Fig. 1, Edward John Poynter, *Israel in Egypt*, 1867, Guildhall Art Gallery, City of London Corporation.

Edward John Poynter's *Israel in Egypt*, exhibited at the Royal Academy in 1867 (no. 434) shows a team of captive Israelites shifting a vast sculpted lion by means of a wagon. They are taking the sculpture, representing Sekhmet, the Egyptian goddess of destruction (by tradition a blood-coloured and ferocious lioness) into the enclosure. The sculpture will be set alongside other identical sculptures.<sup>1</sup> The Israelites are driven on with whips by the overseers under the guiding eye of the Egyptians who have enslaved them.

The painting was exhibited with an abbreviated Biblical text:

Now there arose up a new King over Egypt which knew not Joseph, and he set over Israel taskmasters to afflict them with Burdens. And the Egyptians made the children of Israel to serve with rigour. All their services wherein they made them serve was with rigour.

Exodus, I: 8-14

In creating a work on such a large scale with a Biblical text attached, Poynter demonstrated his ambition to make highly serious art that established a dialogue with the category of history painting. The picture can in some ways be seen as a work of historical genre rather than history painting proper because it shows an everyday scene set in a historical period, rather than a key historical juncture, such as a battle or recorded act of heroism. This is in conformity with his painting *The Catapult*, exhibited at the Royal Academy one year later in 1868 (Newcastle, Laing Art Gallery). That picture partly reprises the figure of the nude Israelite placed against the back wheel of the vast wagon in its figure of a nude Roman soldier bracing his knee against the wheel of the siege machine. The Israelite pulls at the wagon with his arms and pushes with all his strength against the ground with his outstretched leg. The Roman soldier pushes the crank, or windlass, of the siege machine upwards with his right arm and pulls down on another spoke with his left

arm, obtaining leverage via his knee. In each case the nudity of the figure is a knowing invocation of academic history painting's focus on the ideal male nude. Poynter establishes some distance from that tradition though by making his athletic nudes anonymous and part of a collective effort where individuals contribute their energies to a great orchestration of forces.<sup>2</sup> The mechanical devices and expenditure of physical effort being shown in each of these pictures generalise the subject to work itself in its scientific definition: the transfer of force through distance.<sup>3</sup> Indeed Poynter first developed the composition in a drawing society project where the designated topic was 'Work'.<sup>4</sup>

The relationship of the individual unit to the system, or the particle to the field was an important aspect of the scientific investigation of energy. The popular work on energy theory, William Robert Grove's *The Correlation of Physical Forces*, was reissued in a revised fourth edition in 1862. If mechanical movement can be discussed in terms of work done against resistance through a certain distance (for instance raising a 15-stone Egyptian man on a rope against the force of gravity for a distance of forty foot) then -- according to mid-Victorian theories of energy -- heat, light, sound, magnetism and electricity should also be explained in terms of 'motions of ordinary matter'. Grove discusses the vibrations of molecules and their re-spacing in instances of heat, the reconfiguration of crystalline structure in response to pressure, the mobility of molecules in instances of chemical decomposition as well as the wave motion in particles that can be inferred in the case of sound, light and electricity. He concludes that each form of energy can be converted to another form and that the occurrence of one form of energy can be accompanied by the arising of other forces simultaneously, as in the case of electricity and magnetism where 'when electrified a substance becomes magnetic in directions at right angles to the lines of electric force'.<sup>5</sup> Field theory, in physics, saw lines of forces extending through three-dimensional space and attended to the phenomenon of criss-crossing lines associated with different forms of energy.

For the purposes of telegraphy, particularly, it was important to establish standardised ways of measuring current and resistance. The Edinburgh-based physicist William Thomson made a break-through in 1853 when he constructed a machine for measuring current based on the assumption that, as Crosbie Smith puts it in *The Science of Energy*,

The mechanical effect given out or taken in by an electrical system was precisely analogous to the work done or work absorbed by a waterfall or heat engine. In the electrical case, potential was analogous to the height of a waterfall or the temperature of a boiler, while quantity of electricity was analogous to mass of water or quantity of heat.<sup>6</sup>

Just as physicists investigating electricity and magnetism looked to models of machines to facilitate an understanding of non-mechanical forces, so Poynter could look to a primitive mechanical device (a waggon dragged by means of ropes) to elaborate a vision of work and energy as manifest in the modern world. Poynter shows us that work depends on concerted effort. Individual morality does matter (an individual act of mercy is shown in the foreground where a drink is being given to a fallen Israelite, the force of goodness barely fending off the savage intervention of the lowering overseer) but individuality is subordinated to the overall play of forces.<sup>7</sup>

In the modern world democratic systems and popular culture could be imagined as consolidating the many into a singular entity. In the modern world all kinds of physical substance were known to be susceptible to being put into motion by forms of energy. There was found to be a pervasiveness of matter and 'democratic' unity between solids, liquids and gases wherever you looked in the universe. Modern energy theory proposed that distinct forms of energy could be swapped about, as heat was changed into light for instance, or vice versa. In the modern world the transmission of telegraphic messages by means of electricity appeared to shrink distance and bring separated entities together instantaneously.

Poynter paints a picture where the role of individuals is minimised. He also compiles a number of recognisable topographical features from different locations and different periods of Egyptian history. The Great Pyramid from Giza, the Temple and other buildings from Philae, the Obelisk from Heliopolis sit alongside the Pylon gateway from Edfu. Items from the British Museum collections are brought together with some suggested by the Egyptian Court at the Crystal Palace Sydenham.<sup>8</sup>

The long narrow format of *Israel In Egypt* emphasises the shifting of the burden in a lateral direction. The action is lateral in the main, like the frieze histories of battle and gods and rulers painted on the pillars of the gateway. Indeed the overall colouration, and the discrepancy in scale between humans and sculpted lions, makes the scene of struggling Israelites seem like one of those paintings on the pylon gateway come to life. The horizontal emphases are complemented by vertical obelisk, pillars, poles and palm trees. Far in the background painters of the colourful wall decorations descend from the parapet on ropes to complete their work. This inclusion might be thought of as a playful form of self-reference for Poynter's own three-year labours on this vast work. The geometry of the whole picture is completed by criss-crossing orthogonals: peacock fans cut regularly across spears on the left, setting up the pattern; workers' limbs and crosspieces on wheels distribute this pattern across the picture. The handle of the little whip held by the Egyptian noblewoman's boy in the sedan chair on the left closely matches the orthogonals of the whip handles held aloft by overseers further forward in the train.

That boy seems to be internalising (through playful imitation) the cruelty of the enslaving forces, growing up to be a cruel Pharaoh in his turn. However the Biblical context also invites us to identify the woman as Pharaoh's daughter Bithiah in which case the boy represents the infant Moses rescued by her from the Nile.<sup>9</sup> His raised rod should be understood as a foretelling of vengeful reprisal then, against the Egyptians. He will visit plagues on the Egyptians and raise his rod to part the Red Sea only for it to crash down and drown the pursuing Egyptians. Poynter produced illustrations for wood engravings in Dalziel's Bible Gallery in 1881, many featuring Moses, including a violent scene where Moses seizes a hammer to stove in the head of the overseer at the Egyptian brickworks.<sup>10</sup> The overseer's head has been hurled onto the stack of bricks, and is almost buried in the structure, smashing through individual bricks even before the hammer is deployed. We should not expect the boy Moses to be shown by Poynter as a gentle and forgiving figure.

The title of the picture *Israel In Egypt* would have been well-known to Victorian viewers as the title of the Handel oratorio composed in 1738 (revised 1756). The phrases from the Bible verses reproduced by Poynter correspond closely to the words used by Handel in the oratorio. In the Victorian period Handel's *Israel In Egypt* was performed regularly on the third day of the Triennial three-day Handel festivals at the Crystal Palace, Sydenham.

These hugely popular, large-scale festivals were established in this form in 1859. *Israel In Egypt* followed *Messiah* which was performed on the first day and a Handel selection presented on the second.<sup>11</sup> There were 4,000 performers in 1865 and the audience for the event numbered up to 100,000.<sup>12</sup> Since participants were assembled from over 120 towns and cities across the country it was lauded as an unprecedented feat of organisation and coordination. It was a marvel when the loyal words were uttered in unison:

how, with such military discipline, they were at a given moment marshalled in regular order within an enclosed space?—how, in obedience to the signal from a solitary conductor's stick (even though that conductor was Mr. Costa), they instantaneously and simultaneously shouted "God Save the Queen" as though they had been shouting it in concert from time immemorial.<sup>13</sup>

The dispersal (and potential for opposition) of geographically separated entities was replaced with ideologically reassuring, simultaneous presence. Thanks to railways, postal services and the military precision of Michael Costa the far-flung came together to deliver thunderous choruses. The thrill produced by the festivals' condensation of time and space echoes the fantasies attaching to a world transformed by telegraphy.

I suggest that with his painting Poynter had the oratorios in mind and sought to achieve grandeur and stunning scale comparable to that of the Handel festivals. The Handel piece itself spans the years of enslavement, the plagues unleashed by God on the Egyptians via Moses, the miraculous crossing of the Red Sea and the destruction of the pursuing forces. It astounds listeners with the might of a punitive God. It ends with dancing and praise to the Lord by Miriam, together with other Israelite women, bearing timbrels or tambourines.<sup>14</sup> Poynter includes figures who, I suggest, stand for this group in the right foreground of his picture.<sup>15</sup>

The *Art Journal* commentary on this picture in 1869 comments on the ‘pull’, ‘pluck’ and ‘spirit’ of the figures and the ‘action’, ‘motion’ and ‘force’ depicted.<sup>16</sup> Poynter’s picture was itself a rousing performance. With some adjustments to satisfy the technical calculations made by the purchaser (with respect to the number of men required to pull such an object) the painting of Ancient Egyptian labour went into the collection of the engineer Sir John Hawkshaw, actively involved in modern-day Egypt as a consultant and keen advocate of the construction of the Suez Canal. The final phase of construction was from March 1864 - November 1869, coinciding with the period in which Poynter worked on the picture and its initial reception in the art world. Hawkshaw was President of the Institution of Civil Engineers in 1862. In his address of 1862 he claimed outright that, with the railways, electric telegraph, and steam navigation, modern engineering had annihilated both space and time. This exhibition shows that such claims were commonly made. Such achievements depended on multiple skill sets, Hawkshaw argued: both science and art were important, but along with these specialisms, not to be forgotten were the ‘strength and skill’ of a ‘great variety of workmen’.<sup>17</sup> Many commentators on the Suez Canal and on the telegraph links of the world compared them in scale and significance of Egyptian building projects.<sup>18</sup>

The ideology of mass participation marked the enthusiasm for the Handel festivals. Such an ideological position is a defining feature of Poynter’s picture too. Energy transmission and the collapse of time and space could be adopted as topics for a history painting in view of the definitions of work and energy emerging from the physics and engineering in the 1860s. A close reading of Poynter’s idiosyncratic history painting indicates that with the enthusiasm for modern communications came a focus on the common man, as one unit repeatable thousands of times, but essential en masse as components for the transfer of force.

1. *Athenaeum* (11 May 1869), p. 628 mentions that the lions were the ones brought to Britain from Nubia by Lord Prudhoe in 1828. They have been located in the British Museum since 1835. The pair of red granite lions from the period of Amenhotep III were studied by Poynter; the British Museum holds a blue chalk sketch by him of one of the lions, <http://tinyurl.com/h9acfln> (consulted 10 September 2016).
2. I have argued that *The Catapult* effectively constitutes a force field as understood in the emerging science relating to the interaction of electrical force and magnetism. The scientist Michael Faraday's proposal that lines of force extend through space was systematised by the physicist James Clerk Maxwell in a four-part publication 'On Physical Lines of Force' 1861-2 which imagined spinning of cells on axes, interspersed with particles acting like idle wheels or ball bearings in a mechanism. He used this idea to establish the difference between the effects of electricity on conductors, where the 'idle wheels' moved freely, and non-conductors where the 'idle wheels' simply rotated in place. His model allowed him to establish that electricity, magnetism and light were related phenomena all acting with wave motion. Caroline Arscott, 'Poynter and the Arty' in E. Prettejohn (ed.) *After the Pre-Raphaelites* (Manchester: Manchester University Press, 1999), pp. 135-151. For a summary of Maxwell's argument see Basil Mahon, *The Man Who Changed Everything: The Life of James Clerk Maxwell* (Chichester: Wiley, 2013), pp. 90-110.
3. 'Work done varies as the resistance overcome and the distance through which it is overcome conjointly', 'ENERGY', *Encyclopaedia Britannica*, 1911 edition, ed Hugh Chisholm (Cambridge: Cambridge University Press, 1910-22), vol. 9, p. 398. For the significance of emerging literature on energy referencing P. G. Tait 'Historical Sketch of the Science of Energy' (1868) and W. Garnett in 9<sup>th</sup> edition of *Encyclopaedia Britannica* (1879) see Crosbie Smith, *The Science of Energy: A Cultural History of Energy Physics in Victorian Britain* (Chicago: University of Chicago Press, 1998), p. 2.
4. Poynter first devised the subject when the theme 'Work' was proposed at the Langham Sketch Club in 1866, Cosmo Monkhouse, *Sir Edward J. Poynter His Life and Work* (London: J. S. Virtue, 1897), p. 10.
5. William Robert Grove, *The Correlation of Physical Forces* (1846), 4<sup>th</sup> edition (London: Longman, Green, 1862), p. 242.
6. Crosbie Smith, *The Science of Energy: A Cultural History of Energy Physics in Victorian Britain* (Chicago: University of Chicago Press, 1998), p. 273.
7. Another bearded figure is dispensing drinking water to the suffering Israelites. He is positioned at the far side of the work gang at the turning point of the procession. This faintly-depicted figure resembles a figure of Christ. The left-to-right trajectory within the elongated picture might therefore be considered to be from Mosaic law to Christian redemption. The picture compresses Biblical time.
8. These identifications were made by Patrick Conner in the Introduction to *The Inspiration of Egypt: its influence on British artists, travellers and designers, 1700-1900*, exh. cat. (Brighton: 1983). The reviewer in *Art Journal* (June 1867), p. 139 registers that the lions were found 400 miles from the Great Pyramid.
9. This is the identification offered in the short web article by Nathan Karp, 'Sir Edward John Poynter's *Israel in Egypt*: Experimenting with the Orient' (2007), <http://tinyurl.com/hgebvzx> (consulted 10 September 2016).
10. After E. Poynter, 'Moses Slaying the Egyptian', engraved by Dalziel Brothers for *Dalziels' Bible Gallery* (New York: Scribner and Welford, 1863-81), <http://tinyurl.com/zl4rs45> (consulted 10 September 2016).
11. <http://tinyurl.com/jsrugd6> (consulted 10 September 2016).
12. <http://tinyurl.com/zyxyrfd> (consulted 10 September 2016).
13. 'Never was vast undertaking so admirably organised. The 4,000 singers and players seemed to get in and out of their places,—day after day, at the rehearsal and at the three successive performances,—as if by magic. We wonder if any among the thousands attracted on each occasion asked themselves how and by what means such a formidable host of executants ever came together?—how, with such military discipline, they were at a given moment marshalled in regular order within an enclosed space?—how, in obedience to the signal from a solitary conductor's stick (even though that conductor was Mr. Costa), they instantaneously and simultaneously shouted "God Save the Queen" as though they had been shouting it in concert from time immemorial? Upwards of 120 towns and among them 32 cathedral or collegiate cities sent delegates to the Handel-Festival Orchestra, which both in its vocal and instrumental departments was the largest and most splendid ever assembled. Had their united performance been merely tolerable there would have been sufficient cause for surprise; that it was for the most part admirable trenches on the marvellous', *The Tablet* (5 Jul 1862), p. 13.
14. 'And Miriam the prophetess, the sister of Aaron, took a timbrel in her hand; and all the women went out after her with timbrels and with dances. And Miriam answered them:— Sing ye to the Lord, for He hath triumphed gloriously; the horse and his rider hath He thrown into the sea.' The words of the Oratorio are attributed to Charles Jennens, <http://tinyurl.com/z9kw5up> (consulted 10 September 2016).
15. This represents another act of temporal compression within Poynter's canvas from the infancy of Moses to the liberation of the Israelites.



16. *Art Journal* (June 1867), p. 139.
17. Sir John Hawkshaw address 1862 reported in *Leisure Hour* (28 Aug 1875), p. 559.
18. For example: 'The *Great Eastern* has just been engaged in successfully laying a cable through the Red Sea, which has thus witnessed one of the great wonders of modern civilisation even as it did in Pharaoh's day, one of the greatest of ancient times. *Albion* (12 March 1870), p. 9.

## TRANSMISSION

## CASSIE NEWLAND

## TELEGRAPHIC COPPER

Before the advent of the telegraph, copper wire was produced solely for mechanical purposes. The main consumer was the women's hat-making industry.<sup>1</sup> To avoid sharp ends sticking through the expensive and delicate fabrics, the wires were closely wound in silk or cotton thread. These wrapped wires were known as 'bonnet wire'. When the early electrical engineering pioneers, for example Charles Wheatstone or Michael Faraday were looking for sources of insulated wire they turned to readily available bonnet wire.<sup>2</sup> The existing hand-wound bonnet wire industry was initially able to meet demand but as the electrical engineering sector grew a larger scale solution was required. William T. Henley was an early pioneer who had set up shop as a maker of electrical equipment using bonnet wire. Recognising the growth in demand for wrapped wire Henley developed a 'six head wire covering machine' which he patented in 1837: the same year as Cooke & Wheatstone's first telegraph line was laid. Henley was not the only scientific instrument maker cashing in on the demand for bonnet wire. Mills notes that the respected instrument firm Watkins & Hall were also advertising bonnet wire in their 1838 catalogue.<sup>3</sup>

Early telegraph wires, such as that manufactured at Henley's Telegraph Works, had an irregular, elliptical cross section.<sup>4</sup> This is an artefact of the process of making wire. A rod of cold copper is pulled through a hole in a metal plate of smaller diameter, stretching it, rounding it and reducing it in size. This is done several times using ever smaller holes to achieve the thickness of wire required. If the plate is not entirely perpendicular to the direction of pull the resulting wire is slightly oval in cross section. Unbeknown to early telegraph engineers an elliptical cross section impacts badly on the carrying capacity, frequency, working distances, insulation requirements and electrical performance of a wire. The first attempts to explore these erratic performances came in the 1850s when the stakes were raised by the largest-scale telegraph project of them all: the Atlantic Cable.

In 1857 Professor William Thomson gave a lecture to the Royal Society in which he identified the purity of copper as a potential source of problems. When Thomson analysed the copper cable being produced by four leading manufacturers he found that even the worst performing wire was over 99.75 per cent pure and concluded that 'very slight deviations from perfect purity must be sufficient to produce great effects on the electric conductivity of copper'.<sup>5</sup> After Thomson's investigations, impurities in copper were widely blamed for the variable performance of telegraph and other electrical equipment. Thomson was so convinced of the connection between small impurities and falls in conductivity that in the late 1850s he led a call for copper smelters to improve the purity of their product. He succeeded in having a minimum standard for the purity of copper written into the specification for the 1865 and 1866 Atlantic cables. After the success of the operation 'high conductivity copper' became standard on all new cable schemes.

The purest copper in the world was smelted in Chile and was shipped in the form of best 'picked' or 'selected' 'chili bars' (sic). The 'chili bar' had been established in the 1840s to provide an international standard product for export. They were six inches long by two inches square (15 x 5.8cms) and of a standard purity.<sup>6</sup> It was the engineers' product of choice, consistently of 'high quality and abundance'.<sup>7</sup> Chili bars could be bought at 96-97 or 99 per cent fine copper.<sup>8</sup> Only copper with the highest purity available was used in the manufacture of telegraph wire. Chile had been exporting processed copper since the 1830s when reverberatory furnaces had been introduced from Swansea.<sup>9</sup> Copper must be smelted (baked but not melted) to remove other minerals from the desired metal. The copper of found in Chile had a particularly easy composition to smelt and few stubborn impurities. Smelting of chili bars in Chile itself really took off in 1842 when trade tariffs made the export of raw, un-smelted ore uneconomic.<sup>10</sup> From these beginnings Chile rose to become one of the world's biggest exporters of copper exploiting many mining districts and establishing an increasing number of copper smelting operations.

The Chilean smelting industry was dominated by a few, large factories. Smelting operations were established in the 1840s and 1850s at Guayacán, Coquimbo and Tongoy, and Tamaya in the north; and at Lirquén and Lota in the south.<sup>11</sup> The refineries at Guayacán and Tongoy were owned by the Urmeneta Y Errázuriz Company (hereafter known as Urmeneta), which by 1860 had become established as Chile's largest smelting concern. Urmeneta's 'chili bars' were considered to be of the very highest quality. When the market price for 'good' 'chili bars was £67 per ton, those smelted at Urmeneta commanded £68.<sup>12</sup> Guayacán, in particular, concentrated its efforts on supplying a greater percentage of the highest quality bars for use in the telegraph industry.<sup>13</sup>

Chile's access to the world copper market was mediated by international brokers and commission houses who exercised substantial control over the industry. They bought Chilean copper and set the market rate. They exported the copper and charged commission on all copper sold. They also filled the role of financiers, lending money to the smelting firms, with repayments to be made in copper for export. Interest rates appear to have been between eight and twelve per cent per annum.<sup>14</sup> The London-based commissioning house of Gibbs & Co contracted the Urmeneta company to supply them with copper on an exclusive basis.<sup>15</sup> Gibbs & Co exported Urmeneta 'chili bars' to the UK in Barques. Barques were ships specially built for the Cape Horn run between the UK and Chile, and known colloquially as 'Cape Horners' or simply 'Horners'. A typical copper barque, such as *The Zeta*,<sup>16</sup> was fully rigged, constructed of iron and (from the 1870s) fitted with a steam engine.<sup>17</sup> Like all barques, *The Zeta* was designed to cope with the densely heavy copper cargoes it would carry and was fitted out to operate in Chile's basic coastal ports. On the outward journey, anthracite coal was exported from Swansea to Chile to be used in smelting. The barque would then make the return journey carrying raw ore for processing

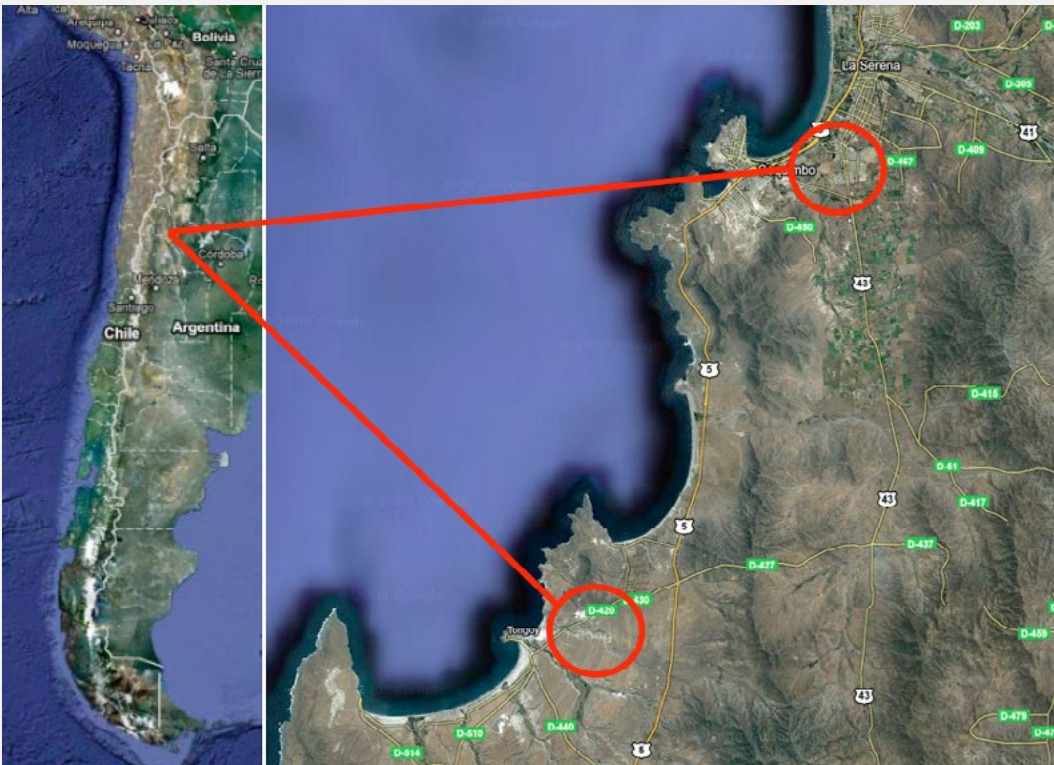

Fig. 1, Map of Chile showing location of smelting works at Guayacán (top) and Tongoy (bottom). Google Maps, 2010, with overlay by author.

at Swansea and fully refined ‘chili bars’.

Once the high purity ‘chili bars’ hit the shore they would be bought up by one of the leading companies in the emerging field of conductivity copper, such as the Birmingham based firm of Bolton & Sons. Bolton & Sons were asked to manufacture the copper core for the first cross-channel cable in 1851. The copper core was revolutionary: the first attempt to manufacture wire in continuous, 500 yard lengths (80 yards was standard). Indeed, Moreton notes that when the factory foreman was notified of the order he responded ‘does the man take me for a fool?’.<sup>18</sup> The Atlantic cable succeeded on the second attempt and this event appears to have inspired the managing director’s son, Alfred Bolton, to rebuild and re-equip the factory with the plant necessary to supply the great lengths required by the burgeoning telecommunications industry. A year later Alfred Bolton took on a large site in the Churnet Valley: Oakamoor.<sup>19</sup> It was at this site that Moreton argues ‘the main contributions to copper-making and the electrical industry were made’.<sup>20</sup>

Business boomed and in the first five months of the Oakamoor factory opening it had manufactured 55 tons of copper wire exclusively for the telegraph industry. Many of the larger cable orders, such as that for the Atlantic cables of 1865 and 1866, required such

huge lengths of cable in such short order that collaboration between several companies appears to have been fairly standard across the industry. Alfred Bolton's close working relationship with the noted telegraph engineer William Preece did much for the firm's reputation and ensured that Bolton & Sons remained at the leading edge of telegraph copper making.<sup>21</sup> It was at their manufactory at Oakamoor where the next big breakthrough in high conductivity copper was made.

The conclusions that Thomson had made back in 1858 - that small impurities have large electrical effects - although true, was not the whole story. As copper smelters and wire manufacturers strove for ever greater purity of copper, their wires still failed to live up to their mathematically projected conductivity. In 1861 the government commissioned a report from respected chemist and physicist Augustus Matthiessen. Matthiessen carried out extensive tests which supported Thomson's observations on purity and conductivity but also highlighted a previously unknown problem: oxygen contamination. During the drawing process, where wire is pulled through successively smaller holes, oxygen bubbles from the air become trapped inside the metal. These bubbles increased its porosity and greatly reduced its conductive properties. Bolton & Sons rebuilt the machinery at Oakamoor to take advantage of Matthiessen's new discoveries. Air was excluded from copper in a molten state, and rolling - rather than drawing - was used to turn the of cut strips of copper into wire, greatly reducing the amount of oxygen introduced into the metal. The introduction of inert gas atmospheres for wire drawing at the very beginning of the twentieth century solved this problem permanently.

The composition of wires tells us more about an artefact than just a date (approximate or otherwise). The 'bonnet wires' of early, experimental telegraphy can, for example, be seen as reflecting a period of great transition in manufacturing. The large variations in physical appearance displayed by early cables were characteristic of early-Victorian engineering systems where products were never identical, and tolerances expressed in hundredths of inches. The embryonic telegraph industry, in contrast, required an attention to detail more characteristic of the precision scientific instrument industry. Telegraphic instruments were one-off pieces crafted by men in workshops.<sup>22</sup> These two industrial traditions clashed in the development of larger, long-distance telegraphy systems. Precision-engineered materials were required on an industrial scale and there was simply no industry capable of supplying them. The internal structures and chemical compositions of the wires speak volumes about the state of contemporary knowledge in chemistry, physics and electrical engineering and about the dialogue between the theoretical and the technical within these fields. Detailed physical analysis allows us to eavesdrop on the conversation between people and materials as they negotiate new relationships on microscopic - if not invisible - scales.

1. A. A. Mills, 'The Early History of Insulated Copper Wire', *Annals of Science*, vol. 61, no. 4 (2004), p. 456.
2. T. Martin (ed.), *Faraday's Diary of Experimental Investigation*, Vol. 1 (London: Royal Institution of Great Britain, 1932), p. 367.
3. Mills, 'Copper Wire' (2004), pp. 456-7.
4. *Ibid.*, p. 460.
5. William Thomson, 'On the Electrical Conductivity of Commercial Copper of Various Kinds', *Proceedings of the Royal Society* (1857), p. 552.
6. W. Culverand, R. Cornel, 'Capitalist Dreams: Chile's Response to Nineteenth-Century World Copper Competition', *Comparative Studies in Society and History*, vol. 31, no.4 (1989), p. 736.
7. *Ibid.*, p. 736.
8. L. Valenzuela, 'The Copper Smelting Company "Urmeneta y Errázuriz" of Chile: An Economic Profile, 1860-1880', *The Americas*, vol. 53, no. 2 (1996), p. 236.
9. *Ibid.*
10. S. Collier & W. F. Sater, *A History of Chile 1808-2002* (Cambridge: Cambridge University Press, 2004), p.79.
11. *Ibid.*, p. 80.
12. Mineral Statistics, 'Mineral Statistics of the United Kingdom of Great Britain and Ireland for the Year 1871' (1871).
13. Valenzuela, 'Copper Smelting Company' (1996), p. 243.
14. *Ibid.*, p. 255.
15. *Ibid.*, pp. 255-256.
16. The Zeta was the first ordinary trading ship to run the Straights of Magellan. Its engines also came in handy when blockade running during the War of the Pacific (1879-84) (Burrow n.d.). It was also the ship that Catherine Zeta Jones is named after. Her great grandfather was the ship's captain.
17. Lloyd's Register for Ships (1875), <http://tinyurl.com/jdm2xed> (accessed 22/08/2016).
18. J. Moreton, 'Thomas Bolton & Sons and the rise of the electrical industry', *Engineering Science and Education Journal* (Feb 1999), p. 6.
19. Legend has it that his father Thomas had sent him up to buy some plant but he returned having bought the entire factory.
20. Moreton, 'Bolton & Sons' (1999), p. 7.
21. William Preece, 'On Electrical Conductors', *Minutes of the Proceedings of the Institution of Civil Engineers*, Vol. 75 (1883), pp. 67-8.
22. P. Israel, *From Machine Shop to Industrial Laboratory: Telegraphy and the Changing Context of American Invention, 1830-1920* (Baltimore: John Hopkins University Press, 1992).

## CATALOGUE ENTRY T1 | TRANSMISSION

JAMES CLARKE HOOK (1819 – 1907)

**CAUGHT BY THE TIDE, 1869**

68 X 108 cm

GUILDHALL ART GALLERY, CITY OF LONDON CORPORATION



This is one of several pictures by James Clarke Hook in the Guildhall Art Gallery collection. Four examples have been included in this exhibition. This painting was exhibited at the RA in 1869 (no. 332). At the same exhibition Hook showed two other pictures: *Cottagers making cider* (no. 124) and *The boat* (no. 217).

Hook was known for his sea scenes described as ‘wholesome, ably painted sea pieces’ by the *Art Journal* on the occasion of the Royal Academy winter exhibition retrospective exhibition of his work.<sup>1</sup> F. G. Stephens described the way that his pictures restored jaded city viewers by bringing them in imagination to the sea, offering ‘vigorous and wholesome provisions of the sunlight and the shores.’<sup>2</sup> His coastal scenes were set in Scotland, Yorkshire, Devon, Cornwall and Scilly as well as Holland, Brittany and Norway. He was known for the poignant moods that he evoked and for what was described as the ‘super-subtle’ registration of local colour, atmospheric conditions and the effect of light, giving a specificity to whichever locale he selected.<sup>3</sup>

The picture shows a message being transmitted. The boy has attached a rag to a crab hook and waves it like a flag to attract the attention of a fishing boat out at sea. The children have been trapped by the incoming tide and hope that the boat will rescue them. They have a basket of crabs that they have gathered: showing their industriousness and their contribution to their humble community’s breadwinning efforts. Optical signalling was the precursor to the electrical telegraph. In common with other works by this artist the

picture explicitly addresses themes of communication over distance, for instance he had approached this theme in 1857 with two works exhibited in that year at the *RA: A Signal on the Horizon*, “*Her Union-Jack is at the Fore*” (no. 160) and *The Shipboy’s Letter* (no. 545).

In this 1869 picture the fear and discomfort of the boy’s sister and smaller sister (or brother) is shown in the way that they huddle, barefoot as they are, for shelter in the lee of the rock, the sister’s hair and neckerchief swept sideways by the fierce wind. The boy, by contrast, stands stoutly. His sense of family responsibility, masculine duty, bravery, confidence and ingenuity are the heart-warming aspects of the picture. The positive ethical and emotional connotations of the boy’s stance and action are associated by Hook with the telegraphic mode of communication. The picture is wholesome in its evocation of the healthy atmosphere of the coast, but also in the exemplary behaviour of this rustic child. That wholesomeness of the motif transfers across to the idea of the telegraph being beneficial and humane in the way that it overcame obstacles to enable human contact.

The picture changed hands several times in the decade from 1869, being bought by the dealer Agnew’s for the considerable sum of 1,020 guineas at the sale of Jonathan Nield of Dunster House Rochdale (Christie’s 3 May 1879) under the title *Overtaken By the Tide*.<sup>4</sup> Hook was elected to be ARA in 1850 and RA in 1860.

CA

1. ‘Passing Events’, *Art Journal*, (February 1908), p. 58. Nineteen paintings by the artist were shown.

2. F. G. Stephens, ‘English Artists of the Present Day. XXXII, James Clarke Hook, R.A.’, *Portfolio*, (January 1871), p. 181.

3. *Ibid.*, p. 186.

4. William Roberts, *Memorials of Christie’s: A Record of Art Sales from 1766 to 1896*, vol. 1, (London: G. Bell & Sons, 1897), p. 306.



CATALOGUE ENTRY T2 | TRANSMISSION

JAMES CLARKE HOOK (1819 – 1907)

# THE BONXIE, SHETLAND, 1873

74 X 112 cm

GUILDHALL ART GALLERY, CITY OF LONDON CORPORATION



This is the final picture by Hook in this exhibition. For viewers in 1873 it was strongly reminiscent of an earlier picture by Hook of a boy going down a cliff face on a rope, *The Coast Boy Gathering Eggs* RA 1857.<sup>1</sup> That picture where the descending lad hung perilously over gleaming water was fondly remembered as a highlight in Hook's career. It included a motif of signal-making since the boy indicated his altitude and signalled to his rope-holding companion with a makeshift flag on a long stick. The consistency of Hook, year after year, in presenting absorbing human activity and variegated coastal light effects was admired. In this picture, *The Bonxie*, reviewers noted the clever treatment of water, saying that the light and colour of the sky is partly reflected in the 'multitudinous mirrors' of the sea's surface and partly absorbed by the 'deep green and glass-like fluid' of the water.<sup>2</sup>

The children have formed a human chain, in order to reach the gulls' eggs on the cliff. The smaller boy is being held by his sister by the waist-band of his trousers as he leans over to seize the eggs from the nest built on a ledge. We see their egg basket, already nearly full, on the cliff top beside them. The older boy described by *The Times* as 'a gallant laddie' facing the skua gull (or bonxie) fends off the angry gull with a knife on a stick with a bonnet to protect his hand.<sup>3</sup> The telegraphic signal passed from atom to atom in the conducting core: not a human chain but a chain of copper atoms. The cable core had to be defended with insulating layers.

This picture was exhibited at the RA in 1873 (no. 254). At the same exhibition Hook showed three other pictures including *The fishing haven* (no. 20) and *Fishing by proxy* (no. 227). The *Art Journal* considered that in the course of his career he had arrived at perfection in depicting ‘the breezy, bracing brinyness of a fishing coast’.<sup>4</sup> The vivacity of his style was attributed to the combination of a systematic workmanlike approach to oft-repeated pictorial components and the ability to vary his painted touch to convey the particularity of substance, whether ‘the semitransparent undulation of a wave, the jag of a rock or the creamy curl of a wave-crest’.<sup>5</sup> In this account, dating from 1907, it is claimed that particular paint marks were devised for different phenomena. It is said that paint marks were adapted by Hook to produce ‘analogies’ to natural phenomena. This makes the work one of transmission of the real, not by means of a homogeneous description but by means of a series of discrete signals. The linkage of human actors in communication across distances or in cooperative activity (as in this painting) was the social aspect of transmission that appealed to him given his liberal political stance.<sup>6</sup> The technical aspect of his craft also involved linkage of separate points of perception in his pictorial synthesis of improvised touches.

CA

1. Etched in 1867 for the Etching Club, described P. G. Hamerton, *Etching and Etchers* (London: Roberts, 1876), p. 343; reproduced in a wood engraving, *Portfolio*, Jan 1888, p. 41.

2. ‘The Royal Academy: I’, *Graphic*, (17 May 1873), p. 467; *Athenaeum*, (3 May 1873), p. 569.

3. *The Times*, (3 May 1873), p. 12.

4. ‘Home With the Tide’, *Art Journal*, (October 1894), p. 318.

5. ‘Mr. J. C. Hook, R.A.’ *Athenaeum*, (20 April 1907), p. 482.

6. His biographer A. H. Palmer discussed his championing of working people and sympathy for the poor but felt it necessary to describe him as a ‘hearty Liberal’, adding categorically ‘anything approaching a Socialist he is not’, in ‘James Clarke Hook, Conclusion’, *Portfolio*, (January 1888), p. 169. Palmer also rejected the idea that the surface or facture of Hook’s work – or indeed that of any artist – was important, preferring instead to characterise pictures as windows on nature, *Ibid.*, p. 169.

CATALOGUE ENTRY T3 | TRANSMISSION

EVELYN DE MORGAN (1855-1919)

# MOONBEAMS DIPPING INTO THE SEA, 1900

99 X 70.8 cm

COURTESY OF THE DE MORGAN FOUNDATION



Evelyn De Morgan trained at the Slade School of Art. She exhibited at the Grosvenor Gallery from 1877 and later in the New Gallery. De Morgan produced a second smaller version of this picture in 1918 (Knightshayes Court, Devon, National Trust).

The transmission of messages was of special interest to Evelyn de Morgan due to her belief in the reality of spirit messages. Her art imagines chains of figures connecting through space and between heavenly and earthly realms. In this picture she is envisaging the phenomenon of light in terms of three life forms. The three naked female figures collectively represent a moonbeam travelling from the moon down to the sea. Rather than imagining one single allegorical figure of Luna or Lux she shows multiplied, identical figures linked together in a chain for the transmission of energy.<sup>1</sup> Light touches the surface but also passes through the liquid substance of seawater, so the toe of the lower-most figure is shown as immersed in the water.

Evelyn de Morgan was strongly influenced by the spiritualist beliefs of her mother-in-law Sophia De Morgan who had published an account of her investigations into spirits *From Matter To Spirit* in 1863.<sup>2</sup> Convinced by the religious tenets of Swedenborgianism, Evelyn De Morgan considered that efforts should be made to establish communication with spirits. She and her husband the Arts and Crafts potter and novelist William de Morgan used the techniques of automatic writing to channel the spirit messages. The couple published a compilation of spirit messages they had received. The following message was included in the book:

Loud above all earthly strains sounds the ringing music of the spheres. Pierce upwards through the dim world of undeveloped spirits, grasp the Angel hands that stretch out to you across the grey world of matterful spirit, and rise to the knowledge of growth and the Heavens of burning light.<sup>3</sup>

It indicates the way that sound waves, light rays and spirit energy were thought to combine in the communication channels between heaven and earth. The physicality of Swedenborgian ideas of the afterlife shaped the imagining of spirit communication, linking the brain fibre of the spirit with the brain fibre of the receiving earthly being.

Sophia De Morgan wrote that spiritualism was an extension of physical science: she adduces as comparative examples engineers' studies of the effects of friction on the motion of railway trains and Newton's hypotheses concerning gravity.<sup>4</sup> She alludes to the study by physiologists of the linkage between 'electric, magnetic and nervous forces'.<sup>5</sup> She repeatedly references the way that the nerves or brain fibres work like telegraphic cables.<sup>6</sup> At the core of the nerve she says is a thread 'a telegraphic cable for the transmission of the refined electricity which conveys the messages between spirit and body'. This make the entire human body into what she terms 'the human electric telegraph'.<sup>7</sup> She documented rays of light being seen passing from the hand of the person acting as a medium into

vessels of water, seeming to make the water boil or to electrocute insects in the water.<sup>8</sup> Water was special in this way, she claimed, because it could receive the spiritual current.<sup>9</sup>

This picture by Evelyn de Morgan shows the chain of allegorical figures as a conduit for a quasi-electrical spiritual force that can manifest its nature when it passes into water or into the mind of the humans on earth seeking enlightenment.

CA

1. She did on other occasions devise singular allegorical figures for the moon and light, eg *Luna* (1885, De Morgan Foundation) and *Lux In Tenebris* (1895, De Morgan Foundation).

2. Sophia Elizabeth De Morgan, *From Matter to Spirit: The Result of Ten Years' Experience in Spirit Manifestations. Intended As a Guide to Enquirers*. By C.D. with a Preface by A. B. [Augustus De Morgan] (London: Longman, Green, Roberts, & Green, 1863). See Judy Oberhausen, 'Evelyn De Morgan and Spiritualism' in C. Gordon (ed.), *Evelyn De Morgan: Oil Paintings* (London: De Morgan Foundation, 1996), and Judy Oberhausen, 'Evelyn Pickering de Morgan and Spiritualism: An Interpretative Link', *Journal of Pre-Raphaelite Studies*, New Series III, Spring 1994.

3. Evelyn and William De Morgan, *The Result of An Experiment* (London: Simpkin, Marshall, Hamilton, Kent, 1909), p. 77. The same passage is quoted in relation to this painting in Lois Jane Drawmer, 'The Impact of Science

and Spiritualism on the Works of Evelyn de Morgan, 1870-1919', Unpublished PhD, Buckinghamshire Chilterns University College, 2001, p. 216.

4. Sophia Elizabeth De Morgan, *From Matter to Spirit*, (1863), pp. xviii-xvix; p. xxiii

5. *Ibid.*, p. 96.

6. *Ibid.*, pp. 25, 33, 98, 114, 276.

7. *Ibid.*, p. 276.

8. *Ibid.*, p. 46.

9. *Ibid.*, p. 96. Sophia De Morgan notes that water is the only substance that can be acted on like this by spiritual currents, whereas many different substances can be affected by earthly electrical devices.

CATALOGUE ENTRY T4 | TRANSMISSION

FREDERIC LEIGHTON (1830 – 1896)

# THE MUSIC LESSON, 1877

93 X 95 cm

GUILDHALL ART GALLERY, CITY OF LONDON CORPORATION



A mother or older companion teaches her young charge, cosily nestled up against her, to play a kind of guitar, a Turkish instrument called a 'saz'. She tunes the instrument with one hand and squeezes the girl's forefinger gently between her own forefinger and thumb.<sup>1</sup> The malleability of anatomy and extreme softness of flesh that Leighton depicts here is modelled on the painting of Jean Auguste Dominique Ingres (1780-1867). The setting is based on buildings that Leighton observed on his visit of 1873 to Damascus. The rhythmic patterns in the pillars and inlaid marble present the visual equivalent of a spaced-out sequence of notes. The dangling legs of parent and child as well as the vertical bands of white marble on the front face of the ledge also suggest the succession of notes on a staff. The transmission of knowledge is to be achieved by steady pulsing of music backed up by the ornamental features in the environment, something like the telegraph key tapping to

transmit a message. However Leighton is as interested in the merging of identities as in the separation and repetition of elements that are essential to rhythm and ornament.

Because the adult's ankles are crossed, and due to the colour match between the adult's pale-gold baggy trouser leg and the child's similarly-coloured trouser leg, the viewer, at first glance, registers the child's left leg as belonging to the mother. The child's other trouser leg is covered over by the blue garment. This produces an unsettling suggestion of a three-legged composite figure. The effect is repeated in the arms. The intermingling of fingers and nesting of forearms draws the adult and child's right hands together as if one limb, giving the pair a total of three arms. There is a subtle play of similarity and difference in the textiles arranged along the ledge: peachy linings for gold and white silken garments, gold striped and pale golden trousers, creamy linings for the blue overgarment, toning darker blue in a golden-fringed rug just visible at the right. Various elements participate in a continuum as the colours progress from peach on left to blue on right. The peach is keyed in to the red of a flower lying on the ground to the left in the manner of the Aestheticist artist Albert Moore (1841-1893). This formal colour progression pays no heed to separation of persons or substance.

This picture was exhibited at the RA in 1877 (no. 209). At the same exhibition Leighton's most discussed exhibit was the sculpture *Athlete Wrestling with a Python* (no. 1466).<sup>2</sup> His career was thriving; acclaim for his work and its careful finish, emphasis on drawing and respect for classical academic values led to his election as President of the Royal Academy the following year. Vastly different in mood from the 'pretty charm' and delicate softness of *The Music Lesson*, his 1877 sculpture showed extreme physical effort expended in a life-and-death struggle.<sup>3</sup> A heroic male nude grasps the snake, digging his fingers into its neck to stifle it. The snake in turn, coils itself tightly around ankle and thigh of the athlete and attempts to grip and squeeze the athlete's trunk. Leighton offers a parallel between the muscular system of the athlete's right arm and the muscular organization of the snake's body that runs along it. Snake and man become a composite being like the adult and child of *The Music Lesson*. In terms of the combat they are opposites but, as they interact, the difference becomes minimal.

In telegraphy the clarity of signalling depended on maintaining a rhythm and tempo that kept elements separate, but due to the process of transmission the patterns could become delicate or muffled. Instruments were devised to register extremely small variations. Leighton in *The Music Lesson* appears to be meditating on minimal difference and the borderline between maintenance of identity and the merging of identity.

1. For a discussion of the two figures see Caroline Arscott, 'Leighton: The Artist as Artificer'; in T. Barringer and E. Prettejohn (eds.), *Frederic Leighton: Antiquity, Renaissance, Modernity, Studies in British Art 5* (New Haven and London: Yale University Press, 1999), pp. 3-17.
2. Frederic Leighton, *Athlete Wrestling with a Python*, bronze, 1877, London, Tate, <http://tinyurl.com/hs8zxzz> (consulted 15 September 2016).
3. M. H. Spielmann, 'The Leighton Exhibition', *Graphic* (9 January 1897), p. 38.



CATALOGUE ENTRY T5 | TRANSMISSION

FRANK WILLIAM WARWICK TOPHAM (1838 – 1924)

# *RESCUED FROM THE PLAGUE, LONDON, 1665, 1898*

183 X 114 cm

GUILDHALL ART GALLERY, CITY OF LONDON CORPORATION

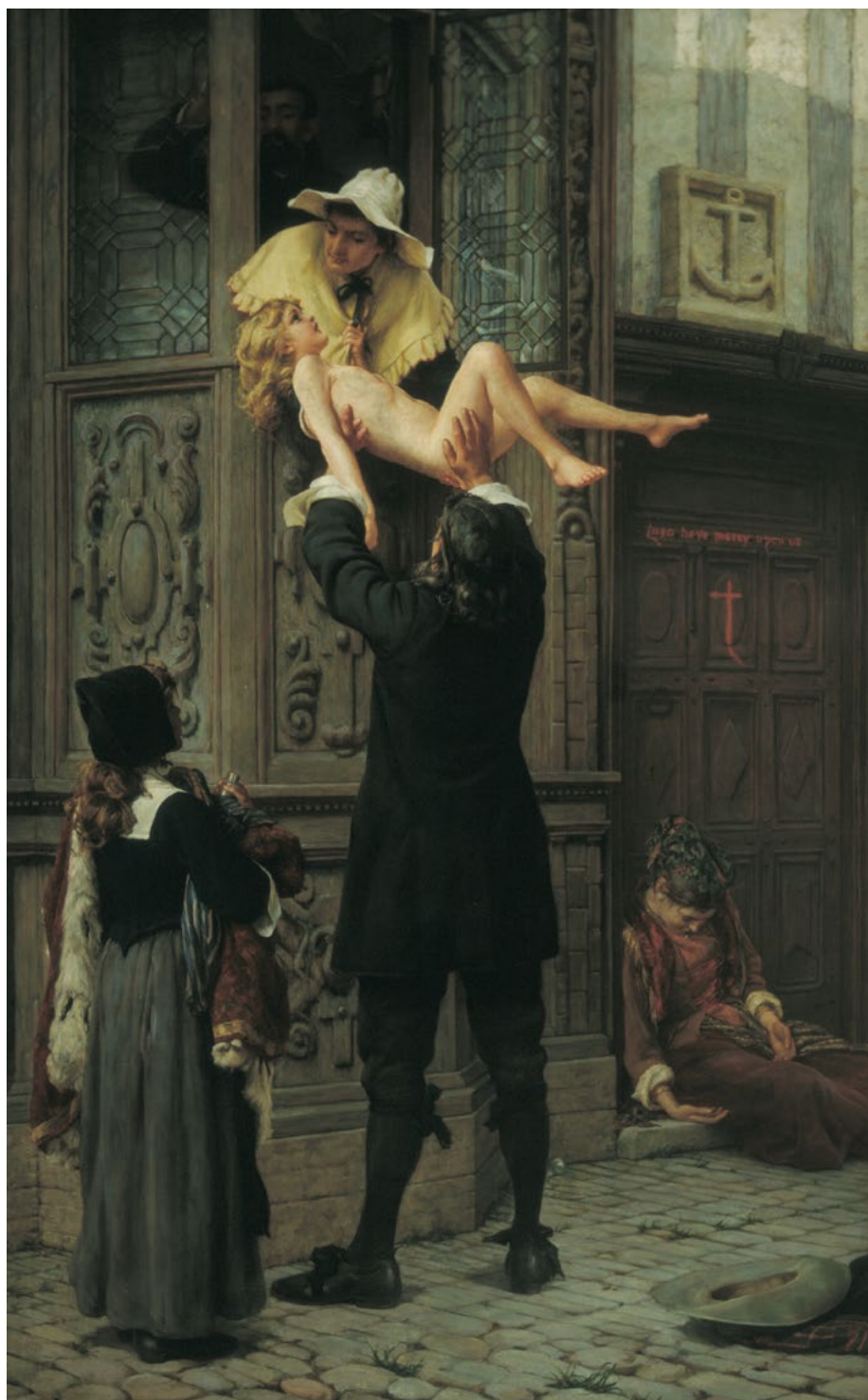

This picture was exhibited at the Royal Academy in 1898 (no. 636) with the following quotation in the catalogue:

“It was the child of a very able citizen of Gracious Street, a saddler, who had buried all the rest of his children of the plague, and himself and wife now being shut up in despair of escaping did desire only to save the life of this little child; and so prevailed to have it received stark naked into the arms of a friend.” – Pepys’ *Diary*.

Gracious Street, or Gracechurch Street, is in the City of London. The saddler’s little girl is handed down from an upstairs window into the receiving arms of the friend; his little companion stands by with fresh clothes. Within the first-floor room the father can be seen, steadying himself with one hand, forcing himself to watch the relinquishment of the girl. The mother is the more active figure, leaning out and passing the child on to the friend below. Pepys’ *Diary* for 3<sup>rd</sup> September 1665 goes on to recount the reception of the child at Greenwich where the friend lived; a complaint was made but it was decided that she would be allowed to remain. It is not known whether she remained healthy. A watercolour version of this picture is in the collection of the Arts Club, Dover Street London, donated by Romer Topham.

F. W. W. Topham worked both in oils and in watercolour. He studied informally under his father, the illustrator and genre painter, primarily watercolour painter, Francis William Topham (1808-1877). He studied formally at the Royal Academy Schools and under the academic painter Charles Gleyre in Paris. He became RI (Member of the Royal Institute of Painters in Water Colours) in 1879. He regularly exhibited at the Royal Academy from 1860 to 1904, favouring scenes from Shakespeare and Walter Scott, from classical and renaissance history and from the Bible.

His selection of a scene based on an incident in Pepys’ *Diary* reflects a resurgence of interest in Pepys following the first ever publication of a complete deciphering of the coded diaries in the 1890s. Pepys had always been popular but the 1890s saw a fresh appraisal of the directness of his account and the way that the diaries offered apparently unmediated access to his experience. With *Rescued From the Plague* Topham sought to channel the vigour and spirited nature of Pepys’ approach. His own work was regularly criticised for lacking ‘firmness of touch’ or ‘spirit and artistic purpose’.<sup>2</sup>

The picture shows that a young life can be protected and transferred from a place of death to a place of safety if a chain of participants acts together to make the transfer. The life of the young girl represents the family line which can be continued if she is rescued. The chain of people resembles the cable through which the electrical signal passes. The picture is also concerned with another kind of transmission, the transmission of disease. An abject

female figure begging on the doorstep reminds the viewer of the deadly alternative to the transmission of life.

CA

1. The Henry B. Wheatley edition appeared in 8 volumes plus 9<sup>th</sup> and 10<sup>th</sup> volumes containing index and addenda. The final portion of the diary was in vol. 8 published in 1896. Henry B. Wheatley, *The diary of Samuel Pepys, transcribed from the shorthand manuscript in the Pepysian library Magdalene college, Cambridge*, by The Rev. Mynors Bright, with Lord Braybrooke's notes; edited with additions by Henry B. Wheatley, 10 vols. (London: G. Bell & sons; Cambridge: Deighton Bell & co., 1893-1899).

2. *Athenaeum* (21 May 1892) p. 671; *Athenaeum* (2 June 1894), p. 716.

CATALOGUE ENTRY T6 | TRANSMISSION

WILLIAM LOGSDAIL (1859 – 1944)

# THE NINTH OF NOVEMBER, 1888, 1890

187 X 272 cm

GUILDHALL ART GALLERY, CITY OF LONDON CORPORATION



This painting of the annual Lord Mayor's Show depicts a central London location in a topographically accurate way, indicates a representative crowd of modern city types, gathered as onlookers, and elaborates a series of figures and vehicles representing the make-up of the parade. It sets up a striking contrast between the brilliant colours and shiny gold trimmings of the parade and the dull, largely monochrome appearance of crowd and street.

Logsdail exhibited at the RA from 1877. This picture was exhibited at the RA in 1890 (no. 1028) and was the only picture Logsdail showed in that exhibition. He had recently returned to London after a seven year sojourn in Venice.

The architecture is somewhat misted over in the cloudy atmosphere of a raw November day but the eight Corinthian capitals and the portico sculpture of the Royal Exchange are carefully depicted as the main backdrop for the procession.<sup>1</sup> The picture shows the view from the junction of Threadneedle Street and Cornhill. Looking past the Royal Exchange to the left, along Threadneedle Street, Logsdail shows the buildings of the Bank of England.

Footmen in elaborate livery are striding forward on the damp roadway. Horses, one ridden

by a liveried groom, follow; they are pulling the Lord Mayor's coach driven by the coachman. The annual procession, linked to the swearing in of the new Lord Mayor was of medieval origin. The gilded coach shown in the picture, used every year, was commissioned in 1757 and designed by the architect Sir Robert Taylor. It is now kept in the Museum of London. The new Lord Mayor for 1888-9, Sir James Whitehead is barely visible inside the coach. The bulky mace, a symbol of office projects from the window of the coach.

In his memoirs written 1925-27 Logsdail records his method of making studies of individual figures from actual participants (coachmen and footmen invited after the event to his Primrose Hill studio); people whom he locates in the crowd as colourful types (an Irish orange woman also brought to the studio from her pitch on the streets of London) and painter friends and other acquaintances who put on costumes or wore their own habitual hats and coats to model as policemen or onlookers.<sup>2</sup>

This was the shortest Lord Mayor's procession of the century; as an economy measure it had been scaled down. It occurred at a moment of high tension and outrage at police inefficiency on the day that a new murder by Jack the Ripper had been discovered.<sup>3</sup> The show of traditional pomp in modern times is shown as awkward. The leading footmen are slightly ridiculous in their extravagant outfits. Some figures on the pavements are impoverished. The police pin back the crowd but do not prevent acts of pilfering. Logsdail presents a ceremony that declares, as is traditional, power and authority (transmitting tradition). However he also shows the forces in the modern world that thwart transmission.

CA

1. It had rained overnight, was overcast by 11.00 am and maximum temperature was 46.3 degrees F. *Casebook: Jack the Ripper*, [www.casebook.org](http://www.casebook.org) (consulted 8th Aug 2016).

2. *William Logsdail, Reminiscences* (unpublished, written 1925-27), Coll. Logsdail family. Cited in *William Logsdail, 1859-1944, a distinguished painter*, exh. cat., Usher Gallery, Lincoln, (Lincoln: Usher Gallery, Lincolnshire County Council Recreational Services, 1994).

3. Mary Jane Kelly's murder was reported in the evening papers of 9th November 1888. <http://tinyurl.com/3ly6y5> (consulted 25th August 2016).

## CATALOGUE ENTRY T7 | TRANSMISSION

EDWARD JOHN POYNTER (1836 – 1919)

*ISRAEL IN EGYPT, 1867*

137 X 317 cm

GUILDHALL ART GALLERY, CITY OF LONDON CORPORATION



We see Egypt in the time of the Pharaohs. The picture displays careful study of archaeological finds but does not reconstruct one particular site, as *Blackwood's* put it 'he has violated the known topography of Egypt'.<sup>1</sup> Poynter brings together famous monuments assembled from different sites: for instance the temple and other buildings from Philae and the obelisk from Heliopolis. The pylon gateway from the Temple of Horus at Edfu was easily recognizable for Victorians from David Roberts's lithographic illustrations and the aquatints in the volume by Hector Horus.<sup>2</sup> The central red granite lion on the wagon was based on 18<sup>th</sup>-dynasty lions from the British Museum and the arrangement of double rows of lions adopted at the Egyptian Court in the Crystal Palace Sydenham. We can see the Great Pyramid of Giza in the background. The huge black granite figures are adapted from the granodiorite statue of Amenhotep III at the British Museum.<sup>3</sup> Poynter focuses on the play of physical forces and the march of time.

The picture was exhibited at the RA in 1867 (no. 434) with verses from the Bible taken from Exodus:

Now there arose up a new king over Egypt which knew not Joseph, and he set over Israel task-masters to afflict them with burdens. And the Egyptians made the children of Israel to serve with rigour. All their services wherein they made them serve was with rigour. Exodus, I: 8-14.

The Israelites are shown to be suffering in captivity. They are dragging a giant figure of the lioness Sekhmet, goddess of destruction, and are driven on with whips by Egyptian overseers. The feat of transferring this burden can be compared to the sending of a pulse down the cable.

The picture attracted a great deal of attention, some admiration for the evident labour expended in the learned details of the painting and some objections to the prominent gigantic lion, like a large painted plaster figure or pantomime lion made of cloth.<sup>4</sup>

In line with their standard practice of adapting fine art images for political cartoons, *Punch* reworked it in June 1867. Poynter was to be elected as ARA two years later in 1869 and as RA in 1876.<sup>5</sup> Chalk studies for figures pulling a rope are held at the Guildhall Art Gallery, London and at the Victoria and Albert Museum, London. Studies are also held in the Prints and Drawings collection at the British Museum. A watercolour of this composition 20 cm x 42 cm (signed and dated 1862) was sold at Sotheby's 19 October 1989 (no. 421).<sup>6</sup> The picture was reproduced as a wood engraving (with signature of engraver W. L. Thomas) in the *Illustrated London News*, 25 January 1868, pp. 84–85.

CA

1. *Blackwood's Edinburgh Magazine* (July 1867), p. 83.
2. David Roberts, *The Holy Land, Syria, Idumea, Arabia, Egypt and Nubia*, 3 volumes (London: F. G. Moon, 1842–49); Hector Horeau, *Panorama of Egypt and Nubia* (Paris: self-published, 1841).
3. These identifications were made by Patrick Conner in the Introduction to *The Inspiration of Egypt: its influence on British artists, travellers and designers, 1700–1900*, exh. cat. (Brighton: 1983). Statue of Amenhotep in British Museum catalogue, <http://tinyurl.com/hanuajs> (consulted 15 September 2016).
4. Detail admired, including the 'accurate ... mural decorations on the propylaeum' in *London Review* (8 June 1867), p. 649; 'painted plaster or canvas', *Art Journal* (June 1867), p. 139; 'buckram lion', *Blackwood's Edinburgh Magazine* (July 1867), p. 83.
5. Cartoon by Tenniel featuring Disraeli, *Punch* (15 June 1867), pp. 246–7; see Janice Carlisle, *Picturing Reform In Modern Britain* (Cambridge: Cambridge University Press, 2012), pp. 195–7.
6. Information from Object File, Guildhall art Gallery.

CATALOGUE ENTRY T8 | TRANSMISSION

# A THOMSON-STYLE REFLECTING ASTATIC GALVANOMETER MADE BY ELLIOTT BROTHERS [1860-1870]

KING'S COLLEGE LONDON ARCHIVES. K/PP107/11/1/21





In 1858 the first telegraph cable connection was made between Ireland and Newfoundland. It was a decided flop. Messages sent down the line were, for the most part, unintelligible. It took 16 hours to send the 98 words of Queen Victoria's message and the line failed after just three weeks. Engineers struggled not only with manufacturing problems but also with a mystery phenomenon which scrambled the messages they were attempting to send.<sup>1</sup>

Sir William Thomson, 1<sup>st</sup> Baron Kelvin, is today one of the best remembered scientists of the Victorian era, credited with the first and second laws of thermodynamics and the determination of Absolute Zero. Back in 1854, plain William Thomson was a rising star of physics working on Michael Faraday's calculations for a possible Atlantic telegraph cable. He noted that the cable would be subject to the effects of induction. When a voltage is passed down a very long, thin wire it builds up a charge, much like a battery. This charge then interferes with the message signals being sent. The bigger the charge the longer it takes to clear the line and the more slowly the letter signals can be sent. Thomson concluded that the core of the proposed cable needed to be of greater diameter than planned to overcome this. As this was in opposition to the ideas of the Atlantic cable company's own chief engineer, Wildman Whitehouse, he rapidly came to the attention of the company. In 1856 they brought Thomson on board as scientific advisor for the first Atlantic cable laying attempt.

Whitehouse and Thomson soon found themselves at loggerheads over the best way to solve the message scrambling problem. Whitehouse saw it as a problem of resistance, which could be overcome with higher voltages to force the message through. Thomson argued that they must minimise induction effects and use only very small voltages and very sensitive equipment. Thomson went away and designed the mirror galvanometer to test this.

The mirror galvanometer uses an electrical phenomenon to detect very slight electrical signals. When a current passes down a wire it sets up a magnetic field. Thomson's galvanometer detects this and registers a message signal in the wire. Inside the galvanometer is a small mirror suspended by a silk thread. A tiny magnet is attached to the back. A spot of light is reflected off the mirror onto a cardboard scale some distance away. When a signal enters the wire and a magnetic field is generated it pulls the magnet towards it. The mirror moves on the thread and moves the spot of light on the scale. If a positive current is sent it moves the mirror in one direction. If a negative current is sent it moves in the other. Positive and negative deflections can therefore be used as a 'dot' and 'dash' to send messages by Morse code.<sup>2</sup>

Thomson was proved right; low voltages detected with the mirror galvanometer proved to be the only way to send signals down the short-lived 1858 Atlantic cable. Queen Victoria's

congratulatory greeting to President Buchanan was sent via mirror galvanometer at ever decreasing speeds on the failing cable until the signal finally gave out forever. Thomson used the knowledge he had gained through the failure, to campaign for better cable design. Thanks in large part to Thomson, the successful cables of 1865 and 1866 had copper conductors of far higher purity with greater cross-sectional diameter and heavier, more perfect insulation. William Thomson was knighted in November 1866 for his contributions to the trans-Atlantic telegraph and went on to be made Baron Kelvin for his contribution to science.

CN

1. H. M. Field, *History of the Atlantic Telegraph to the Return of the Expedition of 1865* (printed only for private distribution, 1866).

2. M. Trainer, 'The Patents of William Thomson Lord Kelvin', *World Patent Information*, vol. 26, Elsevier Ltd, <http://tinyurl.com/hv4c2lk> (consulted 7 September 2016).

CATALOGUE ENTRY T9 | TRANSMISSION

# CONCERTINA AND TELEGRAPH TRANSMITTER

KING'S COLLEGE LONDON ARCHIVES. K/PP107/11/5/1 AND K/  
PP107/11/1/7



Charles Wheatstone leads an amazing double life. In one he is a pioneering hero of the telegraph, in the other he is the precocious inventor of musical instruments; the finest and most famous of these being the Wheatstone Concertina. These lives are not so separate as might be imagined and the cross-over between his work with sound, his work with electricity and his flair for engineering instruments and machines is very clear. In the exhibition two instruments illustrate this very clearly the concertina and the prototype telegraph transmitter.

Wheatstone began his professional career at the age of 14 when he was apprenticed to his uncle, a musical instrument maker. The rural Gloucestershire lad moved to London to begin work in Uncle Charles' workshop on the Strand. In the day he works in the shop and workshop. In the evenings he prowls the many bookshops, buying up volumes on natural philosophy. The young Charles builds a home-made physics laboratory, complete with his self-designed version of the Voltaic pile (an early battery) built from salt water, blotting paper and pennies.<sup>1</sup>

At the age of 20 in 1822 he comes to the attention of the public with the first of his several

acoustic ‘shows’ featuring the *Acoucryptophone* (translation: ‘hearing a hidden sound’) or *Enchanted Lyre*, an instrument which appeared to play ‘of itself’. The *Enchanted Lyre* – now housed in the Horniman Museum – was a small, ornately decorated harp, suspended by a steel rod which passed through the ceiling above. In the room above, the rod was connected to the soundboards of a piano forte and a dulcimer. The Lyre appeared to play through sound conduction and the sympathetic resonance of strings.<sup>2</sup>

The Enchanted Lyre was a research experiment as well as a publicity stunt for the family firm, and Wheatstone went on to publish his findings on frequency, resonance and the conducting of sound in Thomson’s *Annals of Philosophy* and the *Transactions of the Royal Society*. He soon became firm friends with fellow Royal Society member and physicist, Michael Faraday, who frequently delivered Wheatstone’s lectures for him at the Royal Society (Wheatstone being famously shy when it came to public speaking). He continued to publish throughout the 1820s until his work led to his appointment in 1834 as the first Professor of Natural Philosophy (what we now call physics) at King’s College, London.

Wheatstone, like Faraday, was concerned with the scientific principles behind phenomena. Where he was exceptional was that he then took that newly acquired knowledge and designed new instruments – be they musical or scientific – that exploited that knowledge. This was the case with the discovery of resonant frequencies that led to the invention of the concertina in the late 1820s and the experimental measuring of the speed of electricity that led to the design of the first practical system of telegraphy.

Wheatstone continued to have an interest in the family music business, and indeed a lifelong ‘admiration’ for music.<sup>3</sup> Not only did his work in physics produce such instruments as the concertina and harmonium but his skill in, and connections with, precision instrument manufacturing fed directly into the design of the first telegraph transmitters. The sales ledgers from Wheatstone’s commercial musical instrument workshop (digitised and available from the Horniman Museum) show that they were building experimental electrical apparatus for use at King’s from the 1850s.<sup>4</sup>

The visual similarity between the concertina and prototype telegraph key is striking. But the polished mahogany, turned ivory buttons, delicate springs-loaded keys, and finely milled brass fittings underline much deeper connections between Wheatstone’s passions: understanding and invention, music and physics, craftsmanship and engineering.

1. B. Bowers, *Sir Charles Wheatstone FRS, 1802-1875*, IEE History of Technology Series, vol. 29 (London: The Science Museum, 2001).
2. N. Wayne, 'The Invention and evolution of the English Concertina', *Journal of the Galpin Society*, Vol. LXI (2009).
3. Wayne, 'English Concertina' (2009).
4. *Wheatstone & Co. Concertina Ledgers, 1839-1891*, <http://www.horniman.info/> (consulted 7 September 2016).

CATALOGUE ENTRY T10 | TRANSMISSION

# WHEATSTONE AUTOMATIC 'JACQUARD' TELEGRAPH TRANSMITTER [1858-1867]

KING'S COLLEGE LONDON ARCHIVES. K/PP107/11/1/8



Charles Wheatstone launched the Automatic or Jacquard telegraph in 1858 as part of his Universal Telegraph Company system. Where the ABC, or Universal Telegraph was designed to bring the telegraph into every home, the Automatic was designed to massively increase signalling speeds. Wheatstone had been experimenting with an automatic system for some time because, on land lines at least, the signalling speeds achieved by even the best telegraph operators were a long way below the maximum capacity of the lines. There was unexploited potential to increase traffic with the right machine.<sup>1</sup>

The Automatic system consisted of one (or several) Perforators, a Transmitter and a Receiver. Perforators were manually operated hole punches into which the operators punched holes, either to the left of the strip or the right, to stand for the dots or dashes of the message. The speed of the passage of the tape through the machine was controlled by the punching action. The tapes were then taken and threaded into the Automatic Transmitter. As the strip passed through the machine it passed underneath two delicate metal wires, one on the left for the dots, one on the right for the dashes. The metal wires were sprung so each time they passed over a hole in the tape they made contact with the

metal surface beneath. Wheatstone used this contact to complete an electrical circuit and send either a dot or a dash down the line. At the other end were two pens, one operated by the dash signal and the other by the dot, which inked another continuous tape.

The Transmitter and Receiver could be run at up to 120 words per minute on landlines. Several telegraph clerks could be employed simultaneously perforating the message strips to be fed into one Automatic Transmitter, making the system five times faster than anything known at the time. The Automatic system was put to use in the very busiest of long-distance circuits, such as that between London and Manchester. It has been claimed that ‘after the initial invention of the telegraph, the most important step in its development ... was the introduction of the Wheatstone automatic system’.<sup>2</sup>

Wheatstone had been working on the design of the Automatic Telegraph since around 1850. The machine he launches with fanfare in 1858 is the product of several ideas and influences. As the name suggests it was particularly inspired by the Jacquard Loom, invented in 1801 by Joseph Marie Jacquard as a way of automating the weaving of complex patterns. The loom was the first programmable machine; it automatically pulled a chain of punch-cards through a reader to set each individual line of the weave. Alexander Bain’s Mechanical Telegraph, though mechanically very different, is the acknowledged forerunner of the idea of every automatic telegraph. There is some debate over whether this complex device is a machine or a contraption.<sup>3</sup> Patented in 1841, Bain’s machine used pulses of electricity to start and stop a clockwork type-wheel.

There is, however a third possible (and unexplored) source of inspiration in Charles Babbage’s second difference engine; the Analytic Engine. The engine, like Jacquard’s loom, used chains of cards as a way to create continuous loops of operations but it was also able to punch its own cards as a way of feeding back results. Babbage detailed this two-way operation in the mid-1830s and continued to work on the design for the machine into the late 1850s.<sup>4</sup> As Babbage and Wheatstone were contemporaries, both members of the Royal Society, and - through their respective lectures at the Royal Institution - keenly aware of each other’s work, it seems likely that this exchange of ideas influenced both men’s work.

CN

1. S. Roberts, *Distant Writing* (2012), <http://tinyurl.com/grf3p2j> (consulted 22/08/2016).

2. B. Bowers, *Sir Charles Wheatstone FRS, 1802-1875*, IEE History of Technology Series, Vol. 29 (London: The Science Museum, 2001), p.183.

3. S. Roberts, *Distant Writing* (2012)

4. J. Essinger, *Jacquard’s Web: How a hand-loom led to the birth of the information age* (Oxford: Oxford University Press, 2004).

# CODING





CODING

# ANNE CHAPMAN

CODED ENCOUNTERS: TISSOT'S *THE LAST EVENING*

Fig. 1, James Tissot, *The Last Evening*, 1873, Guildhall Art Gallery, City of London Corporation.

*The Last Evening* depicts a tense and ambiguous shipboard encounter, a coded encounter situated within a patterned, repetitive and also coded environment. Five people face away from the glow of an unseen setting sun reflected on clustered and partially obscured clouds; they pay no attention to the beauty of the evening, instead seeming to concentrate elsewhere. The painting's title suggests that their intense scrutiny relates to the significance of this evening being the last. James Tissot groups together his claustrophobic huddles of protagonists on a deck compressed by awkward perspective. They seem shut in together as repetitions of rigging obliterate the horizon, that orienting marker of space. So confined, they make attempts at reading, at deciphering the meaning of each other's expressions and bearing. In the foreground the ship's mate gazes thoughtfully at a young woman.<sup>1</sup> She reclines under a bright red travelling rug; its colour draws attention to itself and thus, as travelling is passing not permanent, to the temporary nature of the situation. Tissot presents the couple's relationship ambiguously: the mate's attempt to wrap an arm around the woman seems thwarted by the chair in which she sits, yet his firm hand steadies this rocker. She does not return his gaze. Two older gentlemen sit a little behind and one, the captain, almost looks at the couple. The other, wearing a top hat, is older. He glowers intently at his companion, his face almost touching the captain and his eyes seeming to rest on the other man's cheek or ear. Finally, close behind yet entirely ignored, a young girl looks on as she watches the face of the elderly man. Tissot brings his intimate groups close

enough to overhear each other. They seem to be on the verge of a whisper, secret messages about to be shared, yet in such a confined space there is no privacy for spoken secrets. Mouths shut, no one utters a sound. If these people have messages to communicate, they do so corporeally rather than verbally. Their scrutinising looks suggest that they attempt to read meaning encoded in each other's bodies. Yet not one look is returned; there is no reciprocity.

Tissot first exhibited *The Last Evening* at the Royal Academy in 1873 alongside *The Captain's Daughter* and *Too Early*. These two address similar themes to *The Last Evening*; the former is another depiction of scrutiny and of the difficulty of meeting someone else's gaze, and the latter, away from the water this time, depicts a ballroom where unknown codes and social illiteracy compound to make an awkward spectacle. At the time of the exhibition, the *Contemporary Review* stated that 'M. Tissot requires nothing from the spectator except a solution of the problems put before him' and proceeds to make clear that those problems are ones of reading people and 'leaving too much to the imagination'.<sup>2</sup> *The Last Evening* demands as much scrutiny from its audience as its cast of characters give to each other. It invites us to look for clues, to read and re-read applying our own knowledge of the complex corporeal codes through which relationships play out. More recent criticism describes Tissot's works as 'visual invitations to narrative'.<sup>3</sup> Such an invitation, one that presents itself as a problem to be solved, affords ambiguity; little wonder then that Russell Ash's response to *The Last Evening* finds 'storylines so tenuous or ambiguous as to leave the viewer questioning what human drama is actually being revealed'.<sup>4</sup> These are complicated instances of communication both between the painting's characters and between artist and audience.

At the time when Tissot produced *The Last Evening*, telegraphic communication was pervasive, one of many media shaping the nineteenth-century cultural imagination; as a system of communication it depended on code. Telegraphic codes allowed clear transmission reliant on a shared key that all operatives could send and read. They could take someone else's message and transform it with a communication system that its original writer might not comprehend, into electrical patterns of switching on and off. Such an act of encoding makes messages at once transparent and opaque, structured by codes to which only specialists have the key; a telegrapher creates a pattern which communicates only to other telegraphers. But there could be more than one code at play; only the message's originator and recipient may understand the meaning of the words encoded and decoded for them by telegraphers.

Thus a telegraphic culture communicates by composing meaning using the rules of different codes and keys, the success of which depends upon technical mastery. In *The Last Evening* Tissot draws our attention to skilful composition. Both the edges of the

distinctly patterned travelling rug and of the checked dress worn by the young woman reveal the structural components: Tissot picks out the individual threads, black, white, red, and yellow, emerging from the fabric into which they have been woven, fabric constructed through a repetitive, coded process creating patterns. Tissot's use of such uniformly patterned fabrics encourages his audience to think about the expertise involved in their creation, a transformative act in which the skilful weaver (man or machine) joins individual strands together through the encoded action of following a pattern. The open weaving of the chairs on which the couple sit emphasise reliance on skilful fabrication.

Whilst Tissot presents these patterns distinctly, at the same time he presents the equally repetitive structural patterns of the ships' rigging as unreadable. The overlaying of many instances of these ordered ropes obscures their form and viewers find it impossible to distinguish one ship from another. Tissot not only shows us the ropes formed into the structures of rigging, he also places a carelessly wound, potentially tangled rope hanging centrally to the painting and another lying discarded on the deck, escaping out of the right-hand side of the picture. They intimate both a job performed and potential future use; the repetitive process of encoded construction is ongoing here. In these many instances of systems of patterned transformation, both the parts (threads and ropes) and their sum (cloth and rigging), contextualise Tissot's protagonists in a world in which codes are visible structures that repeat profusely. Indeed the repetitions seem to go on endlessly, to the point that decoding seems superfluous.

Even when we can see all the parts and the system, decoding requires something more. Turning our attention from the structure of the setting to the social moment depicted by Tissot, the ambiguity of the narrative he has carefully composed shows that legibility depends not only on clarity of media. Without a key to rely on we must provide an imaginative reading. In receiving Tissot's message, we see each of his characters clearly, the direction of their gazes and the expressions on their faces, their proximity to each other and the positions of their hands. And yet the nature of the relationships between these five slips away the more attentively we look. Although he confines us to the deck with the characters, Tissot keeps us just far enough away for *The Last Evening* to invite us to read everyone all at once. Thus he urges the viewer to consider the relation of one thing to the next, rather than decode a single expression closely as the personally-focused participants do. In trying to identify connections, the viewer creates his or her own narrative. Tissot shows us that a situation can yield private and public messages simultaneously.

Despite its indecipherability, Tissot does present proximity as attractive. In the centre of the foreground the captain's limp hand holds his disregarded newspaper, a blur of illegible print without a single clear letter, contrasting with the precise rendering of patterned fabric and its fringes. The news (reporting from a distance) appears unreadable and

uninteresting; a close reading of people nearby holds attraction instead. Distant news takes time: newspapers communicate comparatively slowly through witnessing, reporting, editing, printing, selling and buying, but *The Last Evening* turns its characters' gaze on the immediate moment. The painting's title insists on the significance of the moment. The temporality of messages concerns Tissot here: the connection between reading, meaning and a particular moment in time. The title affects the questions that we ask about the relationships before us. The viewer wonders what consumes these character's thoughts and what the finality of this moment might mean to them. Tissot makes evident that in an always encoded environment, even when we can discern the structure of the code, meaning derives from the questions we ask of the message.

Such interrogative proximity makes the sending of messages equally problematic in *The Last Evening*. Each character directs attention towards someone else, yet they display no awareness that they transmit a message to another. Each protagonist fails to display any conscious effort in encoding their own body, as none of them notice that they themselves are being read. These messages demand decoding yet their encoding lacks deliberation. Tissot shows us messages being read where none are intentionally sent. Where one sends a message unconsciously, transmitting that message only because it is looked for, then the message is in fact defined by the recipient. These characters do not choose a code with which to communicate, yet they are communicating.

In a straightforward metaphor telegraphy can be used as an image of romantic connection, a connection based on the sharing of code. *The Last Evening* approaches code in a different way. Tissot emphasises a lack of connection not only with unmet gazes, but equally with the placement of hands. A poem and accompanying illustration from *Belgravia: a London magazine*, only two years after the exhibition of *The Last Evening*, reveal the kind of messaging where comprehension arises directly out of connection. Here reciprocity determines meaning. In 'Love's Telegraphy' by H Savile Clarke a 'happy maiden' plays a game of blind man's bluff and tries to guess the identity of those of whom she catches hold. 'At last one hand is in her own---/ Ah, beating heart, be still! One name at last is surely known/ By love's electric thrill [...] the tender thoughts transmitted then'.<sup>5</sup> Savile Clarke portrays reciprocated touch communicating a clear romantic message between the couple. Tissot's protagonists, however, keep their hands to themselves. Where a hand is clasped, it is in its owner's other. Proximity invites inspection but Tissot shows readers who fail to connect with their texts.

And yet, not one of these faces even hints at confusion, or suggests trouble in reading. Isolated from each other, they nonetheless seem to find themselves confronted by that which makes sense. In this way Tissot distances his audience from his painting; its ambiguity maintains our confusion while his characters reveal none of the bewilderment

which comes with the indecipherable. In *The Last Evening* Tissot suggests that amidst a skilfully encoded and decoded culture there is a consuming satisfaction in indulging an imaginative and deeply personal reading to which only the individual reader has the key.

1. The two uniformed men here are the same as in *The Captain and His Mate* (1873, Private Collection) and so we can take these titles to be their roles.
2. John Forbes White, 'The Royal Academy Exhibition of 1873', *Contemporary Review*, vol. 22 (1873), p. 288.
3. Carole G. Silver quoted in Katharine Lochnan, 'Introduction', in *Seductive Surfaces: The Art of Tissot*, ed. by Lochnan (New Haven: Yale University Press, 1999), p. xiv.
4. Russell Ash, *James Tissot* (London: Pavilion, 1995), plate 15.
5. H. Savile Clarke, 'Love's Telegraphy', *Belgravia: a London magazine*, vol. 5 (1875) p. 534.

CATALOGUE ENTRY C1 | CODING

SIR JOHN GILBERT (1817 – 1897)

# *EGO ET REX MEUS: KING HENRY VIII AND CARDINAL WOLSEY, 1888*

160 X 104 cm

GUILDHALL ART GALLERY, CITY OF LONDON CORPORATION



Telegraphic communication was made secret by the use of codes, a secrecy essential to its commercial and political use. In *Ego et Rex Meus*, Sir John Gilbert presents the machinations of political secrecy as an exercise of power: King Henry VIII and Cardinal

Wolsey are seen locked together in private conversation but the title translates as ‘I and my King’, suggesting a dominance of the Cardinal over a monarch of whom he has control. The incident depicts Act I Scene II of Shakespeare’s *Henry VIII*. The play commences with a Prologue that emphasises truth juxtaposed with an opening scene that introduces Wolsey as a suspicious character: ‘this cunning cardinal’. In *Reproductions of the Pictures by Sir John Gilbert presented to the Corporation of the City of London* the description of the painting accompanying its collotype copy quotes Act I Scene II’s opening lines. The King says to Wolsey: ‘My life itself and the best heart of it,/ Thanks you for this great care: I stood i’ the level/ Of a full charged confederacy, and give thanks/ to you that chok’d it’.<sup>1</sup> Henry is thanking his Cardinal for protecting him; his gratitude for ‘great care’ suggests he has trust in Wolsey, but both the play’s audience and the painting’s viewers are encouraged to wonder if this trust is misplaced. Whilst the King and Wolsey huddle together secretively, we find tension and unease here. Gilbert portrays Wolsey as sly and the King as being unable to read his Cardinal’s face: he has his eyes shut. The Cardinal also prevents Henry from reading the rolled up papers tightly gripped in his hand, their words hidden from view; Wolsey holds them across his body away from the King. In the play the scene proceeds to reveal that Wolsey has set taxes without the King’s knowledge and he demands that his secretary tell a lie about the origin of those taxes’ repeal. Gilbert reflects this as he portrays the Cardinal pulling his scarlet robe around him. This gesture suggests the creation of a boundary between himself and the King, a gesture that presents Wolsey as the secretive and self-protecting character of Shakespeare’s scene.

*Ego et Rex Meus* is just one of Gilbert’s many paintings and illustrations of Shakespearean scenes. His contributions illustrating *Henry VIII* for Howard Staunton’s *The Works of Shakespeare* (also titled *Sir John Gilbert’s Shakespeare*) total sixteen and include a version of the scene painted here. This picture was exhibited in the RA in 1889 (no. 293), and was his only picture in this exhibition. Gilbert was elected to be ARA in 1872, the same year in which he received his knighthood, and RA in 1876. He was also president of the Royal Watercolour Society for over twenty-five years.

The painting is one of a large collection of Gilbert’s works held by the Guildhall Art Gallery, a collection which includes another depiction of the Cardinal, the watercolour *Cardinal Wolsey, Chancellor of England, on his Progress to Westminster Hall* (1887). Having already resolved to discontinue selling his work in 1885, Gilbert distributed his paintings amongst a number of galleries in 1893 including the Guildhall.<sup>2</sup> Their collection grew due to a bequest from Gilbert’s brother in 1903. In the year of his initial donation, the Corporation of the City of London presented Gilbert with the Freedom of the City, the first time an artist received this honour.



1. A. G. Temple, *Reproductions of the Pictures by Sir John Gilbert presented to the Corporation of the City of London* (London: Blades, East & Blades, 1893), p. 10.

2. For a chronology of Gilbert's life and work, see: Spike Bucklow and Sally Woodcock (eds.), *Sir John Gilbert: Art And Imagination in the Victorian Age* (Farnham: Lund Humphries in association with Guildhall Art Gallery, City of London, 2011), pp. 13-17.

CATALOGUE ENTRY C2 | CODING

JAMES TISSOT (1836 - 1902)

# THE LAST EVENING, 1873

72 X 103 cm

GUILDHALL ART GALLERY, CITY OF LONDON CORPORATION



Having been born and having grown up in the French port of Nantes, James Tissot, in later years, gave many of his images of courtship a marine setting. *The Last Evening* suggests a shipboard romance that may be coming to an end, its protagonists under scrutiny. The ring on the young officer's finger signals that he is married. The young lady, who has no ring on hers, is apparently not his wife. Tissot sets up a series of glances that make it impossible fully to decode the 'story' here.

Although he would not move to London until the early 1870s, Tissot first exhibited at the Royal Academy in 1864. This picture was exhibited there in 1873 (no. 121). At the same exhibition, he showed two other pictures: *The Captain's daughter* (no. 108) and *Too early* (no. 914).<sup>1</sup> At the time of the exhibition, the *Contemporary Review* stated that 'M. Tissot requires nothing from the spectator except a solution of the problems put before him' and proceeds to make clear that those problems are ones of reading people and 'leaving too much to the imagination'.<sup>2</sup> *The Last Evening* demands as much scrutiny from its audience as its cast of characters give to each other.

In *The Last Evening* Tissot groups together claustrophobic huddles of protagonists on a deck compressed by awkward perspective. He shuts them in together and repetitions

of rigging obliterate the horizon, that orienting marker of space. So confined, they make attempts at reading, at deciphering the meaning of each other's expressions and bearing. In the foreground the ship's mate gazes thoughtfully at the young woman. She reclines under a bright red travelling rug, its colour drawing attention to itself and thus, as travelling is passing not permanent, to the temporary nature of the situation. Tissot presents the couple's relationship ambiguously: the mate's attempt to wrap an arm around the woman seems thwarted by the chair in which she sits, yet his firm hand steadies this rocker. She does not return his gaze. Two older gentlemen sit a little behind and one, the captain, almost looks at the couple. The top-hatted elder of the men glowers intently at his companion, his face almost touching the captain and his eyes seeming to rest on the other man's cheek or ear. Finally, close behind yet entirely ignored, a young girl looks on as she watches the face of the elderly gentleman. Tissot brings his intimate groups close enough to overhear each other. They seem to be on the verge of a whisper, as if there are secret messages about to be shared, yet in such a confined space there is no privacy for spoken secrets. Mouths shut, no one utters a sound. If these people have messages to communicate, they do so corporeally rather than verbally. Their scrutinising looks suggest that they attempt to read meaning encoded in each other's bodies just as we attempt to decode the narrative of the relationships Tissot only hints at in his painting.

AC

1. Although it appears that *The Last Evening* and *The Captain's Daughter* were hung with their labels mixed up, the RA catalogue assigns the numbers as given here.

2. John Forbes White, 'The Royal Academy Exhibition of 1873', *Contemporary Review*, vol. 22 (1873), p. 288.

CATALOGUE ENTRY C3 | CODING

SOLOMON JOSEPH SOLOMON (1860 – 1927)

# A CONVERSATION PIECE, 1884

97.5 X 122.5 CM

THE ROYAL BOROUGH OF KENSINGTON AND CHELSEA, LEIGHTON  
HOUSE MUSEUM

In this painting of a late-Victorian, upper-middle class drawing room, semi-hidden figures and a fractured web of glances create an enigmatic mood. *A Conversation Piece* explores attention and distraction and the possibility of secret messages failing to be received.

Solomon first exhibited at the Royal Academy in 1881 and his subsequent frequency in showing there led to the space reserved for his paintings being known as ‘Solomon’s corner’.<sup>1</sup> However *A Conversation Piece* was not exhibited in the 1884 RA exhibition, although Solomon showed two other pictures there in that year: *Ruth* (no. 908) and *Portrait of a gentleman* (no. 926). Solomon was elected to be ARA in 1896 and RA in 1906, the second Jewish Royal Academician (the first being Solomon Alexander Hart (1806-1881)).

Although overlapping, the figures in *A Conversation Piece* seem disconnected, each isolated and frozen. In spite of the musical accompaniment provided by the girl in white seated at her instrument, Solomon presents a quiet, still scene. The painting’s title refers to a type of group portraiture, often presenting its participants quite informally, although not necessarily in conversation. But in addition, Solomon’s use of this title draws the viewer’s

attention to the fact that here none of the participants attempt conversational interaction. *A Conversation Piece* seems instead entirely concerned with display. Pattern adorns every surface, and ornamental items, from lamps and figures to peacock feathers and framed pictures, stand on every available space. Solomon not only makes much of this array of items gleam with reflected light, he also draws our attention to illumination, depicting a maid in the background lighting a lamp. She supplies visibility. This visual display is not straightforward however. Solomon complicates the spectacle as he contrasts attention with deception with his inclusion of the peacock feathers and tiger skin rug: the former, understood to be a conspicuous device to attract a mate, is placed away from the glare of the lamps in a dark corner, whilst the latter, a set of markings which offered camouflage in the shadows, is foregrounded and brilliantly lit. With this inversion Solomon emphasises disguise and deception. His interest in disguise and visibility were later shown when he worked on camouflage during the First World War, publishing the book *Strategic Camouflage* in 1920.<sup>2</sup>

The smart young man in the foreground of the picture fails to reciprocate his companion's admiring gaze, instead concentrating on the *carte de visite* in his hand. She wears a lilac dress with row upon row of flounces and is as showy as the decoration of the room. Amongst such abundant display however, the girl fails to stand out; not only is she ignored by the object of her admiration, but also none of the others take the opportunity to oversee and monitor the potential lovers. Solomon presents such excess of ostentation as a hindrance, failing to generate the usual benefits of display. It has a deadening effect and impedes action. Indeed, only the athletic sculptures that decorate the room present action, but even there Solomon shows action held still, permanently stopped motion. Perhaps the most striking feature of the painting is the strange owl lamp glowing bright red from the background. Its brilliant eyes stare, stretched fully open, yet they direct their gaze at nothing. They suggest a state of bedazzlement appropriate to the excessive display. In this picture Solomon depicts a state of profusion where it is possible to hide secrets in plain sight.

AC

1. Jenny Perry, *Solomon J Solomon RA* (London: Ben Uri Art Gallery, 1990), p. 5.

2. Solomon J. Solomon, *Strategic Camouflage* (London: John Murray, 1920).

CATALOGUE ENTRY C4 | CODING

GEORGE FREDERIC WATTS (1817 – 1904)

# ARIADNE ON NAXOS, 1875

75 X 94 cm

GUILDHALL ART GALLERY, CITY OF LONDON CORPORATION



Ariadne stares out to sea in grief caused by the desertion of Theseus, her lover, who left her sleeping on the island of Naxos' shore. In her hand she holds a ball of red thread symbolising her continued connection to Theseus, in spite of his betrayal (she had provided the ball of thread and sword that assisted his escape from the Minotaur's labyrinth). Her servant points in the other direction, signaling that Dionysus is coming to claim Ariadne as his bride. Watts depicts an opposition here between the languid longing of Ariadne with her limbs loose, her hair fallen and her clothing disheveled, and the resolute insistence in her more ordered servant's firm indication. The picture is therefore about the switch point between two alternatives: Theseus and Dionysus; lassitude and energy; briny waste and lush woodland; romance and sex. Many telegraph codes depended on binary switching, a switching between right and left or between dots and dashes with the breaking or completion of an electric circuit.

Other examples of Watts' interest in switching include *Choosing* (1864) his portrait of the then seventeen year old Ellen Terry, the Victorian actress who would briefly be his wife. In this portrait, now at the National Portrait Gallery, we see Terry symbolically choosing

between gorgeous, flamboyant, but barely scented camellias and delicate, simple, but highly perfumed violets.

Watts was elected to be ARA in January 1867 and RA in December that same year. *Ariadne on Naxos* was not exhibited at the Royal Academy, although in 1875 he showed five pictures there, including *Blanche* (no. 266) and *The late Marquis of Lothian* (no. 420). Watts studied the Elgin Marbles (removed from the Parthenon in Athens and on display in the British Museum) from an early age and their influence can be seen here as the painting imaginatively completes fragmentary figures from the pedimental sculptures.<sup>1</sup> His representation of classical subject matter was extensive; for example he also painted a number of versions of *Orpheus and Eurydice* and *Endymion*. He often tackled classical subjects in the sculptural works that he started to make in the latter part of his professional life. Watts considered Ariadne throughout his career. In 1863 he first exhibited a painting of the abandoned goddess at the Royal Academy and he produced later versions and re-workings up to the 1890s. This 1875 representation of the scene is considered Watt's most complete version and seems to have been influenced by *Titian's Bacchus and Ariadne* (1520-23) which Watts had copied in London's National Gallery;<sup>2</sup> there are echoes of Titian's landscape and composition here, although, unlike Titian, Watts does not include Theseus and Dionysus. Their absence suggests that the nature of the alternatives matter little here; the moment of the switch itself holds significance.

AC

1. Stephanie Brown, 'Watts and Sculpture' in G. F. Watts *Victorian Visionary: Highlights from the Watts Gallery Collection*, ed. by Mark Bills and Barbara Bryant (New Haven: Yale University Press in association with Watts Gallery, Compton, 2008), p. 59.

2. Barbara Bryant, quoted in Veronica Franklin Gould, Hilary Underwood and Richard Jefferies, 'The Catalogue' in *The Vision of G. F. Watts OM RA (1817-1904)*, ed. by Gould (Surrey: Watts Gallery, 2004), p. 52.

CATALOGUE ENTRY C5 | CODING

# ABC TELEGRAPH TRANSMITTER

KING'S COLLEGE LONDON ARCHIVES. K/PP107/11/1/5





In 1840 sending a telegram was a time consuming business. First you had to visit your local telegraph office, fill out the message form, pay the clerk, wait for the nosy clerk to send the message about your private business and then wait again while a second (probably equally nosy) clerk copied it out at the other end. At this point a telegraph boy walked it the last mile or so to its final destination. You would then wait, all over again, for the process to be repeated in reverse and the reply to arrive. Telegraph pioneer, Charles Wheatstone, had a rather different vision for telegraphy.

Wheatstone dreamed of a universal system where everybody, every home, office, bank, factory and workshop would have access to instant 'electric mail'.<sup>1</sup> The bureaucracy of telegraph clerks, engineers and offices could be wiped out in a stroke and messages sent promptly, privately and directly from one personal machine to another. He designed and built the ABC transmitter to make this dream a reality. It was to be the simplest of machines and was intended to be operated safely by anyone, regardless of age, sex or training. If you could spell the word then you could telegraph it with a simple turn of the handle.

The system had three working parts: the generator, the communicator and the indicator. The generator was built to eliminate the need for batteries. The Daniell cell battery - despite being a great advance - was still heavy, required knowledge to put together, and - most important from a public safety standpoint - filled with sulphuric acid. To power the ABC telegraph Wheatstone designed an electro-magneto generator. It exploited Faraday's recent (1831) discovery that if you set an iron rod wrapped in copper wire (an armature) spinning inside some magnets, electricity is produced. Wheatstone attached the copper armature to a handle on the outside of the case. When the handle was turned it created a small pulse of electricity that could be used to send the signal.

The communicator was a toothed disc with all the letters of the alphabet, numbers and common punctuation marks marked upon the face. The sender pressed the button for the letter he or she wanted to send and then turned the handle. Each pulse from the handle moved the disc on one letter. When the disc got round to the required letter it automatically broke the circuit and set the machine back to its zero state. The sender then pressed the button for the next letter and again began turning the handle. At the indicator, or receiving end, was a second dial marked with letters and numbers. Each time an electrical pulse was received down the line the dial moved on one letter. The person at the receiving end wrote down the letter and the dial was set back to zero. With practice up to 15 words per minute could be sent (compare with our average mobile-phone texting speed of 35 words per minute!).<sup>2</sup>

Wheatstone improved on his *ABC Telegraph* and in 1858 patented the *Universal Telegraph Receiver*. In 1860 he founded *The Universal Private Telegraph Company* and began building his visionary system. By 1868 20% of all telegraph lines belonged to private companies and individuals, all of which were swept away after the nationalisation of the telegraph companies in 1870. The GPO changed the system's name back to the *ABC Telegraph* and distributed the easy-to-use devices to the new – and largely untrained – telegraph staff in local post offices. The world had to wait more than a hundred years for Wheatstone's dream of 'electric-mail' to finally become a reality.

CN

1. S. Roberts, *Distant Writing* (2012), <http://distantwriting.co.uk/privatetelegraphy.html> (consulted 4 September 2016).

2. Roberts, *Distant Writing* (2012).

CATALOGUE ENTRY C6 | CODING

# CODE BOOKS

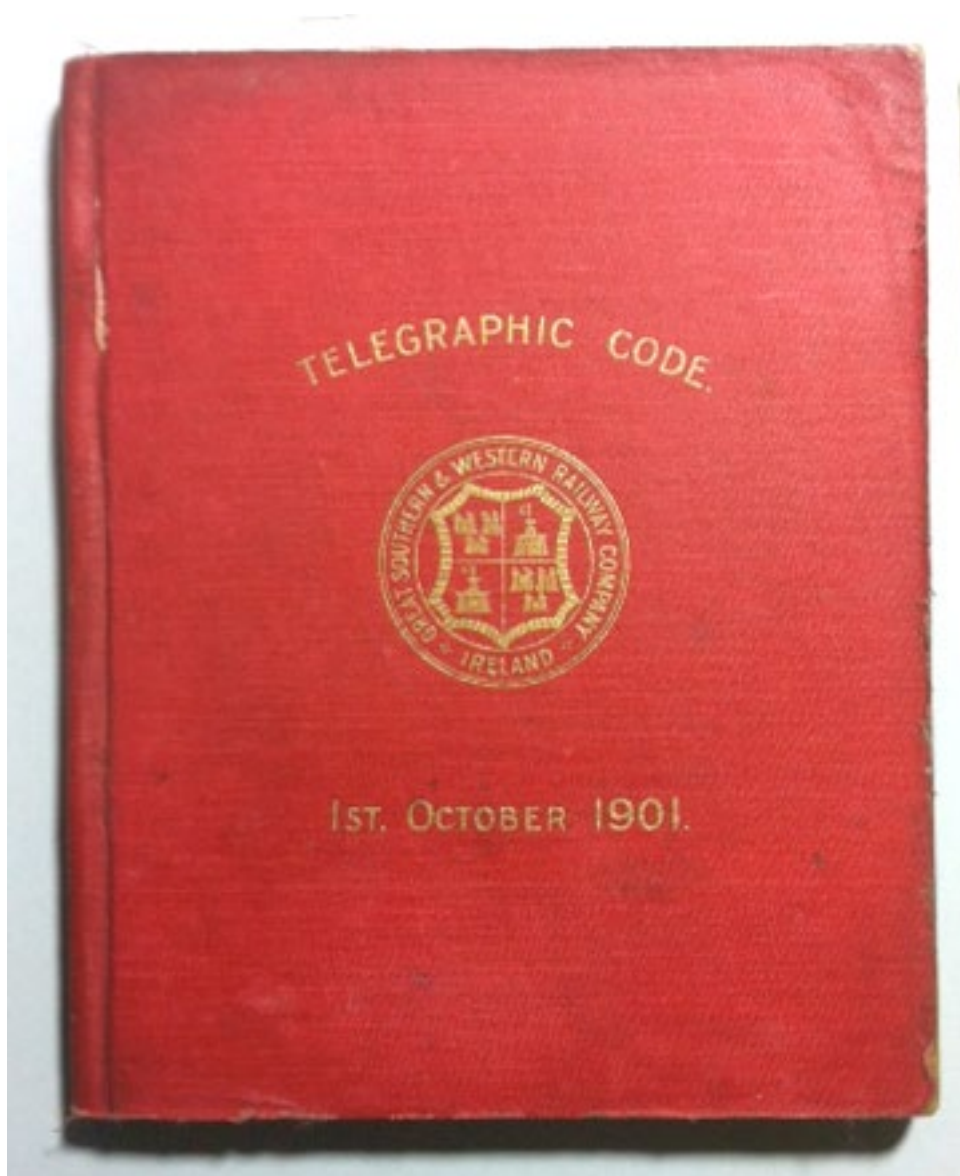

Telegrams may have been astonishingly fast but they were anything but private. In the UK, large businesses and other organisations could invest in one of Wheatstone's Universal Telegraph Company's private systems to connect their personal workshops, factories and offices. Longer distance messages - and certainly all international traffic - had to pass under the eyes of multiple telegraph clerks and telegram delivery boys. For many organisations this message transparency was totally unacceptable.

The police, for example, deal in information which needed to be widely shared but was too sensitive to be relayed on public lines. Williamson's Police Telegraph Code (1885) was produced to keep police messages private and also allow them to be usefully shortened.<sup>1</sup> It is divided into thematic headings, such as 'suspect appearance' or 'crime wanted for'. A single code word can stand for a whole phrase, for example 'FELONY FENCEFUL FETLOCK' decodes as 'the suspect has two teeth out in front, a slightly turned up nose and is a smooth talker'. For speed, police code books are often laid out in the order that a police report is written.

Individual businesses and industries developed their own code books. Not only did they preserve company secrecy but also allowed messages to be shorter and cheaper by having one code word stand for whole sentences. It helped with the accurate sending of jargon and industry related words and also reduced the monotony of sending frequently repeated information.

The same issue of privacy also applied to all personal telegraph traffic, and code books were produced for the use of private individuals. *Unicode: the Universal Telegraphic Phrase Book* (1894) was a long-running and often reprinted code book of cipher words for 'Commercial, Domestic and Familiar Phrases in Ordinary Use'. Used all over the world, Unicode covered everyday occurrences such as births, deaths, lunch engagements, marriages, racing, hotels and theatre engagements.<sup>2</sup>

Even on private systems code books were still useful. They saved time and freed up the system so more messages could be sent. From the very beginning the railways were heavy users of the telegraph (indeed it was initially designed as a railway safety system). Individual railway companies had their own code books tailored to meet their needs.<sup>3</sup> They also shared important standard words across the railway network such as EARWIG (meaning: 'following urgently required') to avoid confusion and accidents!

Coding didn't always save time, however! Being non-words, or indeed numbers (such as the popular Slater's Telegraphic Code) it was incredibly hard for the clerk to check for accuracy.<sup>4</sup> A reversed letter or missing digit would often slip through, meaning that when the message arrived at its destination it was either decoded as a different word or in some other way indecipherable. This problem was so frequent that the more popular code book producers (such as McNeill's who produced a Mining and General Telegraph Code, 1899) also published a 'terminal index', a list of code words by the order of their backwards spelling, last letter first.<sup>5</sup> The receiver of the scrambled code could work backwards through the encoded word, find the mistake and unscramble the message.

1. Williamson (Chief Superintendent), *Telegraphic Code for the Use of the Police* (London: Eyre and Spottiswoode, 1885).
2. Anon, *Unicode: The Universal Telegraphic Phrase Book* (London, Paris and Melbourne: Cassell and Company, 1894, 9th ed.).
3. Great Southern and Western Railway Company, *Code Book* (Ireland, 1901).
4. R. Slater, *Slater's Telegraphic Code to Ensure Secrecy in the Transmission of Telegrams* (London: W R Gray, 1870).
5. B. McNeill, *Mining and General Telegraph Code. Terminal Index - for use with McNeill's Code* (London: Whitehead, Morris & Co., 1899).

CATALOGUE ENTRY C7 | CODING

# CRYPTOGRAPHS AND CIPHER POST

KING'S COLLEGE LONDON ARCHIVES. K/PP107/11/1/22



Baron Lyon Playfair, great friend of Charles Wheatstone (and for whom Wheatstone's 'Playfair' cipher is named), recalls that he and Wheatstone would amuse themselves by deciphering the ciphered personal adverts in *The Times*. These were sometimes secretive business dealings but more often they were clandestine romantic correspondences. At one point Wheatstone even took out an advert in *The Times* himself to advise a young woman against the elopement she and her beau had been planning. He made sure to encrypt it in her own cipher code of course.<sup>1</sup>

The reason why Wheatstone was able to decipher these codes so easily was the frequency of certain letters or combinations of letters. In a cipher, a letter is substituted for another

letter to encode it.

A	B	C	D	E	F	G	H	I	J	K	L	M	N	O	P	Q	R	S	T	U	V	W	X	Y	Z			
			A	B	C	D	E	F	G	H	I	J	K	L	M	N	O	P	Q	R	S	T	U	V	W	X	Y	Z

In this example the key is A=D, the cipher is to move three letters further down the alphabet. This is called the ‘Caesar’ cipher (and was purportedly used by Caesar). A message reading:

THE CAESAR CIPHER IS NOT THE BEST

once enciphered would read:

QEB ZXBPXO ZFMEBO FP KLQ QEB YBPQ.

The word ‘the’ is a very common word in English so if the code cracker starts with the assumption that QEB may = THE we get the phrase:

THE ZXEPXO ZFMHEO FP KLT THE YEPT

More importantly, the cracker also notes that Q is three letters back from T, E is three letters back from H and B is three letters back from E. The key to the cipher must be therefore ‘move three letters down the alphabet’. Code cracked.

The cryptograph is designed to thwart deciphering by disguising letter – and therefore word – frequency. The device looks like the face of a clock, with a long hand and a short hand. The letters A to Z appear printed in a circle around the outside of the face. Within this is a second circle of letters, this time printed on a moveable card to enable the user to choose the key. Once the key is set, say A=D again, the big hand is pointed at the desired letter on the outer alphabet, the small hand then points to the inner, ciphered alphabet, which is copied down. Vivaly, the hands are linked to each other via a gear so that every time the big hand moves through the 26 letters of the outer alphabet, the small hand moves through 27. As the hands only turn in a clockwise direction, every time the big hand passes the 12 o’clock point, it moves the whole cipher key along one letter.<sup>2</sup> High frequency words, such as ‘the’ are therefore never enciphered the same way twice and are much harder to crack!

Wheatstone had good reason to manufacture and market the Cryptograph. Not only could it keep personal messages from prying eyes but it could also increase telegraphic traffic, as Wheatstone notes in the instruction booklet which accompanied the device:

The number of telegraphic messages relating to domestic occurrences are very much limited by the disinclination of parties to let their family affairs to be known to officials in their neighbourhood; and there can be no doubt that were this difficulty removed, this class of message would be significantly augmented, to the benefit of the telegraphic department as well as the public (Wheatstone, c.1854).

CN



1. B. Bowers, *Sir Charles Wheatstone FRS, 1802-1875*, IEE History of Technology Series, vol. 29 (London: The Science Museum, 2001).

2. Museum of Applied Arts and Science, *The Cryptograph* (2011), <http://tinyurl.com/htg39s5> (consulted 4 September 2016).



CATALOGUE ENTRY C8 | CODING

## *The Great Grammatizor: Marvellous Messaging Machine*

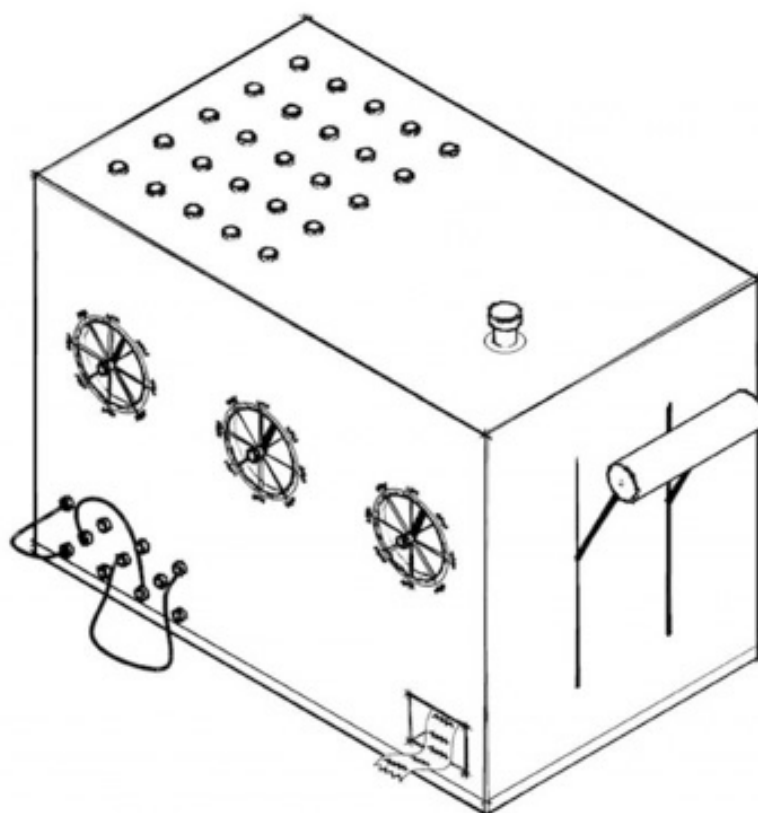

*The Great Grammatizor*, designed by Alexandra Bridarolli, was the winner of the Scrambled Messages competition to design and make an interactive message-scrambling machine which interprets ‘telegraphy’ freely. The machine, which is located in the Coding section of the exhibition, allows the public to take part in the exhibition by using the machine to produce and print a message that can be taken home.

The machine is in part an homage to the ‘Great Automatic Grammatizor’, a machine in the 1953 Roald Dahl short story of the same name. In the story, the Grammatizor is a ‘computer that will write stories’ that will eventually take over the artistic world, by being able to mass-produce great works of fiction such as novels in under fifteen minutes.<sup>1</sup> Dahl’s story, like Bridarolli’s machine, plays with the idea that grammar is a set of rules and principles that can allow a programmed machine to produce messages that can communicate meaning.

Bridarolli’s Grammatizor creates sentences using the *Exquisite Corpse* structure (from the French *Cadavre Exquis*), a creative method devised by the Surrealists in 1918 which

follows the pattern *adjective noun adverb verb adjective noun* to make sentences using chance procedures that (grammatically at least) make sense. Each member of the group would add a component to the sentence without seeing what had been written previously. Bridarolli says of her own design: '[i]f the original game is meant to be a collaborative bit of poetry, the device imagined for this project will by itself produce the message, in an interactive and didactic relationship with the public'. The machine creates poetic messages made up of words drawn randomly from user-selected categories. The user is given the choice of categories identified with to various historical periods and diverse cultural niches. The resultant mechanically-generated scrambled message may, for instance mix the tabloids with Shakespeare, chivalric romance with the absurd or science fiction with the Victorian age.

This particular device makes a great contribution to *Victorians Decoded* because of its interdisciplinary combination of technological communication and artistic creation. The idea of using existing pieces of literary construction and scrambling them to the point of abstraction echoes the difficulties of early telegraphy in which complete messages might be sent from one end and be indecipherable upon reception. However, the *Grammatizor's* messages retain the rules of grammar so that the new message created out of the bits and pieces of the old still communicates something to the user, rather than a message scrambled to complete nonsense. Victorian telegraphists hoped that with the aid of code books they could retrieve the original message from something garbled even when the message had been corrupted in the process of sending (as is seen in cat. no. C6).

Alexandra Bridarolli is a chemist by background, is completing a PhD at University College London in Conservation Science for Cultural Heritage - a field at the interface of hard science and heritage. Bridarolli worked with UCL's Institute of Making, King's College London and The Courtauld Institute of Art on the development and creation of the *Great Grammatizor*.

RS

1. Kristine Howard, <http://tinyurl.com/zz5m2y9> (consulted 17 September 2016).

F.D. 21  
6  
1845

# RESISTANCE



SHIRT.

PIECE OF PLATE.

PART OF COMPASS.

CERTIFICATE CASE.

BUTTONS,

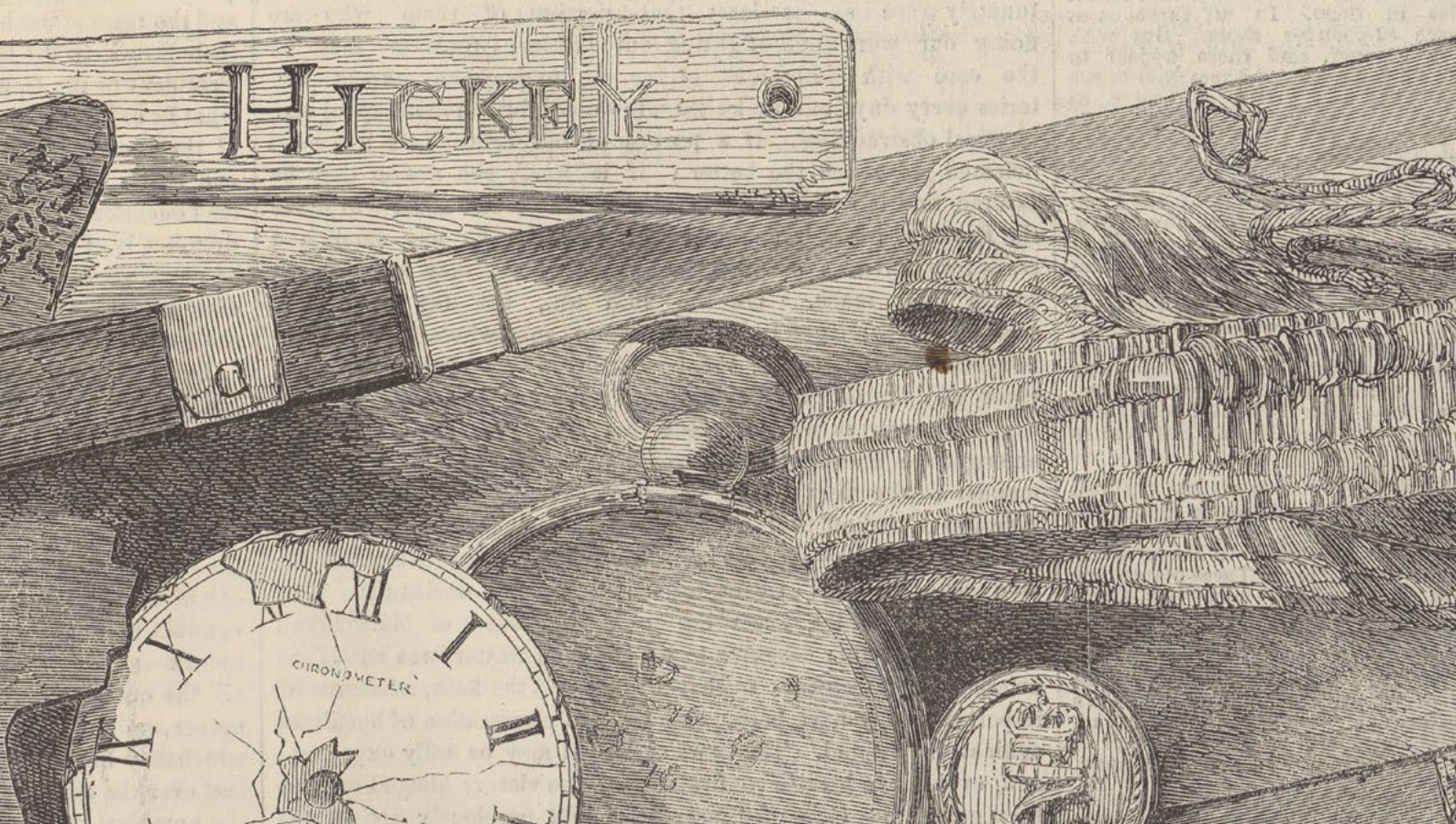

## RESISTANCE

## CLARE PETTITT

FRANKLIN'S MESSAGES: EDWIN LANDSEER'S *MAN PROPOSES, GOD DISPOSES*

Fig. 1, Edwin Landseer, *Man Proposes, God Disposes*, 1864, Royal Holloway, University of London. Image: Royal Holloway, University of London.

'Lurid' is a word which was used often in contemporary reviews of Landseer's painting 'Man Proposes, God Disposes'. *The Illustrated London News* described the action of the picture as taking place: '[u]nder the lurid sky of an arctic twilight, among the vast fantastic blocks of ice, green, or of livid pallor', and *The Times* similarly set the scene, '[u]nder the lurid light of the dawn blink and among the blocks of ice, a pair of polar bears are tugging and rending at an undistinguishable heap which was once a boat and a boat's crew'.<sup>1</sup> If the Arctic light is 'lurid' and 'livid', so were the wider associations of the picture, which critics at the time clearly identified as a commentary on the doomed Franklin Expedition.

Sir John Franklin had set off in May 1845 with two ships and 129 men to chart the Northwest Passage in the Canadian Arctic. Franklin was already famous for his privations and endurance on his two previous Arctic expeditions: the newspapers had dubbed him, 'the man who ate his boots', and his travels were disseminated in periodicals and in popular touring 'Arctic panoramas' so that Franklin's third Arctic expedition of 1845 left England in a glare of publicity.<sup>2</sup> Determined not to have to eat his boots again, Franklin had ensured that the ships were very well stocked with provisions: 32,289 pounds of preserved meat, 1,008 pounds of raisins and 580 gallons of pickles were on board. The expedition was reported as sighted by a whaling ship as Franklin's ships entered Lancaster Sound in late July 1845, and although it was subsequently seen by native Inuit people, no news would reach England of the fate of the Franklin expedition for nine years. It was only in 1854 that Dr John Rae, while travelling for the Hudson Bay Company, talked to Inuit people who reported that they had learned from other native peoples that about forty white men had been seen in 1850, dragging a boat south along the western shore of King William Island, and that later in the season the frozen bodies of those men had been found. A few years later, Captain Francis McClintock, sent out to find out more by Franklin's widow,

THE FRANKLIN RELICS.



FRANKLIN'S GUELPHIC BADGE.



MEDAL PORTRAIT OF SIR J. FRANKLIN, BY DAVIS.



FRANKLIN'S GUELPHIC BADGE.

We this week engrave the Badge of the Franklin Expedition, which was awarded to Sir J. Franklin, and were described in our Journal of last week. To them we have added an illustration of a Medal Portrait of the late Sir J. Franklin.

It is a shield with an Engraving (central star) of the Badge of the Knight Grand Cross of the Royal Hanoverian Guelphic Order worn by Franklin.

The original, by permission of the First Lord of the Admiralty. They have been preserved within a glass case, and will be preserved at the Admiralty office, as memorials of the ill-fated Expedition. The remaining articles are specified beneath the illustrations. The



PART OF FLANNEL SUIT. PIECE OF PLATE. PART OF C-WARE. GUTHRIE'S CASE. BUTTON, LINKED WITH GOLD.

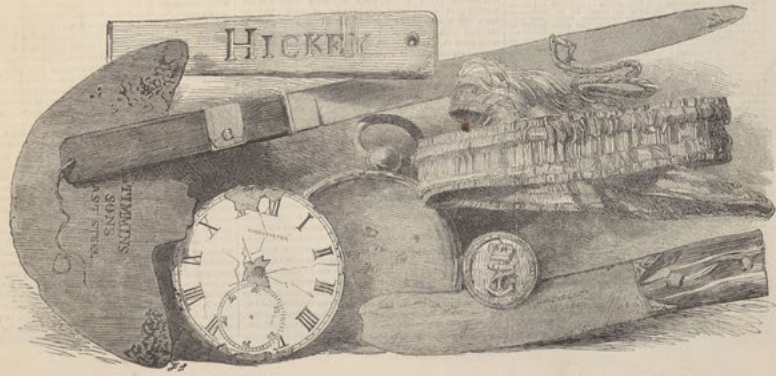

CORN'S KNIFE. KNIFE HANDLE. BUTTER. GOLD-LACE BAND. BEAN'S KNIFE.

Fig. 2, Illustrated London News (4th Nov 1854), p. 433. Photo: Wellcome Library, London.

discovered a written record of the expedition, some pieces of personal property belonging to the crew, and the skeletons of some of the men.<sup>3</sup> McClintock sent a confidential report to the Admiralty, '[f]rom the mutilated state of many of the bodies, and the contents of the kettles, it is evident that our wretched countrymen had been driven to the last dread alternative as a means for sustaining life'.<sup>4</sup> This report of cannibalism among Franklin's crew was leaked to the press, and, perhaps as a consequence, McClintock's subsequent book, *The Voyage of the 'Fox' in the Arctic Seas: A Narrative of the Discovery of the Fate of Sir John Franklin and His Companions* ran rapidly through six editions. McClintock included an 'Appendix' which gave a comprehensive list of all the miscellaneous material remains that he had discovered: 'a small bead purse, a piece of red sealing-wax, stopper of a pocket flask, German silver top and ring, brass matchbox, one of the glasses of a telescope, a small tin cylinder, probably made to hold Lucifer matches .... Five watches'.<sup>5</sup> McClintock provided colour plates of these objects, and they were widely reproduced in periodicals in Europe and America (Fig. 2). Landseer's picture shows a telescope lying on the ground, a notebook, a tatter of blue serge from a naval uniform, and a ragged red flag. The *Athenaeum* was explicit in connecting Landseer's picture of 'an Arctic incident' to McClintock's book, saying the subject was 'suggested by the account of finding relics of the Franklin Expedition', although it also felt that the picture was tasteless, '[a]s to his choice of subject, we protest against it'.<sup>6</sup> The *Illustrated London News* agreed that the subject was possibly 'too purely harrowing for the proper function of art'.<sup>7</sup>

Why did the picture appear tasteless and lurid? Why did it elicit such strong reactions when it was exhibited at the Royal Academy Exhibition in May 1864? At the opening of the Exhibition, Franklin's widow refused to enter the room in which the 'offensive' picture was hung, whereas she had been part of an illustrious group of 'Arctic luminaries' celebrating the opening of American Frederick Church's elaborately orchestrated show of his large canvas *The Icebergs* (Fig. 3) at the German Gallery in London the year before.<sup>8</sup> Landseer's portrayal of the Polar bears chewing on the bones of the dead explorers was graphic and uncompromising, for sure, but it also shocked by obliquely evoking the allegation of cannibalism among the survivors. Lady Franklin had asked no less a powerful figure than Charles Dickens to refute these stories in his immensely popular journal, *Household Words*, and he had done so, strenuously dismissing, 'the wild tales of a herd of savages'.<sup>9</sup> With his friend, Wilkie Collins, Dickens subsequently reimagined the Franklin expedition as a heroic tale of manly sacrifice in their jointly-authored play, *The Frozen Deep* (1856). Recent research has established that the survivors of the Franklin expedition did, indeed, eat their dead colleagues, just as the Inuit had reported.<sup>10</sup>



Fig. 3. Frederic Edwin Church, *The Icebergs*, 1861, Dallas Museum of Art, gift of Norma and Lamar Hunt, 1979.28. Image courtesy Dallas Museum of Art.

It was Alfred Tennyson who famously wrote of ‘Nature red in tooth and claw’ in his long poem of loss and grief for his friend Arthur Hallam, *In Memoriam A.H.H.* By the time the poem was published to enormous acclaim in 1850, Tennyson was Poet Laureate, and the Franklin expedition had been missing for five years. The colour red, and teeth and claws would all feature in Landseer’s remarkable canvas which, like Tennyson’s poem, pits the amoral logic of the wild against the survival and endurance of the human, ‘the two white polar bears feasting in ghastly voluptuousness on the bones of our lost seamen, amongst great opalescent masses of ice’.<sup>11</sup> Like Tennyson in *In Memoriam*, Landseer also uses scale to dramatic effect in his eight-foot wide canvas and this was also noticed at the time as critics described the ‘great...masses of ice’; ‘cold mountains of ice, vast and desolate’ and ‘the wild, desolate, icy desert’.<sup>12</sup> But it is not just scale but also substance that has fatally blocked Franklin’s attempt to establish a northern route from the Atlantic to the Pacific. The painting insists on the recalcitrance of a densely material world massed against puny human force. In the 1860s, materialism, the idea that the world exists only as material and has no spiritual form or purpose, seemed to some to be the fearful and logical consequence of Darwin’s recently published ideas of evolution and survival.<sup>13</sup> Tennyson’s *In Memoriam* is already haunted by the appalling meaninglessness of materialism, as when he asks if the mortal remains of his friend are to ‘Be blown about the desert dust, / Or seal’d within the iron hills’.<sup>14</sup> The rhyming in Landseer’s painting of the bones of the human ribcage and the wreckage of the wooden vessel suggests a disturbing structural similarity between these dead materials. The reduction of human life to mere substance or matter, the lack

of spiritual agency, and the dizzying power of the natural environment to disperse or absorb human meaning: all of these return forcefully in Landseer's Polar landscape.

The *Athenaeum* registered the immensity of Landseer's *Man Proposes, God Disposes* when it admitted that, 'it would be pedantry to reserve consideration of its merits until we come to the class of paintings of animals'. Landseer was famous for his moralised portraits of anthropomorphized animals, such as *Dignity and Impudence* (1839) (Fig. 4), but in his later work he is moving away from this genre, as was half-noticed at the time. Of the Polar bears in his 1864 canvas, the *Reader* asked, '[w]hich of us...has ever seen so deeply into [the Polar bears'] nature as to conceive with magical truthfulness the very conditions and course of their lives, and their relationship to the barren desolation and wilderness of ice in the midst of which they were born and nurtured'. William Rossetti noted this shift too, 'it places the painting of brute life upon a new and higher platform, hardly inferior in lofty suggestiveness to human subjects'.<sup>15</sup> It is precisely because the bears are *not* moralised and emphatically not anthropomorphised that the picture troubled many contemporary viewers. The picture reverses the logic of Landseer's earlier paintings. Instead of asking us to understand an animal from a human perspective, Landseer rather asks us to understand the world from a Polar-bear perspective, and in so doing, forces us to understand that in this environment and from this point of view the human is nothing but irrelevant carrion. The Polar bears are shown simply doing the things that Polar bears do.

Broken and failed communication was very much in the public mind in the early 1860s. The Franklin expedition was attempting to open up a new channel of marine communication between the Atlantic and the Pacific oceans. Landseer represented its dramatic failure just as the failures of the repeated attempts to lay a Transatlantic Telegraph Cable were being reported in the press. One of the problems of the first transatlantic cabling attempts was the enormous resistance of the 2,754 km-long cable. The cable project elicited new research on electrical resistance. Resistance is a property of all materials and denotes how difficult it is to push electricity through them. High resistance is a good thing for an insulator (e.g. gutta-percha), but conductors need low resistance (e.g. copper). Too much resistance makes it impossible to get a current, or in telegraphic terms, a message, through. The recalcitrant landscape of Landseer's painting has blocked and obstructed the passage of Franklin's route-finding mission. The torn flag, the red British Naval Ensign, is suggestive of spilt blood on the snow, but it is also eloquent as a failed signal. Art historian, Diana Donald has argued that this flag stands in for 'a deliberate tearing of the fabric of patriotic rhetoric'.<sup>16</sup> Tension was another vital concept for nineteenth-century telegraphy, as too much tension could snap the cable, but too little could cause it to tangle and retard its proper functioning. Landseer visualizes tension in the pull of the Polar bear's teeth on the taut red flag that reminds us of the material properties of the wreckage and their breaking points.





DIGNITY AND IMPUDENCE.

Fig. 4, Georg Zobel, Edwin Landseer, *Dignity and Impudence*, mixed method engraving, published London: Graves & Co., 1871, image: ©Trustees of the British Museum.

The *Reader* felt that Landseer's painting 'lifts the veil of distance from our eyes' and the *Athenaeum* agreed that, 'a purple veil of mist is drawn aside – as if a secret were displayed, and in order that we might see what became of our long-lost countrymen'. Swinburne's 1860 poem 'The Death of Sir John Franklin' similarly meditates on distance, the passing of time, and delayed communication:

So winter-bound in such disastrous place,  
 Doubtless the time seemed heavier and more hard  
 Than elsewhere in all scope and range of space;  
 Doubtless the backward thought and broad regard  
 Was bitter to their souls, remembering  
 How in soft England the warm lands were starred  
 With gracious flowers in the green front of spring

Swinburne's poem inhabits a disjunctive double-time when all communications were impossible for Franklin and his stranded crew, so that back in Britain, 'No man made count of those keen hopes and fears/ Which were such labour to them'.<sup>17</sup>

When McClintock discovered the remains, human and inanimate of the expedition, they were so well-preserved by the cold that it was as if he had found a message that had been stored for a long time, and he was finally able to transmit it.<sup>18</sup> The message that he discovered was scrambled: it was unclear what exactly had happened to the men, although their disastrous end was clear. The dispersed and incongruous fragments of the expedition: human bones and bone-handled knives, sealing-wax, skulls half eaten by animals and the glass from a telescope cannot coalesce into a story, scattered out of time and out of sequence. Landseer's painting therefore likewise resists coherent narrative. William Rossetti called the relics that featured in Landseer's painting, 'the saddest of *membra disjecta*' because he saw that *Man Proposes, God Disposes* shows us a history that has been scrambled and dispersed by nature.<sup>19</sup> In the entanglement of arctic, bear, and man, Landseer shows us how geological, zoological and climatological factors are part of the making of a history that can not always be understood as exclusively 'human'.<sup>20</sup>

1. 'Fine Arts: Exhibition of the Royal Academy', *Illustrated London News* (7 May 1864), p.454 and 'Exhibition Of The Royal Academy', *The Times* (30 April 1864), p. 14.
2. Scott Cookman, *Ice Blink: The Tragic Fate of Sir John Franklin's Lost Polar Expedition* (New York: John Wiley and Sons, 2000), p.23.
3. See B. A. Riffenburgh, 'Sir John Franklin', *Oxford Dictionary of National Biography* <http://tinyurl.com/jolsj2q> (consulted 1 September 2016). For further details see also Francis Spufford, *I May Be Some Time: Ice and the English Imagination* (London: Faber & Faber, 1996); Owen Beattie and John Geiger, *Frozen in Time: The Fate of the Franklin Expedition* (London: Bloomsbury Press, 1987); Janice Cavell, *Tracing the Connected Narrative: Arctic Exploration in British Print Culture 1818-1860* (Toronto, Buffalo, London: University of Toronto Press, 2008); some of the Franklin relics that are held by the Royal National Maritime Museum at Greenwich can be seen online: <http://tinyurl.com/h2vudqk> (consulted 1 September 2016).
4. 'John Rae', *The Oxford Book of Exploration*, selected by Robin Hanbury-Tenison (Oxford: Oxford University Press, 2005), p.298.
5. Francis McClintock, *The Voyage of the 'Fox' in the Arctic Seas: A Narrative of the Discovery of the Fate of Sir John Franklin and His Companions* (London: John Murray, 1859), p.286.
6. 'The Royal Academy', *Athenaeum* (May 7, 1864), p.650.
7. 'Fine Arts: Exhibition of the Royal Academy', *Illustrated London News* (7 May 1864), p.455.
8. Ken McCoogan, *Lady Franklin's Revenge: A True Story of Ambition, Obsession and the Remaking of Arctic History* (Toronto: HarperCollins, 2005), p.478.
9. Charles Dickens, 'The Lost Arctic Voyagers', *Household Words*, vol. 10 (2 December 1854), p. 363.
10. For recent archaeological evidence of cannibalism on the expedition see: <http://tinyurl.com/hoeyg5u> and <http://tinyurl.com/zgd3z25> (consulted 1 September 2016).
11. 'Exposition Universelle de 1867 a Paris', *Quarterly Review*, vol. 29.57 (October 1867), p.96.
12. 'The Royal Academy', *Art Journal* (June 1864), p.168 and 'The Royal Academy', *London Review of Politics, Society, Literature, Art, and Science*, vol. 8:201 (7 May 1864), p.487.
13. Although Darwin himself refuted the materialism of his theories.
14. Alfred Tennyson, *In Memoriam A.H.H.*, LVI, line 15 and lines 19-20.
15. W. M. Rossetti, 'Art Exhibitions in London', *Fine Arts Quarterly Review*, vol. 3 (October 1864), p.23.
16. Diana Donald, 'The Arctic Fantasies of Edwin Landseer and Briton Rivière: Polar Bears, Wilderness and Notions of the Sublime', <http://tinyurl.com/zlhy9gp> (consulted 1 September 2016).
17. Algernon Charles Swinburne, 'The Death of Sir John Franklin' in *The Complete Works of Algernon Charles Swinburne, Poetical Works* (London: W. Heinemann Limited, 1925).
18. Adriana Craciun has recently read the far-away Arctic as an 'eclectic archive...comprising religious, navigational, institutional, textual and personal detritus, publicly referred to as "the Franklin relics"'. Adriana Craciun, *Writing Arctic Disaster: Authorship and Exploration* (Cambridge: Cambridge University Press, 2016), p.34.
19. W.M. Rossetti, 'Art Exhibitions in London' (1864), p.23.
20. Benjamin Morgan has written that, 'entanglements of human action with geological and climatological events [can be] understood as motive forces of history'. Benjamin Morgan, 'After the Arctic Sublime', *New Literary History*, vol. 47 (2016), p.2.

RESISTANCE

# NATALIE HUME

RESISTANCE AND BOUNDARIES: PETER GRAHAM'S *RIBBED AND PALED IN BY ROCKS UNSCALEABLE AND ROARING WATERS*



Fig. 1, Peter Graham, *Ribbed and Paled in by Rocks Unscaleable and Roaring Waters*, 1885, Guildhall Art Gallery, City of London Corporation.

The location of this painting of untrammelled nature, located in the part of the exhibition that explores resistance, acts as a reminder that electricity is a natural as well as a man-made phenomenon, and that its behaviour can be inconvenient, frustrating and dangerous. Electrical resistance is the opposite of conductance, a gauge of how difficult

(or easy) it is for a current to pass through a medium. Resistance is a result of both material and form: the core of the transatlantic telegraph cable was made of copper, which is a good conductor with low resistance, but the core had to be thick because resistance increases as diameter decreases. As well as in the context of electricity, resistance is a term used extensively within physics, as in thermal or geological resistance for example. Resistance is also a word with a range of meanings in other contexts, including politics, the military and psychoanalysis. The connotations of the word shifted following its specific usage in the Second World War for the French Resistance to the Nazi occupation, while more recently there has been growing concern about the phenomenon of pathogens' acquired resistance to antibiotics. Returning to nineteenth-century usage, a Google Ngram shows that 'resistance' appeared ever more frequently in published English between 1870 and 1895, a period of growing imperialism matched by heightening unrest overseas.<sup>1</sup> During this period the term was also used in a more general military context, as well as for electrical and geological resistance. This multivalence is relevant because it demonstrates the way that electrical resistance participates freely in intercontextual relationships, lending itself to metaphor, analogy and mapping.

*Ribbed and Paled by Rocks Unscaleable and Roaring Waters* is one of a series of unorthodox paintings depicting the coast of the Scottish Highlands. As a wild, dramatic landscape it references the sublime, but in place of the conventional awe-inspiring view, lavishly depicting a mountain peak or great valley, it offers an uncompromising wall of rock and bad weather, fierce yet understated. The low, myopic viewpoint, causing the rock to loom ominously over the scene, elicits an abject rather than an exhilarated response; and for a Western audience accustomed to reading towards the right, the position and scale of the dark cliff is profoundly threatening, frustrating the eye. The unusual framing is emphasised by the portrait format and a distorted, vertically stretched perspective, so that the viewer has the impression of looking straight at the side of the cliff and simultaneously down into the turbulent sea.

These subtle resistances of form – to genre and convention – are compounded by the distinct visceral resistances offered by the three materials: the cloud is a heavy, wet curtain obscuring the horizon; the waves are made opaque by their powerful currents; and the hard rock is broken by angular fissures etched over centuries. Each of the three elements exerts a force upon the others, illustrating a slow, massive, endless struggle for geological supremacy. The resistance between the different elements depicted, though, is secondary to the one that meets the viewer. Fields of cloud, sea and rock – gas, liquid and solid – form a layered, impenetrable skin. Their interaction is seamless: the pattern made by the illumination of the rain in the sky is echoed by the sea foam, while the pocked surface of the rock is a gradually evolving imprint of the rushing water and pounding rain. The severely limited palette, dominated by black, white and grey, enhances the scene's

austere harmony.

On one level, Peter Graham's painting – an apparently direct, detailed representation of a windswept, coastal view – embodies resistance by resisting interpretation. There are no people, whose dress and body language would offer a narrative, and each bird and natural feature is authentic, without intrusive symbolism or obvious significance. The uncompromising, closely described landscape suggests Graham's affinity with recent trends in British art, going back via John Ruskin's 'truth to nature' and the Pre-Raphaelites' *plein-air* practice to the stormy skies of John Constable and J. W. M. Turner. One critic, however, comparing the painting unfavourably with the looser brushstrokes of the French Impressionists, complained that Graham 'offers, in place of outdoor work direct from nature, the artifice of the studio'.<sup>2</sup> This accusation implies that there is something disingenuous about the careful selection and portrayal of this particular stretch of coast under these weather conditions; that the brutality on the canvas is something more than a trace of the environment's indifferent resistance to the artist.

The oblique title leaves no doubt that this is indeed the case. It deliberately connotes the violent power of the elements with their painful laceration of pallid human flesh and brittle bone, although the body is mentioned directly neither in word nor in image. The title also introduces humanity via a cultural framework, since it quotes the English Queen in Shakespeare's *Cymbeline*, persuading her husband to fight Roman taxation:

Remember, sir, my liege,  
 The kings your ancestors, together with  
 The natural bravery of your isle, which stands  
 As Neptune's park, ribbed and paled in  
 With rocks unscalable and roaring waters,  
 With sands that will not bear your enemies boats,  
 But suck them up to the topmast.

(*Cymbeline*, Act III, scene 1)

This appeal to the King's self-importance convinces him to challenge Roman law, putting England in jeopardy. In light of this reference, the wall of rock suggests a national border, while the birds across the surface of the rock stand for citizens oblivious to the royal drama endangering their lives.

Cymbeline's mistake, persuaded by his wife and stepson to embrace vainglorious nationalism and nostalgia while neglecting tactical diplomacy, resonates strikingly with the recent UK 'Brexit' fiasco. It must have offered an equally relevant comment upon Britain's international status in the 1880s, a period of rapid imperialist growth accompanied by tension with other colonial nations and committed challenges from a range of colonised peoples. In the twenty years prior to 1885, when Graham produced this painting, there

had been resistance to British settlers from indigenous populations in Australia and New Zealand (1860s and 1870s), the fighting of the Second Anglo-Afghan War (1878–1880) and the early years of the long and violent ‘Scramble for Africa’ (from the 1880s). There was also organised opposition to British rule in Ireland and India during the mid-1880s.<sup>3</sup> Ancient Roman imperialism offered a useful analogy for British expansionism throughout this period, particularly for those critical of the brutality and waste that were the corollary of aggressive foreign policy.

Graham identified strongly as Scottish rather than British, with his work consisting overwhelmingly of representations of wild Highland landscapes. In light of this, the quotation may have expressed sympathy with the position of the Queen in *Cymbeline*, comparing the present-day pseudo-colonial relationship between Scotland and England with England’s previous subservience to Ancient Rome. From the middle of the nineteenth century Scotland’s growing industrial success and increasingly confident political and cultural identity (following the international success of Walter Scott, for example) led to calls for Home Rule; these were met with a compromise in 1885 – the year Graham made this painting – when Prime Minister Lord Salisbury revived the post of Secretary of State for Scotland. In an alternative reading, the Queen’s words emphasise the natural isolation of the British Isles, surrounded by treacherous rocks and rough seas; Graham might be inverting this observation, querying the wisdom of violating the nation’s inherent geographical seclusion in the pursuit of power and influence abroad.

In any case, it seems that the challenging, uncompromising landscape of Scotland provided Graham with a useful political metaphor, and it is likely that his outlook was specifically Scottish rather than British. He frequently depicted rushing water and wild coastal weather, as in *Lashed by the Wild and Wasteful Ocean* (n.d., Temple Newsam House, Leeds), for example, which shares a compositional structure with *Ribbed and Paled*: sea, sky, cliffs and birds, as well as a Shakespearean reference.<sup>4</sup> *An Iron Bound Coast* resembles *Ribbed and Paled* even more closely, with its obdurate wall of dark rock rising to the right and thick stormy sky. Its title emphasises the moated geographical isolation that colours the rhetoric of *Cymbeline*. After the Roman envoy has been denied his taxes, Cymbeline’s scheming stepson Cloten cannot resist provoking the ambassador further:

... Make  
 pastime with us a day or two, or longer: if  
 you seek us afterwards in other terms, you  
 shall find us in our salt-water girdle: if you  
 beat us out of it, it is yours; if you fall in  
 the adventure, our crows shall fare the better  
 for you; and there’s an end.

(*Cymbeline*, Act III, scene 1)

The 'salt-water girdle' describes a natural enclave, affording strong defence but not necessarily encouraging foreign expansion. In the wake of the emergence of geology as a science, heated debate over the continuing relevance and accuracy of Christian doctrine had heightened the place of symbolism and ideology in landscape painting. The Shakespearean reference underscores Graham's apparent depiction of a Godless world, in which Nature is harsh and merciless and man must struggle for survival as well as self-determination.



Fig. 2, Peter Graham, *An Iron Bound Coast*, 1872, Atkinson Art Gallery Collection, Southport, image © The Atkinson, Southport

The mention of murderous crows, too, would seem to cast the seabirds in *Ribbed and Paled* in a sinister light, but their participation in the scene is much more ambivalent than Cloten's words would suggest. Graham has faithfully represented cormorants, guillemots, kittiwakes and common gulls, all species that colonise Scottish coastal cliffs. Regardless of their alien, almost prehistoric appearance, these birds are the only living creatures depicted, aside from some primitive splashes of lichen on the rocks. Populating an otherwise uninhabitable terrain and gazing out to sea, the birds stand in for human intelligence. Graham, an avid painter of local nature, was likely to be well aware that most seabirds return to one breeding site every year, and gulls tend to mate for life. The birds' connection to place and to one another gives them a fellowship with humanity too, particularly in connection to *Cymbeline* and its preoccupation with political and familial allegiances and betrayals.



Cloten's image of a girded island chimes with another Shakespearean quotation, when Puck promises Oberon, 'I'll put a girdle round about the earth/In forty minutes' (*A Midsummer Night's Dream*, Act II, scene 1). This couplet was frequently alluded to in nineteenth-century commentary on the telegraph, for example in an 1858 poem by T. Buchanan Read: 'Speed, speed, speed the Cable; let it run,/ A loving girdle round the earth,/ Till all the nations 'neath the sun/ Shall be as brothers at one hearth'.<sup>5</sup> This Utopian vision channels the supernatural speed of Puck, in stark contrast to Cloten's girdle as impenetrable moat guarded by aggressive birds.

Shakespeare's girdle, then, facilitates Puck's longitudinal travel, affording frictionless efficiency through its length like electricity passing through a thick copper cable, but in another context (the encirclement of an island) the girdle becomes a moat or barrier to thwart transverse passage. These properties correspond interestingly with the technical functioning of the telegraph cable. The result of minimising resistance along the cable's length was that electromagnetic induction increased, causing distortion of the signal.<sup>6</sup> In this process, the large longitudinal current flow enhanced the electromagnetic field surrounding the cable (a force that was effectively transverse, orbiting the main direction of current). The interaction of current and field produced additional voltage, with the troublesome effect that messages lost their clarity and became difficult to decipher. Such effects had to be mitigated using a variety of means, including the introduction of capacitors.<sup>7</sup> In Graham's paintings, the clashing range of currents suggests something of this complexity and negotiation: not only does the water travel around the coast, but it swirls, splashing and dispersing as it dashes against the rocks. As with electrical induction, these splashes and swirls are liable to increase with the magnitude of the current around the coast.

The tension between free flow and interference also reflects the telegraphic project more generally. Its initiators encountered resistance from cynics, while cable engineers had to grapple with logistical challenges such as difficult terrain and stormy weather as well as electrical resistance and induction, both in laying the cable and in maintaining it as demand increased. The effects of telegraphy, too, involved improvements in some capacities but created new problems in others: for example, communication was much faster, but often less detailed and more vulnerable to error and misinterpretation; and while the telegraph was hailed as an aid to peaceful diplomacy, it equally offered new opportunities for espionage and sabotage.

*Ribbed and Paled* is an apparently naturalistic portrayal of a wild, stormy landscape, inert to interpretation and resistant to occupation. If the sublime is a landscape suffused with the majestic power of God, Graham's painting evokes a natural world in which God

– like humanity – is conspicuous by His absence. As such it appears to offer an image of consummate resistance to human presence, a world without meaning or purpose; even its portrait format seems to act as a full stop. But resistance can be useful in its obstructiveness. Many electrical devices, such as those for measuring voltage, work using resistance. The violent, impassable water around Graham's coast may look impassable, but it acts as a conduit: it not only demonstrates his skill and dedication as an artist, but participates in a complex and apparently uninhibited flow of meanings. Like Shakespeare's girdle, the picture can be approached as a simple landscape or as a relatively frictionless 'open text'. In promiscuously transcending context and crossing boundaries, this unpeopled scene is inscribed with layers of human association in the form of references to geography, politics, science and literature. The painting's ostensible resistance – from its hostile terrain to the implicit challenges it poses to its audience – nevertheless invites interpretation and extrapolation. Like the telegraphic network as a whole Graham's painting has both a resistant face and layers of fluent connections.

1. The Ngram can be found at <http://tinyurl.com/h28hyn7> (consulted 31 August 2016). For an example of 'resistance' used in an imperial context during the 1880s: 'Within these limits British authority is for the time established, and may be maintained by the punishment of offences, including that of resistance to the ruling power'. 'The Hanging Policy', *The Friend of India & Statesman*, no. 2,345 (28 January 1880), p. 78.
2. *Blackwood's Magazine*, vol. 138, no. 837, (July–December 1885).
3. A failed bill to establish Home Rule in Ireland was put to Parliament in 1886. The Indian National Congress was founded by seventy professionals and intellectuals in 1885.
4. The phrase 'Swill'd with the wild and wasteful ocean' occurs in Act III, scene 1 of *Henry V*.
5. T. Buchanan Read, 'The Cable', *The Living Age, Third Series*, vol. 2 (July–September 1858), p. 831.
6. For a straightforward definition of electromagnetic induction, see Wikipedia: 'Electromagnetic or magnetic induction is the production of an electromotive force or voltage across an electrical conductor due to its dynamic interaction with a magnetic field'. [https://en.wikipedia.org/wiki/Electromagnetic\\_induction](https://en.wikipedia.org/wiki/Electromagnetic_induction) (consulted 1 September 2016).
7. For a straightforward definition of capacitors, see Wikipedia: 'A capacitor (originally known as a condenser) is a passive two-terminal electrical component used to temporarily store electrical energy in an electric field. ... In electric power transmission systems [capacitors] stabilize voltage and power flow'. <https://en.wikipedia.org/wiki/Capacitor> (consulted 5 September 2016).

## RESISTANCE

## CASSIE NEWLAND

## GUTTA-PERCHA

Gutta-percha is a natural plastic that was employed by telegraph cable manufacturers to insulate the copper core of the cable. It is a tree sap, which when heated becomes plastic and workable into almost any shape. Importantly, gutta-percha retains this new shape as it cools and hardens to a consistency like thick leather. It is thought that the cabinet of curiosities collected by John Tradescant in 1656 contained a sample of gutta-percha described as ‘mazer wood’ and that ‘being warmed in water [it], will work to any form’.<sup>1</sup> From Tradescant’s Cabinet to the mid nineteenth century gutta-percha remained nothing more than a little-known curiosity.

Michael Faraday first published observations on the electrical properties (or rather the lack of them) of gutta-percha in a letter to the *Philosophical Magazine* dated 1 March 1848. He finds gutta-percha to be an excellent insulator and suggests multiple uses for it in the manufacture of electrical equipment and the undertaking of electrical experiments.<sup>2</sup> The idea of insulating copper wires with it appears to have been made by William Henry Hatcher, Civil Engineer and Secretary of the Electric Telegraph Company who in 1846 had suggested its possibilities for insulating cable to Charles Vincent Walker, Electrician to the South Eastern Railway company.<sup>3</sup> In 1847 Walker, along with J. & T. Forster and Co., patented a machine which sandwiched copper wire between two fillets of gutta-percha.<sup>4</sup> Walker is also credited with mentioning gutta-percha’s insulating potential to Charles Hancock of the Gutta Percha Company who in 1848 designed a superior machine for covering wires seamlessly through a process of extrusion.<sup>5</sup> Other early adopters were Werner von Siemens, who is credited with insulating an experimental wire with gutta-percha in 1847.<sup>6</sup> These early insulated cables were so effective that gutta-percha became a very sought-after material.

The tree is described as ‘a tree of large size, attaining a diameter of 4 to 5 feet, and a height of between 100 and 200 feet... It has large thin buttresses around its base.’ It is slow-growing and gutta-percha cannot be harvested until the tree is around 30 years old.<sup>8</sup> Gutta-percha is traditionally harvested by felling the entire tree, rather than tapping as is commonly practiced with other sap-producing trees, such as rubber. The tree is felled several feet from the ground using a *biliong* or axe. The bark of the trunk was then ringed at intervals of approximately 15 to 30cms to allow the latex to run out and the crown removed to encourage the flow. Coconut shells, leaves or a hole in the ground were used to collect the dripping sap. Each tree produced very little (gutta-percha coagulates very quickly on exposure to the air) and the vast majority of the gutta-percha remained undrained inside the trees. Tully estimates that as little as 11 ounces (312g) of latex could be gathered on average from any one tree.<sup>9</sup>

As Collinsestimates British imports for 1877 alone as 1.34 million kilograms (approximately 4 million trees)<sup>10</sup> and Sérullas gives the figure for 1891 at a staggering 1.8

million kilograms (5.5 million trees), the traditional method of gathering quickly became unsustainable.<sup>11</sup> Scarcity drove prices through the roof. In 1844, before its discovery by the telegraph industry, gutta-percha was eight Spanish Dollars per *picul* (60 kilos).<sup>12</sup> By 1848, shortly after its debut as an insulator, it had risen to 13 Spanish Dollars per *picul*. By 1853, after the successes of the first gutta-percha insulated cables the price rocketed to 60 Spanish Dollars per *picul*.<sup>13</sup> The extraordinarily high price that the material commanded meant that every gutta-percha tree was effectively subject to a bounty. Collection soared and the tree was soon facing threats of extinction.

Gutta-percha was extinct on Singapore island by 1847,<sup>14</sup> from Malacca and Selangor by no later than 1875 and from Perak region by 1884.<sup>15</sup> When supplies were exhausted from British territories, the telegraph industry turned to imports from Borneo and Sumatra. In 1879 alone five million trees were cut down for their gutta on the island of Borneo.<sup>16</sup>

But cables were changing the world. Demand continued to soar. The British government, one of the greatest beneficiaries of the submarine cables, found itself increasingly addicted to a product over which it had little influence. Worries were voiced constantly and from the inception of the export industry about the unsustainable nature of the local collecting industry, the lack of foresight and the unmanaged and unmanageable forest system. Future supply problems were predicted 'if some more provident means be not adopted in its collection than that at present in use'.<sup>17</sup> The boom in the cable industry in the 1870s exacerbated the situation leading to calls to action from many writers including Collins,<sup>18</sup> Brannt<sup>19</sup> and telegraph engineer Séligmann-Lui.<sup>20</sup>

The powerhouse of economic botany, Kew, was mobilised into action to search for new sources of the rapidly disappearing plant. It quickly established that gutta-percha trees will only grow, on a narrow strip of land encompassing The Malay peninsular, Sumatra and what was the island of Borneo (today comprising Sabah, Sarawak, Brunei and the various Kalimantanans). Once this extremely limited ecological band in which gutta trees grew naturally became known waves of panic spread throughout the telegraph industry.<sup>21</sup> Faced with a finite and rapidly shrinking natural resource the scientists at Kew turned to other, more imaginative means of continuing supply.

Kew requested – and were sent – thousands of specimens of gutta sapplings, leaves and seeds from all over the world. These were then sorted, identified, catalogued and named by William Hooker, Director of the Royal Botanic Gardens, Kew.<sup>22</sup> This allowed the collation and dissemination of information about exactly which species of gutta-producing trees were suitable for use as a telegraph insulator. It also reduced the amount of inferior gums accidentally entering the export market, allowing for identification and assessment of imported gutta samples in terms of their purity and likely properties. The impact

of identifying the correct tree for gutta-collection brought with it more selective felling, further impacting the *Palaquium gutta*.

The network of botanical and experimental Gardens was galvanized into action as Kew sought further regions in which *Palaquium gutta* would grow to increase supply. Seeds of the *Palaquium Gutta* were packed into tins and envelopes and sent out to the far reaches of the Empire. To no avail, in the *List of Economic Plants Native to or Suitable for Cultivation in the British Empire* gutta-percha is still listed as suitable for growing only in the British territory of Malaya and the foreign territories of Sumatra and Java.<sup>23</sup> Kew then attempted to find a suitable substitute tree that *could* be grown in British territories, trying *Bassia parkii* in British Africa, *Mimusops balata* in the Guianas (Royal Botanic Gardens, Kew, 1891) and *Dichopsis elliptica* in India.<sup>24</sup> The Kew Bulletin notes that without exception the gum from these plants failed as potential electrical insulators.<sup>25</sup>

With no good news from Kew, the British Government knew their only hope to maintain supply was to increase British presence in the growing region and create gutta-percha plantations. When gutta-percha first appeared on the market Britain held three, relatively small, trading colonies on the Malay peninsula: Penang Island, Province Wellesley, and Malacca and Singapore; an area of approximately 1276 square miles. Sarawak, on the north-west coast of the island of Borneo was also nominally under British 'White Raja' rule. In 1846 the Sultan of Brunei was persuaded to cede Labuan island off the Sabah coast to the British. In 1874 Pangkor island, the Dindings and Province Wellesley on the Malay peninsula were also ceded to the British. Finally, in 1881 the British North Borneo Company was formed with lands of 30 000 square miles encompassing the present day area of Sabah.

Even with territory established in the growing region, gutta-percha plantations were not easily encouraged. The unsuitability of the tree to less invasive 'tapping' methods and the slow growing nature of the plant ensured that any gutta-percha plantation would not realise any profit on the initial investment until the trees were mature; a delay of at least 30 years. Investors were understandably slow to appear while there existed an exploitable supply in the wild.<sup>26</sup> When prices finally went through the roof, around 1895, plantations became an economically viable prospect for first time. The first was set up by the Dutch in Java in 1895, which produced gutta from 1908.<sup>27</sup> The British followed in 1915 with production coming online in the late 1920s. Plantations were never to become even remotely successful at meeting demand; a case of too little too late.

Running in parallel to this typically imperial government enterprise was a stream of research being carried out in the laboratories of the cable manufacturers. Sérullas, for example, patented a process to recover gutta by macerating fallen leaves and twigs

then treated them with acid to recover the gum.<sup>28</sup> Attempts were also made to replace gutta-percha as an insulation material entirely. Thomas Christy, for example patented a 'bandage of animal glue and glycerine'<sup>29</sup> which could be used to cover cables, while Purcell Taylor invented 'Purcellite', the artificial gutta-percha.<sup>30</sup> Both these substitutes sank without a trace.

The most promising developments came at the turn of the nineteenth century in places such as TELCON. A nascent chemical industry emerged.<sup>31</sup> This industry worked with lower quality (read cheaper and more abundant) guttas. The individual chemical compounds comprising true gutta were slowly identified to provide an ideal recipe of resins, gums and plasticisers. Engineers could then use this recipe to manipulate lower quality guttas, removing unwanted elements and substituting the missing ingredients with ones derived from petrochemicals. More sophisticated understandings of the properties of materials rapidly developed and it was a short journey from manipulating existing materials to the synthesis of entirely new ones. In 1898 the first man-made plastic, polyethylene, was created. It would go on to replace gutta-percha as an electrical insulator. The Malaysian and Indonesian rainforests, having been selectively plundered began a slow decline. The days of gutta-percha were over, a victim of the telegraph engineer's success.

1. Tradescant quoted in T. Oxley, 'Gutta Percha', *Journal of the Indian Archipelago and East Asia* (1847), p. 29.
2. M. Faraday, 'On the use of gutta-percha in electrical insulation', *Philosophical Magazine*, Series 3, vol. 32, no. 214 (1848), p. 165.
3. In the nineteenth century the position of Secretary was the equivalent to our CEO.
4. S. Roberts, *Distant Writing: A History of the Telegraph Companies in Britain between 1838 and 1868* (2006), p.108, <http://tinyurl.com/z6syctd> (consulted 11 September 2016).
5. S. Roberts, *Distant Writing...* (2006), <http://tinyurl.com/jk4fmj8> (consulted 11 September 2016).
6. W. Feldenkirchen, *Werner von Siemens: Inventor and International Entrepreneur* (Columbus Ohio: The Ohio State University Press, 1994), p. 46.
7. J. S. Gamble, 'Gutta Percha Trees of the Malay Peninsula', *Bulletin of Miscellaneous Information, Royal Gardens, Kew*, vol. 4 (1907), pp.113-114.
8. J. Tully, 'A Victorian Ecological Disaster: Imperialism, the Telegraph, and Gutta-Percha', *Journal of World History*, vol. 20, no. 4 (2009), p. 575.
9. *Ibid.*, p. 571.
10. J. Collins, *Report on the Gutta Percha of Commerce* (London: George Allen, 1878).
11. E. Sérullas, 'On Gutta Percha', *India Rubber Journal*, vol. 7, no. 6 (1891), p. 162.
12. At the time the Spanish Dollar was the most widely accepted coinage in the region. It remained so until the introduction of the British Trade Dollar in 1895.
13. C. B. Buckley, *An Anecdotal History of Old Times in Singapore* (Singapore: Fraser & Neave, 1902), pp. 405-406.
14. Sérullas, 'On Gutta Percha' (1891), p. 163.
15. *Ibid.*
16. *Ibid.*
17. Oxley, 'Gutta Percha' (1847), p. 24.
18. Collins, *Report* (1878).
19. W. T. Brannt, *India Rubber, Gutta Percha and Balata* (London: Sampson Low, Marston, 1900), pp. 233-235.
20. Seligman-Lui et al, 'Le gutta-percha au point de vue de la telegraphie sous-marine', *Traite de telegraphie sous-marine* (1888), pp. 69-70.
21. H. L. Terry, *India Rubber and Its Manufacture, with Chapters on Gutta-Percha and Balata* (London: Archibald Constable & Co., 1907), p. 272.
22. Royal Botanic Gardens, Kew, 'Rediscovery of gutta percha tree at Singapore', *Bulletin of Miscellaneous Information CCXIII*, vol. 57 (1891), p. 231.
23. Royal Botanic Gardens, Kew, 'A List of Economic Plants Native or Suitable for Cultivation in the British Empire', *Bulletin of Miscellaneous Information*, vol. 7, no. 8 (1917), p. 263.
24. Royal Botanic Gardens, Kew, 'Indian Gutta Percha', *Bulletin of Miscellaneous Information CCLXXXIV*, vol. 72 (1892), pp. 296-7.
25. Royal Botanic Gardens, Kew, 'Rediscovery of gutta percha tree at Singapore', *Bulletin of Miscellaneous Information CCXIII*, vol. 57 (1891), p. 230.
26. Terry, *India Rubber* (1907), p. 273.
27. Tully, 'Ecological Disaster' (2009), p. 578.
28. Anon., 'Notes on Gutta Percha', *The Engineer* (6 May 1898), p.417.
29. T. Christy, 'A New Material', *India Rubber Journal*, vol. 5, no. 2 (1891), p. 107.
30. P. Taylor, 'Artificial Gutta Percha', *India Rubber Journal*, vol. 6, no. 10 (1890), p. 260.
31. D. Headrick, 'Gutta-percha: A Case of Resource Depletion and International Rivalry', *IEEE Technology and Society Magazine* (1987).



CATALOGUE ENTRY R1 | RESISTANCE

WILLIAM LIONEL WYLLIE (1851 – 1931)

# SCENE ON THE LOWER THAMES, 1884

46 X 81 cm

GUILDHALL ART GALLERY, CITY OF LONDON CORPORATION



William Lionel Wyllie was recognized as the leading British marine artist of the late nineteenth century: as one reviewer put it in 1905, ‘Mr. Wyllie has...for many years been the leading painter of the lower reaches of the river. He has, indeed, almost reduced them to a symbol’.<sup>1</sup> Wyllie’s interest was in the lower Thames estuary where the river runs out of the metropolis and towards the sea. This was the switch point where ships heading out to sea encountered those heading back into the Port of London. Wyllie is interested in the congestion of the working river with its ‘vessels of all sizes, of every form and character, from every seaport of the globe’.<sup>2</sup> By the mid nineteenth-century the Thames was alive and bristling with boats, as one contemporary observer recorded: ‘the river is crowded with shipping and steamers, and ...[ā] succession of vessels which affords the voyager so grand an idea of the vast trade of the British metropolis...Here are ... the ships that bear “to and fro” the wealth of every civilized nation and people’.<sup>3</sup> Wyllie’s first popular success was *Toil, Glitter, Grime and Wealth on the Flowing Tide* (1883), and this exhibition also includes his *Commerce and Sea Power* (1898) [cat. no. D2].<sup>4</sup> His interest in commerce and empire transform his seascapes into history paintings that record the agency of the sea in the industrialization of Britain.

Wyllie’s father was the coastal and maritime painter William Morrison Wyllie and he was encouraged to sketch and paint from early childhood. He studied at the Heatherley School of Fine Art and then the Royal Academy Schools, where he won the Turner Medal in his final year. Walter Sickert remarked on his considerable financial success, that ‘[n]oone ever thought of forming a society to protect the interests of a painter who understands the sea and shipping as does W.L. Wyllie’.<sup>5</sup> Wyllie studied the history of shipbuilding

to help him with his painting, and all his life he was an enthusiastic sailor of yachts and of his barge, *Ladybird*. He was greatly admired for his technical skill in painting: '[Mr. Wyllie] ...is in some sort master of the contrasts and conflicts between surface waves and the under-strength of the invincible ocean roll; and he can draw with singular skill a certain heavy, lumpy, storm-wave'.<sup>6</sup> Wyllie's pictures do not etherealize the sea, but rather render it fully material, with its traffic, its smoke and its 'lumpy' waves. His compositions are often concentrated around 'lumps' of congestion on the river. In this *Scene* we see flat low barges being pulled by tugs alongside huge ocean-going ships being steered back into port. The perspective of the painting suggests the funneling of vessels into the city and the sense of difficulty in pushing through the dense water traffic suggests the problem of pushing a force through a resistant medium. This river is less an open channel of communication than a dense succession of material obstructions and potential delays.

Wyllie's scrupulous attention to detail was important to his commercial success and later in his career he established an official connection with the Royal Navy, moved to Portsmouth, and became the Marine Painter to the Royal Yacht Squadron and the Royal Victoria Yacht Club. Alert to the commercial possibilities for artists opened up by the new transport and tourist routes, he worked for many years as an illustrator for the Graphic and also designed advertising posters for the big passenger ship companies, including the Orient Company and the White Star Line. He published illustrated books with his wife, Marian, and he was early in taking up the new technologies of colour printing to make his work better known.

CP

1. E.V. Lucas, 'From France to the Thames', *The Speaker: The Liberal Review*, (29 July 1905), p. 420.

2. Mr & Mrs S. C. Hall, *The Book of the Thames, From its Rise to its Fall*, (London: Arthur Hall, Virtue, and Co., 1859), p.469. Quoted in Professor John House, 'Monet: The River of Dreams' Gresham College Lecture, Museum of London, (15 March 2010). Transcript at: <http://tinyurl.com/hfvcvj> (consulted 26th August 2016).

3. Mr & Mrs S. C. Hall, *The Book of the Thames* (1859), p.469.

4. *Toil, Glitter, Grime and Wealth on the Flowing Tide* (1883) can be viewed at: <http://tinyurl.com/juttqeo> (consulted 26th August 2016).

5. Walter Sickert, Walter Sickert: *The Complete Writings on Art*, ed. by Anna Gruetzner Robins (Oxford: Oxford University Press, 2000), p.324.

6. Harry V. Barnett, 'By River and Sea', *Magazine of Art*, (January 1884), p.314.

CATALOGUE ENTRY R2 | RESISTANCE

EDWIN LANDSEER (1802–1873)

# MAN PROPOSES, GOD DISPOSES, 1864

91.4 X 243.7 cm

ROYAL HOLLOWAY, UNIVERSITY OF LONDON



Landseer's picture was painted in response to the ill-fated 1845 Franklin Expedition to the Canadian Arctic. The ice floes have wrecked the British ship and, '[t]wo hungry bears have come upon the relics of the expedition – a mast, a sail, a telescope. And a flag. One of the savage bears tears the red union jack, the other crunches the ribs of an unfortunate navigator'.<sup>1</sup> By the time he exhibited this picture, Landseer was famous as a painter of animals. He took great pains for this picture, studying polar bears from life at the Regent's Park Zoo in London. His depiction of the eerie reflections and colours in Arctic ice and the sense of the fragility of the wooden ship in this vast and remote landscape made the picture the, 'first for popularity...[t]he foremost picture of all' when it was exhibited at the Royal Academy in 1864.<sup>2</sup> But Landseer's choice of subject was also considered shocking by many.

The renowned explorer, Sir John Franklin, had led two ships and 129 men in 1845 to chart the Northwest Passage in the Canadian Arctic. But the expedition was to end in disaster. In 1854 news finally reached England of the grisly fates of the explorers who had left their ice-bound ships in search of food and starved to death. The native Inuit people reported that the final survivors had eaten their dead colleagues in an attempt to stay alive, even boiling down their bones for marrow. Remains found in the kettles suggested that this could have been true, and recent scientific analysis has since proved it beyond doubt. But in the nineteenth century the rumours of cannibalism were fiercely repressed. Perhaps one of the reasons that Landseer's picture created such a stir when it was first exhibited was because it obliquely invoked this spectre of cannibalism, by its use of the colour red, recalling spilt blood on the ice, and the two masticating bears, one 'crunching a blanched bone'.<sup>3</sup> The critics relished the goriness of the image, describing 'the frozen breath of the beast that crunches up a bleached bone as he sniffs the air with nose turned up in

an ecstasy of brutish relish'.<sup>4</sup> Some of their graphic descriptions even seemed designed to call to mind the possibility of cannibalism that they could not mention directly: 'Sir Edwin goes to the heart of the subject – animal life, ferocity and desolation. The ice even refuses a grave to those who braved its terrors, they are to have a living tomb in the maw of the wild beasts'.<sup>5</sup>

The failure of the Franklin Expedition and subsequent further discoveries of its remains in the 1850s and 1860s were being reported alongside the press reports of the attempts to lay the transatlantic submarine cable so that stories of remote communication and the battle with immense natural forces were vivid in the public imagination at this time. One critic remarked that *Man Proposes, God Disposes* 'pictured the utmost that Nature can do against human life and enterprise'.<sup>6</sup> The picture's title focuses on the hubristic nature of Franklin's attempt to establish a communications route to East Asia between the Atlantic and Pacific Oceans, but also on the grandeur of the ambition. Landseer became increasingly mentally ill throughout his middle age and his painting has been read as becoming correspondingly pessimistic.<sup>7</sup> However this painting suggests an ambivalence about the natural environment widely shared by scientists and artists in the Victorian period. They celebrated the human ability to master nature and to build technology that 'annihilated' distance, but at the same time, increased understanding of the physics of the universe called out a new awe and wonder at its complex and resistant materiality.

CP

1. 'The Royal Academy', *Art Journal* (June 1864), p. 168.

2. W. M. Rossetti, 'Art Exhibitions in London', *The Fine Arts Quarterly Review* (October 1864), p. 22.

3. 'Exhibition Of The Royal Academy', *The Times* (30 April 1864), p. 14.

4. 'The Royal Academy', *London Review of Politics, Society, Literature, Art, and Science* (7 May 1864), p. 487.

5. 'Exhibition Of The Royal Academy', *The Times* (30 April 1864), p. 14.

6. 'The Royal Academy', *London Review* (1864), p. 487.

7. See Richard Ormond, Joseph J. Rishel and Robin Hamlyn, *Sir Edwin Henry Landseer*, exh. cat. (Philadelphia Museum of Art and Tate Gallery, London: 1982).

CATALOGUE ENTRY R3 | RESISTANCE

JOHN LINNELL (1792 – 1882)

## THE TIMBER WAGGON, 1872

103 X 132 cm

GUILDHALL ART GALLERY, CITY OF LONDON CORPORATION



The tree trunks that the workers are heaving onto the wagon are huge, mature and valuable hardwood, probably destined to be used for ship or house building. Despite the figures who look on from the sidelines, including a baby and a dog, the landscape is not one of ease and visibility, but rather a knotted, closely detailed, intricately-patterned environment which is resistant to passive looking and both forces our attention and disperses the viewers' eye uncomfortably across the canvas. In nature, Linnell was said to find, 'a brooding and indwelling presence, some of whose moods might, from time to time, be transferred to canvas'.<sup>1</sup> His insistence on the thick detail of the natural environment springs from his intense, almost visionary, religious belief in the visibility of God in the world. He shared this with his friend William Blake and his son-in-law the artist, Samuel Palmer. The emphasis on the difficulty of the labour of loading and the upcoming difficulty of moving the laden wagon, even with three sturdy horses, insists on the struggle of forging a path and deciphering the meaning of the natural world. The difficulty is reflected in a landscape which is resistant – the clouds which press down on the earth seem as thick and substantial as the brushy undergrowth and the wind-distorted hawthorn bushes. The dirt road is dusty, rutted and stony, and the roots of trees and bushes threaten to snag and delay progress. The strange stylization of Linnell's landscapes was noticed in his lifetime: 'that remarkable quality of Linnell's Art, which, for lack of a better term, I have called his style – a term not commonly applied to design in landscape, but distinctly

apt to the mode of Linnell'.<sup>2</sup> Linnell once remarked that 'painters generally represented the sky as flat, whereas, being concave, and the clouds floating beneath it, they ought to project and show the effects of light on all sides of them...hence arose the sculpturesque fidelity with which he was enabled to depict the scenery of cloud-land'.<sup>3</sup> That he 'sculpts' his clouds as much as his carts makes for this thick, resistant, encroaching landscape of tactile materiality through which the small human figures have to push themselves while constantly running the danger of being tripped, scratched and grazed.

This painting, which Linnell painted when he was eighty years old, recalls his earlier and very successful 'elaborately composed' canvas, *The Timber Waggon* of 1852, which was exhibited at the Royal Academy (no. 456), and the *Exposition Universelle* in Paris in 1853.<sup>4</sup> Linnell made several copies of this first painting and then returned to a similar subject in 1871 and 1872, producing two more differently composed paintings of the same name.<sup>5</sup>

Linnell was never elected to the Royal Academy even though, 'he kept his name among those of the candidates for election for more than thirty years'.<sup>6</sup> The son of an artisan carver and guildier in Bloomsbury, he worked as a jobbing portrait painter and engraver until his landscape paintings gained recognition and sales when he was in his fifties. Late in his life he was asked to stand again for the Academy, but he declined the offer.

CP

1. 'Review of Alfred Story, *The Life of John Linnell*, *Athenaeum* (17 December 1892), p.860.

2. F.G. Stephens, 'The Aims, Studies, and Progress of John Linnell, Painter and Engraver', *Art Journal* (February 1883), p.37.

3. Alfred T. Story, 'John Linnell's Country', *Art Journal* (October 1892), p.305.

4. *Ibid.*, p.304.

5. Information on 1852, 1871 and 1872 versions of *The Timber Waggon* in Appendix to A. Story, *The Life of John Linnell* (London: Bentley and Son, 1892). Available online at <http://tinyurl.com/jauk8f5> (consulted 26th August 2016). See also Evan Richard Firestone, 'John Linnell, English Artists: Works, Patrons and Dealers', PhD thesis (University of Wisconsin, 1971), p. 167.

6. 'Review of Alfred Story, *The Life of John Linnell*' (1892), p.861.

CATALOGUE ENTRY R4 | RESISTANCE

JOHN MOGFORD (1821 – 1885)

# RIVER SCENE, BEFORE 1885

66 X 97 cm

GUILDHALL ART GALLERY, CITY OF LONDON CORPORATION



*River Scene* is a picture about blockage, stagnation and resistance. Its confusing topography makes it unclear where the path over the bridge is leading, although it is clear that it has caved in and collapsed just ahead of the heavily-laden donkey. The seeming direction of the path conflicts awkwardly with the lines of the landscape and hills, and the ‘river’ of the title does not flow but sits in a stagnant pool dammed by a sluice gate. Although the peasant woman and donkey could belong to a pleasantly pastoral scene, this picture is telling us something rather different about the Cornish landscape. A clue is in the clotted red deposit that seems to float on the water’s surface, lending it an unhealthy silted-up quality. It seems likely that this water pollution is a result of the Cornish metal mining industry that had reached its peak in the late eighteenth and early nineteenth centuries.<sup>1</sup> Copper and tin were mined all over Cornwall and exported all over the world. By the late nineteenth century, when it is likely that this picture was painted, the Cornish mining industry was in decline and ‘[i]n the first 6 months of 1875 over 10,000 miners left Cornwall to find work overseas.’<sup>2</sup> Global competition and cheaper extraction of mineral resources elsewhere in the world made the Cornish mines uneconomic.

Mogford’s picture, therefore, is not about the power of industry and commerce as are, for example, Wyllie’s depictions of the busy Thames. Mogford paints instead the residue of industry, both literally floating in the pooled ‘river’, and metaphorically, in the poverty and ruination of infrastructure: the sluice gate is decrepit and crumbling, its levers rusted

and its wood bleached, and the road is in a perilously neglected state.<sup>3</sup> The composition has a striking resemblance to twenty-first-century photographic views of the desolate and strangely coloured landscapes resulting from metal mining in Portugal.<sup>4</sup> The picture might be quietly suggesting that Free Trade Liberalism and the opening up of Empire by ship and telegraph creates global competition which can have unforeseen consequences for local economies.

With the appearance of the telegraph and new electrical technologies in the second half of the nineteenth century, the demand for copper accelerated as it is a highly effective electrical conductor. This incentivized the discovery of larger deposits of copper ore in Chile and Peru and the price of copper consequently decreased. Despite the fact that Porthcurno Bay in Cornwall was the landing point for the 1870 underwater cable to Bombay (Mumbai) in India and the site of an important Imperial training college for telegraphy engineers, Cornwall was losing its copper industry.<sup>5</sup>

Mogford shows us the effects on the local of the global. The peasant woman walking slowly with her donkey seems a long way from the state-of-the-art telegraph cabling in operation at this time, but Mogford shows us that the two are in fact connected.

Although he lived in London, Mogford became a regular visitor to Cornwall from 1862 and, between then and his death in 1885, he regularly exhibited both oils and watercolours of Cornish subjects.

Mogford was born in London but his family's background was in Devon. He studied at the Somerset House Government School of Design, and went on to exhibit at the Royal Academy, British Institution and Suffolk Street Gallery. He lived in Hampstead, and became a member of the Institute of Painters in Watercolours. As a day job, he taught at the Maddox Street art school, where his pupils included Emily Mary Osborn, one of the most important artists associated with the campaign for women's rights in the nineteenth century.<sup>6</sup>

CP

1. The plot of the hugely successful BBC remake of the *Poldark* series pivots around Cornish mining in the late eighteenth century. Series One was broadcast in March and April 2015.

2. <http://tinyurl.com/jcedchk> (consulted 8 September 2016).

3. It is unclear from the internal evidence of the picture whether this is really a 'river'. I have been unable to establish whether Mogford named the painting himself or whether it was given this generic name by dealers. It seems that what may be depicted is an industrial sluice, or

a purpose-built sump where mining effluvia was dumped.

4. For example a photograph by Gustavo Veríssimo from Setúbal, Portugal - lagoa vermelha, <http://tinyurl.com/j9yzb89> (consulted 8 September 2016).

5. For further information and archive images, see the Porthcurno Museum site: <http://telegraphmuseum.org> (consulted 8 September 2016).

6. For more information on Emily Mary Osborn, see the Tate Gallery website: <http://tinyurl.com/hqawpja> (consulted 8 September 2016).



CATALOGUE ENTRY R5 | RESISTANCE

PETER GRAHAM (1836 – 1921)

# *RIBBED AND PALED BY ROCKS UNSCALABLE AND ROARING WATERS, 1885*

158 X 133 cm

GUILDHALL ART GALLERY, CITY OF LONDON CORPORATION



Graham's paintings emphasized the sublime scale of the landscapes they depicted, as critics at the time noticed, '[t]he majestic cliff scenery ... [has] an overwhelming effect of size and height. The grim face of sheer perpendicular rock, rising straight from the ocean's bed, almost made one shudder to look upon - so forbidding, so awful was it in

its stern supremacy'.<sup>1</sup> *Ribbed and Paled by Rocks Unscalable and Roaring Waters* is a large canvas that takes its title from Shakespeare's late play, *Cymbeline*. In the play, the English King, Cymbeline, is encouraged by his Queen to break from the Roman Empire and assert England's independence. She asserts the coastal and maritime geography of the British Isles as a defence in itself, recalling Caesar's struggle for a 'kind of conquest' when Britain was invaded by Romans:

...his shipping--  
 Poor ignorant baubles!-- upon our terrible seas,  
 Like egg-shells moved upon their surges, crack'd  
 As easily 'gainst our rocks (*Cymbeline*, Act 3, Scene 1)

Graham's picture shows the power of the sea with its treacherous broiling waves and the obdurate granite rocks that prevent access or landing to all but the sea birds who calmly inhabit them. Its double perspective, which shows us the water roaring at the foot of the rocks as well as the tall rock face, is closer to that of a bird in flight than to a human observer. This is a picture of untrammelled nature able to 'crack' boats against her rocks and obliterate the human. Rocks and rough seas made laying submarine cables risky and difficult. On the second attempt to lay the transatlantic cable in 1858, the British cable-ship, the *Agamemnon*, nearly went down in a violent storm. The coil of cable stored in the main hold, 'had begun to get adrift...till some forty or fifty miles were in a hopeless state of tangle, resembling nothing so much as a cargo of live eels, and there was every prospect of the tangle spreading deeper and deeper as the bad weather continued'.<sup>2</sup> The fight with the elements and the ocean was an important part of the ongoing cable-laying drama and Graham's painting reminds us of the immensity of scale of the marine aspect of the undertaking.

By the time of Peter Graham's death in the early twentieth century, his rugged Scottish landscape paintings had fallen out of fashion. The new movements of Impressionism, Post-Impressionism, Cubism, and Futurism made Graham's canvases of Scottish landscapes seem old-fashioned and dull. One of his friends wrote that, '[i]t is the fashion to-day to deride 'Eminent Victorians' and their works. Peter Graham's cattle ... have become a jest'.<sup>3</sup> Charles Lewis Hind wrote that by the 1880s, '[f]ew critics troubled themselves to say anything about Peter Graham's pictures of shaggy Highland cattle, in rough Scots weather, with the mist swirling up over the desolate hills. There was nothing to say about them. One picture was like another. Year after year he showed these same shaggy Highland cattle in the same "nasty" Scottish weather'.<sup>4</sup> There was already a certain weariness in the reports of Graham's works in exhibitions in the 1880s and 1890s: 'Mr. Peter Graham, another sea birds' haunt', and, 'Mr. Peter Graham has two very woolly pictures...harsh and crude in colour, and like so many other works by the Academicians, far below the mark'.<sup>5</sup>

But Peter Graham had once been credited with bringing landscape painting back into the repertoire of the Royal Academy. In 1866 he exhibited *A Spate in the Highlands* there and ‘created much excitement’.<sup>6</sup> His paintings sold for high sums and were greatly admired for their unwavering fidelity to the Scottish coast and highlands, ‘[h]e will transport you to some rocky headland where you will feel the salt spray in your face, you will hear the call of the gulls as they sweep the waves, and watch the storm gather in the West’.<sup>7</sup> Born in Edinburgh and trained at the Edinburgh School of Art, Graham, ‘brought home to the toilers in the cities aspects of the Highlands which had never before been depicted in paint, and with which the vast majority of people of this country were unfamiliar’.<sup>8</sup>

CP

1. This is a description of Graham’s 1872 painting, *The Cradle of the Sea-Bird*. W.W. Fenn, ‘Our Living Artists: Peter Graham’, *Magazine of Art* (January 1879): p. 146.

2. ‘Laying the Atlantic Telegraph Cable’, *Illustrated London News* (31 July 1858), p. 111. On this second attempt, the worst storm the expedition encountered was on 20 and 21 June and the *Agamemnon* nearly went down.

3. Margaret Sparrow, ‘The Pictures of Peter Graham’, *Saturday Review* (5 November 1921), p. 532.

4. Charles Lewis Hind, *Landscape Painting, from Giotto to the Present Day*, 2 vols, (New York: C. Scribner’s Sons, 1924), vol. 2, p.121.

5. ‘Art in March’, *Magazine of Art* (January 1885): p. [xxi]; ‘The Picture Galleries-IV’, *Saturday Review* 57 (31 May 1884), p.713.

6. W.W. Fenn, ‘Our Living Artists: Peter Graham’, *Magazine of Art* (January 1879): p.144. *A Spate in the Highlands* (1866, Manchester Art Gallery) can be viewed at: <http://artuk.org/discover/artworks/a-spate-in-the-highlands-205094>

7. Sparrow, ‘The Pictures of Peter Graham’ (1921), p. 533.

8. W. Matthews Gilbert, *The Life and Work of Peter Graham*, R.A. (London: The Art Journal Office 1899) / *Art Annual* 1899, p. 24.

CATALOGUE ENTRY R6 | RESISTANCE

THOMAS HOPE MCLACHLAN (1845 – 1897)

## THE ISLES OF THE SEA, 1894

71 X 127 cm

GUILDHALL ART GALLERY, CITY OF LONDON CORPORATION



The title of McLachlan's canvas makes us wonder about the difference between land and water because the sea is painted to look as substantial as the rocks. The waves seem clotted and heavy, creating a substantial mass that looks difficult to traverse or travel through. The 'charm and subtlety of Mr. McLachlan's colour and tone' was noticed by critics at the time, along with his 'fondness for and power of depicting large spaces of sky, especially when heavy masses of cloud move swiftly across ... Mr. McLachlan also has the gift (it is no very common one) of conveying to us a sense of solidity, of actual physical weight'.<sup>1</sup> Like other paintings in the 'Resistance' section of the exhibition, McLachlan's investigate the materiality of the physical world and ways in which its solidity both invites and impedes human passage. But McLachlan's paintings are also marked by a greater abstraction than others in this section. While his paintings show the influence of the Pre-Raphaelites, particularly Dante Gabriel Rossetti, and of the Barbizon painters, including Jean-François Millet, he is more involved with colour, form and light at an abstract level than these painters.

'Above all things, he had design', announced one critic. McLachlan's later work was innovative in the way it moved away from 'realist' narrative.<sup>2</sup> Only a few critics discerned the novelty and originality of the landscapes that were 'skied' at the Royal Academy shows and appreciated McLachlan's ability to paint 'a picture which tells no story, a very quiet picture in its motive, colour, tone'.<sup>3</sup> These critics recognized McLachlan's intense, meditative inhabitation of his landscapes and seascapes: '[w]e see it in such a piece as "Ships that Pass in the Night", where the intensity of the starry sky seen between the breaks of the drifting clouds and the depth of tone in the purple sea are rendered not only with

truth, but with a sense of profundity and mystery which lifts the picture into the region of the imagination'.<sup>4</sup> Similarly, in *Isles of the Sea* McLachlan produces a mythologized almost magical landscape. The intense blues and yellows make us see the sea anew, not as a 'seascape' but as a strange viscous substance in motion under its own laws. The direction and motion of the water around the rocks suggests the treacherous depths below. In the 'gigantic undertaking' of laying the transatlantic cable, telegraph engineers conducted exhaustive depth soundings to establish the best route for the cable, avoiding rocks and reefs. They were surprised to discover what they called 'The Telegraph Plateau'. This was 'a great flat or level at the bottom of the ocean, unparalleled by anything on the surface of the earth ... it appears as if nature had provided a bed "soft as a snowbank", ... for the express purpose of receiving a telegraphic cable'.<sup>5</sup> In reality, it proved much more difficult to lay the cable than such providential language suggested.

McLachlan would probably be much better known today if he had not died young, suddenly and unexpectedly when he was only 52 years old. He was born in Darlington and educated at Merchiston Castle School, Edinburgh and then Trinity College Cambridge, where he came first in the Moral Science Tripos. He came to London and entered as a law student at Lincoln's Inn, was called to the Bar and practiced at Court of Chancery for some years before leaving the law to devote himself to painting.<sup>6</sup> In the 1890s, McLachlan's work was favourably compared to that of Peter Graham, as Graham was seen to be 'monotonously repeating his familiar Highland cattle and mountain scenery'. We can compare the styles of the two painters in this section of the exhibition.<sup>7</sup>

CP

1. Selwyn Image, 'Thomas Hope McLachlan', *The Magazine of Art* (January 1895), p. 57 and p. 62.
2. Herbert P. Horne, 'Thomas Hope McLachlan', *Saturday Review* (12 June 1897), p. 656.
3. Image, 'McLachlan' (1897), p. 57. Herbert P. Horne describes how McLachlan's canvases were 'skied' at the Academy exhibitions and Stanley Jas regretted that the 'lispering senilities' of the Royal Academy 'gave him scant encouragement during his lifetime', Horne, 'McLachlan' (1897), p. 655. Stanley Jas, 'The Art Exhibitions and their Lessons', *New Century Review* (June 1897), p. 442 and p. 452.
4. Horne, 'McLachlan' (1897), p. 656.
5. 'The Recent Soundings for the Atlantic Telegraph', *Illustrated London News* (13 September 1856), p. 267.
6. Information from Horne, 'McLachlan' (1897), p. 656.
7. Jas, 'The Art Exhibitions' (1897), p. 450.

CATALOGUE ENTRY R7 | RESISTANCE

# CHARLES WHEATSTONE'S WHEATSTONE BRIDGE

KING'S COLLEGE LONDON ARCHIVES. K/PP107/11/2/1



Of the many inventions that bear Charles Wheatstone's name, the Wheatstone Bridge is perhaps the best known. This is slightly ironic as it was in fact not devised by Wheatstone himself but by Samuel Hunter Christie.

Christie was interested in how the electrical and magnetic properties of a metal varied with mass and dimensions. He constructed a circuit to allow him to measure the electrical resistance (though he called it Magneto-electric induction) of wires of different thicknesses. In the 1833 lecture to the Royal Society in which he displayed the circuit, he called it the Diamond method, referring to the shape made by the wires.<sup>1</sup>

The diamond can be imagined as having two parts, the uppermost two wires (called 'legs') comprising one part, the lower two 'legs' the other. Across the middle of the circuit, joining these two parts is a bridging wire into which a galvanometer is connected. Galvanometers detect the flow of electricity. If the top part and the bottom part of the circuit are balanced (i.e. they have the same resistance) then no electricity will flow across the bridging wire and the galvanometer will stay at zero. If the two halves are unbalanced - if one part has a higher resistance than the other - then electricity will flow across the bridge and

be detected by the galvanometer. Importantly, if you know the resistance of three of the 'legs' you can work out the resistance in an unknown fourth one.

The Diamond method - though an interesting experiment - languished as a footnote in a paper about magnetism for ten years until 1843, when Charles Wheatstone (with his usual inventive pragmatism) saw the potential in it. In a lecture he delivered at the Royal Society (in which he fully cited Christie as the originator of the circuit) Wheatstone outlined several applications.<sup>2</sup> First, you could connect up far more useful things to the 'unknown' leg of the circuit than different bits of copper wire. You could connect it up to telegraph lines, submarine cables, electrical circuits, even entire telegraphic instruments and measure their resistance. This observation meant that, for the first time, telegraph engineers had a way to measure the electrical efficiency of their designs; an insight into how to hone and perfect their materials and apparatus. They could see the effect of impurities on the conductivity of copper wires, the extra capacitance effects of a thick insulation, or the resistance of a particular design of switch.

Moreover, it was suddenly possible to see the effects of other forces on telegraph equipment. For example, the same piece of cable could be tested at different temperatures or pressures to gauge the effect of the environment on it. The most important realisation - and perhaps the factor which best explains why it is Wheatstone who is remembered for his Bridge rather than Christie for his Diamond - Wheatstone pointed out that the galvanometer is not just as an instrument for measuring resistance. It can be used to measure any number of things including inductance, capacitance, impedance and frequency (including radio frequency). Wheatstone's observations led others to modify the Bridge and push it to new heights of usefulness. Indeed, William Thomson, gave his name to a modified form of the bridge, the Kelvin Bridge, which when hooked up to the incredibly sensitive mirror galvanometer, allowed him to continually monitor the electrical condition of the 1865 and 1866 Atlantic cables.<sup>3</sup>

CN

1. S. H. Christie, 'Bakerian Lecture: Experimental Determination of the laws of Magneto-electric Induction in different masses of the same metal, and its intensity in different metals', *Philosophical Transactions of the Royal Society of London*, vol. 123 (1833).

2. C. Wheatstone, 'Bakerian Lecture: An Account of Several New Instruments and Processes for Determining the Constant of a Voltaic circuit', *Philosophical Transactions of the Royal Society of London*, vol. 133 (1843).

3. M. Trainer, 'The Patents of William Thomson Lord Kelvin', *World Patent Information*, vol. 26, (Elsevier Ltd, 2004), <http://tinyurl.com/hv4c2lk> (consulted 4 September 2016).

CATALOGUE ENTRY R8 | RESISTANCE

# RESISTANCE BOX

KING'S COLLEGE LONDON ARCHIVES. K/PP107/11/1/19



The resistance box is an interesting object. It is interesting because, unlike its more famous lab-bench counterparts (for example, the Daniell cell or galvanometer), very little is known about its origins or originator. Wheatstone is certainly using a 'variable resistor' to control the known but variable 'leg' of his Wheatstone bridge in 1843, though we don't know what this looked like.<sup>1</sup> The 'variable resistor' appears again in Kelvin's 1858 patent drawing for the marine galvanometer but as a set of spools in an open box.<sup>2</sup> Neither appear to have been as sophisticated as the box in the exhibition. We can, however, use what we know about the box to determine its probable use.

It is built solidly from well-used light oak. A deep, hinged lid reveals a brass plate set across the top half of the upper surface. The plate is split into eight rectangles. The outer two rectangles sport positive and negative terminal screws respectively. Each of the six inner rectangles is separated from the next by a gap of a few millimetres with a round hole in the centre, in which sits a brass peg.

Inside the box beneath the holes are hand-wound resistors. Wire (probably of German Silver, 60% copper, 25% zinc, 15% nickel) of an exact length and mass is wrapped around



a ceramic bobbin to give a known resistance.<sup>3</sup> Each of the resistors is connected to the next by a thin wire. When a peg is inserted into the hole above, it short-circuits the small connecting wire, and removes that resistor from the circuit. The idea of the instrument is that a piece of electrical equipment can be connected to the outer terminals and the pegs placed in the mileage holes to create any electrical resistance. In the lower, wooden half of the surface there are six holes in the wood to receive any unused pegs.

Resistance boxes were used for many different kinds of lab work as well as for activities of electrical and telegraphic engineers, however the construction of the box gives us some clues to its purpose and origin. The brass rectangles are marked 1, 2, 4, 8, 16 and 32 miles respectively, meaning that its purpose is to create resistances in miles rather than ohms. This suggests an application in telegraphy, rather than bench-based lab work. Submarine telegraphy is ruled out as a maximum of 63 miles resistance would be insufficient for most submarine systems. Certain possibilities are suggested.

The box could have been used to replicate 'real' conditions for the testing of prototype telegraphic equipment in the lab. Or it could be used to balance the resistance on the 'dummy' circuit used in Duplex telegraphy (where messages can be sent in both directions on a line simultaneously). However, the rugged, portable design (and well-used condition of the box) suggests it was carried around from place to place by engineers who needed to know about (a fairly limited number of) miles of resistance. In other words, fault finding.

When a line has a fault, engineers carry out a resistance check. The terminals of the resistance box are connected up to the variable resistance leg of a Wheatstone bridge. The faulty line is then connected up to the 'unknown' leg of the bridge. Pegs are placed in the holes of the resistance box until the resistance of the faulty wire and the resistance of the pegs are equal. Engineers can then be dispatched to the number of miles down the line as indicated by the resistance box and the fault repaired.

CN

1. C. Wheatstone, 'Bakerian Lecture: An Account of Several New Instruments and Processes for Determining the Constant of a Voltaic circuit', *Philosophical Transactions of the Royal Society of London*, vol. 133 (1843).

2. M. Trainer, 'The Patents of William Thomson Lord Kelvin', *World Patent Information*, vol. 26 (2004), <http://documentslide.com/download/link/the-patents-of-william-thomson-lord-kelvin> (accessed 22/08/2016).

3. Anon., *Laboratory Instruments and Measurements: Book 14* (New York: The Electrical Engineer Institute of Correspondence, 1904).

